

F3300[®]
3D Printing System



Copyright

Copyright © 2024 - 2026 Stratasys Ltd. All rights reserved.

No part of this document may be photocopied, reproduced, or translated into any human or computer language in any form, nor stored in a database or retrieval system, without prior permission in writing from Stratasys. This document may be printed for internal use only. All copies, shall contain a full copy of this copyright notice.

Trademarks

Stratasys, F3300, GrabCAD, GrabCAD Print, Insight, and FDM are trademarks of Stratasys and/or subsidiaries or affiliates and may be registered in certain jurisdictions. All other product names and trademarks are the property of their respective owners.

ULTEM™, 9085, and 1010 are trademarks of SABIC, its affiliates or subsidiaries.

Liability

Stratasys shall not be liable for errors contained herein or for incidental or consequential damages in connection with the furnishing, performance, or use of this material. Stratasys makes no warranty of any kind with regard to this material, including, but not limited to, the implied warranties of merchantability and fitness for a particular purpose. It is the responsibility of the system owner/material buyer to determine that Stratasys material is safe, lawful, and technically suitable for the intended application as well as identify the proper disposal (or recycling) method consistent with local environmental regulations. Except as provided in Stratasys' standard conditions of sale, Stratasys shall not be responsible for any loss resulting from any use of its products described herein.

Disclaimer

Customer acknowledges the contents of this document and that Stratasys parts, materials, and supplies are subject to its standard terms and conditions, available on <http://www.stratasys.com/legal/terms-and-conditions-of-sale>, which are incorporated herein by reference.

The specifications and/or information on which this document is based are subject to change without notice.

Feedback

If you have any questions or comments about the way information is presented in this guide, or if you have any suggestions for future editions, send a message to c-support@stratasys.com.

www.stratasys.com

Revision History



Translations of this guide are updated periodically. If you are consuming a translated version, please check the English version for latest revision and list of updates.

Rev.	Release Date	Description of Changes
A	Aug. 2024	Initial release
B	Nov. 2024	<ul style="list-style-type: none">• Added ULTEM resin to ASA, Material Bay Drive Assembly and Upper Filament Tube procedures.• Added filament storage solutions• Updated Loading Material procedure• Updated PM Kit lists• Added Tool Base Cutter procedure
C	Apr 2025	Updated for software v3.6
D	Nov 2025	<ul style="list-style-type: none">• Updated for software v4.6• Updated fan orientation note in Extruder Drive Fan procedure• Updated Consumables tables and notes• Updated Service Level PM lists• Added Build Chamber Cameras procedure• Removed Tip Cal Shield procedure• Added MTConnect list
E	March 2026	<ul style="list-style-type: none">• Updated for software v4.13• Added Registration and Commissioning to Chapter 4• Updated screen shots and images in Chapter 5• Added Extruder Drive Motor procedure to Chapter 7• Updated MT Connect data in Chapter 8

Contents

1 About This Guide	1
Guide Objective	1
How to Use This Guide	1
Conventions Used in This Guide.....	1
Symbols and Notes	2
Service and Software Support.....	2
2 Introducing the 3D Printing System.....	3
Printer Overview	3
Features.....	4
Technical Characteristics	4
Environmental Requirements.....	5
Access Doors and Panels	6
Pneumatics Panel	13
Pneumatics Board	14
Oven Components.....	15
Z Stage	18
Gantry	20
X, Y, and Local Z Motion Components.....	20
Extruders, Tool Rack, and Local Z Assembly.....	23
Electronics Panels and Boards.....	26
Electronics Panel	26
Power Distribution Board.....	27
X,Y, and Local Z Dual Motor Amplifier Boards	28
Expansion Single Board Computer Board	29
Climate Control Board (Oven).....	30
Controller Board.....	30
Z Stage Dual Motor Amplifier Board	31
Climate Control Board (Dryer Bay)	32
Front Interface Board	33

Material Bay ID Boards	33
Filament Spool Interface Boards.....	34
Material Delivery.....	35
Material Bays	35
Material Spools	36
Filament Accumulators.....	37
Consumables.....	38
Software	42
Controller Software	42
GrabCAD Print Software.....	42
Insight Software	42
3 Safety	53
Safety Instructions	53
Product Safety Signs	53
Product Safety Label Locations	55
E-Stop	60
Potential Safety Hazard Areas	61
Oven	61
Gantry.....	61
Z Stage.....	61
Oven Door and Access Door Interlocks	62
General Safety Practices	62
Lockout Tagout (LOTO).....	62
Safe Environment	63
Safe Human Interface.....	63
4 Setting Up the Printer.....	64
Maintenance Tools and Preparation	64
Welcome Kit.....	64
Basic Setup	66

Stabilizing the Printer	66
Identifying Your Printer	68
LAN Requirements.....	69
Making the Network Connection	69
Compressed Air Connection	70
Electrical Service Connection	71
Registering and Commissioning the Printer.....	72
Installing the GrabCAD IoT Platform	73
CS Service Personnel.....	80
Configuring the Network	83
Network Address Configuration	83
GrabCAD Software	85
GrabCAD Print.....	85
GrabCAD Print Server.....	87
Viewing Printer Details.....	93
Creating Print Jobs Using GrabCAD Print.....	94
Data Sharing with Stratasys Using GrabCAD.....	99
GrabCAD and GDPR.....	99
Insight Software	100
FDM Control Center Software.....	101
Setting the Printer’s Date and Time (FDM Control Center).....	101
Setting the Printer’s Date and Time (GrabCAD Print).....	103
Updating the Controller Software Version	104
Adjusting the Tip Wipe Height.....	104
Stratasys Online Resources	104
Stratasys Academy	104
Stratasys Support Center.....	105
Stratasys Academy YouTube Channel.....	105
GrabCAD Community	106
5 User Interface.....	107
Overview.....	107
Navigation Menu	108

Display Area	108
Working with the Home Page	108
Loading a File	111
Viewing Print Job Information	114
Build Status Display	115
Idle	115
Building	116
Extruder Drive Light Display States	117
Print Job Controls	118
Play Button	119
Pause Button	121
Cancel Button	122
Working with the Queue Page	123
Adding a Job to the Job Queue	124
GrabCAD Print Method	124
USB Method	124
Editing the Job Queue	126
Job Queue Controls	127
Viewing Job Details	127
About the Sample Queue	128
Working with the Consumables Page	129
Viewing Hot End Details	130
Material Status Icons	131
Viewing Material Details	131
Material Load Controls	132
Platen Vacuum Control	133
Working with the Settings Menu	136
Settings Menu	137
Chamber Brightness	138
Version Numbers, System Odometer, and Open Source	139
Energy Saver	140

Units	141
Network Settings.....	141
Update Software.....	143
Build Settings.....	143
Connectivity Settings	144
Registration.....	145
Move Stage	145
6 Operating the Printer.....	146
Basic User Operations.....	146
Powering On the Printer.....	146
Powering Off the Printer.....	149
Installing the Extruder Assembly.....	151
Loading Material.....	153
Inserting a Spool into a Material Bay	153
Loading Material into the Tool	158
Unloading Material.....	163
Unload Material from the Tool	163
Retracting Material from the System and Removing a Spool	166
Handling/Storing Materials.....	168
Reuse Spool Packaging	169
OEM Dry Box Containers	171
OEM Dry Cabinets.....	172
Exchanging the Hot End Assembly	174
Basic Job Build Tasks.....	177
Before a Build	177
Installing a Build Sheet	178
Starting a Part.....	179
Optimizing Tool Order and Setting Up Redundancy	183
After a Build is Complete	187
Removing a Part from the Printer	188

Changing Material from ULTEM™ Resin to ASA.....	189
Changing from ASA to High Temperature Materials.....	190
Changing Printer Defaults	191
Software Version.....	191
7 Maintaining the Printer	196
Calibration and Adjustments	196
Automatic Tip Calibration	196
Tip Wipe Height Adjustment.....	196
Manual Nozzle Calibration	197
Updating Controller Software	203
GrabCAD Print Method	203
Control Center Software Method	206
Exporting System Configuration (*.CFG) File	208
GrabCAD Print Method	208
Insight Software Method	211
Maintenance Schedule	212
Weekly Maintenance	213
Cleaning the Oven Chamber	213
Cleaning the Platen.....	213
Monthly Maintenance	214
Clean/Inspect Tip Wipe Assemblies.....	214
As Needed Maintenance	217
Cleaning the Exterior Surface of the Printer	217
Cleaning the Touchscreen Display.....	217
Service Level Preventive Maintenance (PM).....	218
One Year PM Recommendations.....	218
Two Year PM Recommendations	219
Five Year PM Recommendations.....	219

Safety Verification	220
Customer Replaceable Units	221
Material Bay Drive Assembly	221
Filament Tubes - Upper	222
Extruder Drive Motor	225
Extruder Drive Fan	230
Build Chamber Cameras	232
8 Troubleshooting	236
Getting Help	236
Warnings and Errors	236
Obtaining a Diagnostic File	237
Errors Preventing a Build from Starting	237
Load/Unload Errors	237
Build Pause Warnings	238
Build Abort Errors	238
Finding a Remedy	239
Tool and Material Bay Jams	241
Recovering from a Failed Build	242
Recovering from a Power Failure or Build Freeze	242
Recovering from a Loss of Shop Air	242
Recovering from an E-stop Activation	242
Tool Maintenance	243
Tool Base Buttons	245
Tool Base Cutter	246
MTConnect	247
9 Regulatory and Environmental Information	249
Declaration of Conformity	249
Electromagnetic Compatibility (EMC)	249

Title

EMC Class A Warning	249
FCC Class A Statement (U.S.A.)	249
FCC Suppliers Declaration of Conformity:.....	250
Canada Electromagnetic Compatibility (EMC).....	250
Normes de Sécurité (Canada).....	250
DOC Statement (Canada)	250
Material Safety Data Sheets (MSDS)	250
Waste Electrical and Electronic Equipment Directive (WEEE) Symbol	251
UK Conformity Assessed (UKCA) Marking.....	251
Conformité Européenne (CE) Marking	251
GrabCAD and GDPR.....	251
Appendix A: Diagrams and Schematics	252

1 About This Guide

This chapter provides information regarding Stratasys contact information and helpful details for using this guide.

Guide Objective

This guide is your introduction to building prototypes and end-use parts using a Stratasys 3D production, rapid prototype system. It is designed as a learning and reference tool that explains system operation in an easy to understand, step-by-step, process.

How to Use This Guide

This guide is divided into easy-to-follow chapters. You can read this guide chapter by chapter or use the Table of Contents when you need to quickly find specific information. Keeping this guide close to your printer will efficiently allow you to troubleshoot and maintain the printer.





Conventions Used in This Guide

The following conventions are used in this guide:

- When you see text in **this font**, it indicates a button being pressed via the User Interface touchscreen. For example, press the **Queue** button within the Navigation Bar.
- When you see text in [blue](#), it indicates that the text is a linked reference to a specific figure, table, heading, or page number.
- Standard **bold text** is used to emphasize items within instructional sequences or indicate a navigational path you must follow to locate/start a software application, open or save a file on your workstation PC, or perform an operation when working with Insight. The > character is used to separate items within a navigational path. For example, navigate to **File > Open** from the Main Menu.

Symbols and Notes

The following symbols are used throughout this manual to highlight information, references and warnings of hazards during printer use or when performing specific tasks.

Symbol	Meaning
	Warning: Indicates a potentially hazardous situation which, if not avoided, may result in injury or death. A Warning precedes the relative paragraph.
	Caution: Indicates a situation which, if not avoided, could result in damage to equipment. A Caution precedes the relative paragraph.
	Note: Indicates additional information relative to the current topic. A Note follows the relative paragraph.
	Refer to documentation Refer to the relevant printer manual or safety data sheet.

Service and Software Support

If you have a problem with your printer or software that is not covered in this guide, please contact Stratasys Customer Support. Contact information is available from the Stratasys website at: <https://support.stratasys.com/en/contact-us>.

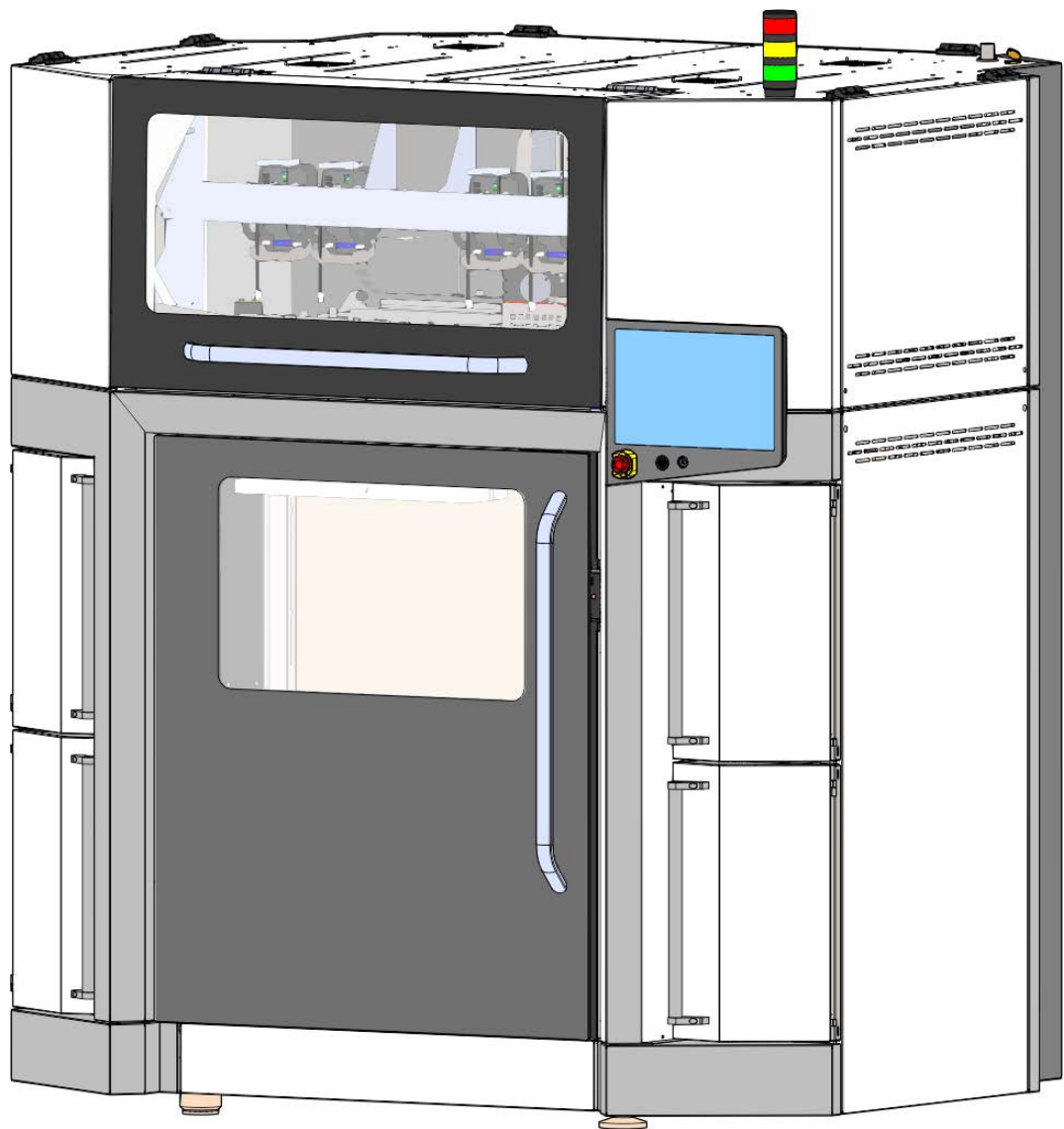
When calling in for service, always have your printer's software version (see "[Software Version](#)" on page 191) and hardware serial number available (see "[Identifying Your Printer](#)" on page 68). You may also need to provide a configuration file from your hardware (see "[Exporting System Configuration \(*.CFG\) File](#)" on page 208).

2 Introducing the 3D Printing System

This chapter describes the components of the F3300 printer. Information regarding the materials and tips that can be used by the printer is also included in this chapter.

Printer Overview

Figure 1: F3300 Printer



Features

The Stratasys F3300 3D printer uses the latest technical innovations and Stratasys' Fused Deposition Modeling (FDM) technology to provide precise prototype parts, including internal features, that can be used to field-test form, fit, and function. Direct Digital Manufacturing (DDM) allows for the creation of customized end-use parts straight from 3D CAD data. For printer dimensions and site requirements, see the *F3300 Site Preparation Guide*.

Highlights:

- Maximum build area of 600 x 600 x 800 mm (23.6 x 23.6 x 31.5 inches)
- Integrated tool changer with capacity for four extruders
- Four heated, drier equipped, material bays (1 CFM -60C supplied)
- Automatic calibration
- Large touchscreen graphical user interface
- Two internal cameras, front and rear viewing, for remote monitoring
- GrabCAD Print Software Package
- Insight Software package

Technical Characteristics

AC Power Requirements	Voltage: 120/208V 3W+N+PE Current: 23.0 Amps 50/60 Hz
Nominal Power Consumption	
ULTEM™ 9085 filament	
• Building	4140W
PC	
• Building	3440W
Nylon12CF	
• Building	2740W
ASA Material	
• Building	1860W
Layer Resolutions	0.1875 mm (0.00738 in.) 0.25 mm (0.00984 in.) 0.50 mm (0.01969 in.)
Dimensional Accuracy (X,Y and Z)	XY part accuracy = ± 0.089 mm (± 0.0035 in.) or ± 0.0015 mm/mm (± 0.0015 in./in.) whichever is greater Z part accuracy = ± 0.200 mm (± 0.008 in.) or ± 0.002 mm/mm (± 0.002 in./in.), plus 1 layer height. Accuracy is geometry and material dependent. Achievable accuracy specification derived from statistical data at 95% dimensional yield.

Environmental Requirements

- The F3300 printer is for indoor use only.
- Air quality conditions with excessive solid particulates (conductive or non-conductive) may result in system damage.
- Air quality conditions in which airborne oils are allowed to accumulate on or within the printer can damage the plastic components.
- System operating temperature shall be in the range of 15°C to 30°C (60°F to 86°F), with relative humidity range of 20% to 80% non-condensing.
- System storage temperature shall be in the range of 0°C to 35°C (32°F to 95°F), with relative humidity range of 20% to 90% non-condensing.
- Altitude shall not exceed 2000 m (6561 ft).
- Material storage shall be in the range of 13°C to 30°C (55°F to 86°F), with relative humidity less than 70%.
- Noise emission (acoustic): <62 dBA when idle and when building.

Access Doors and Panels



Do not energize when the rear or side panels are not secured in place.

This printer has been designed to allow easy access to the most frequently accessed areas on the system. Doors and panels are highlighted in [Figure 2](#) and [Figure 3](#).

Figure 2: Access Doors and Panels - Front View

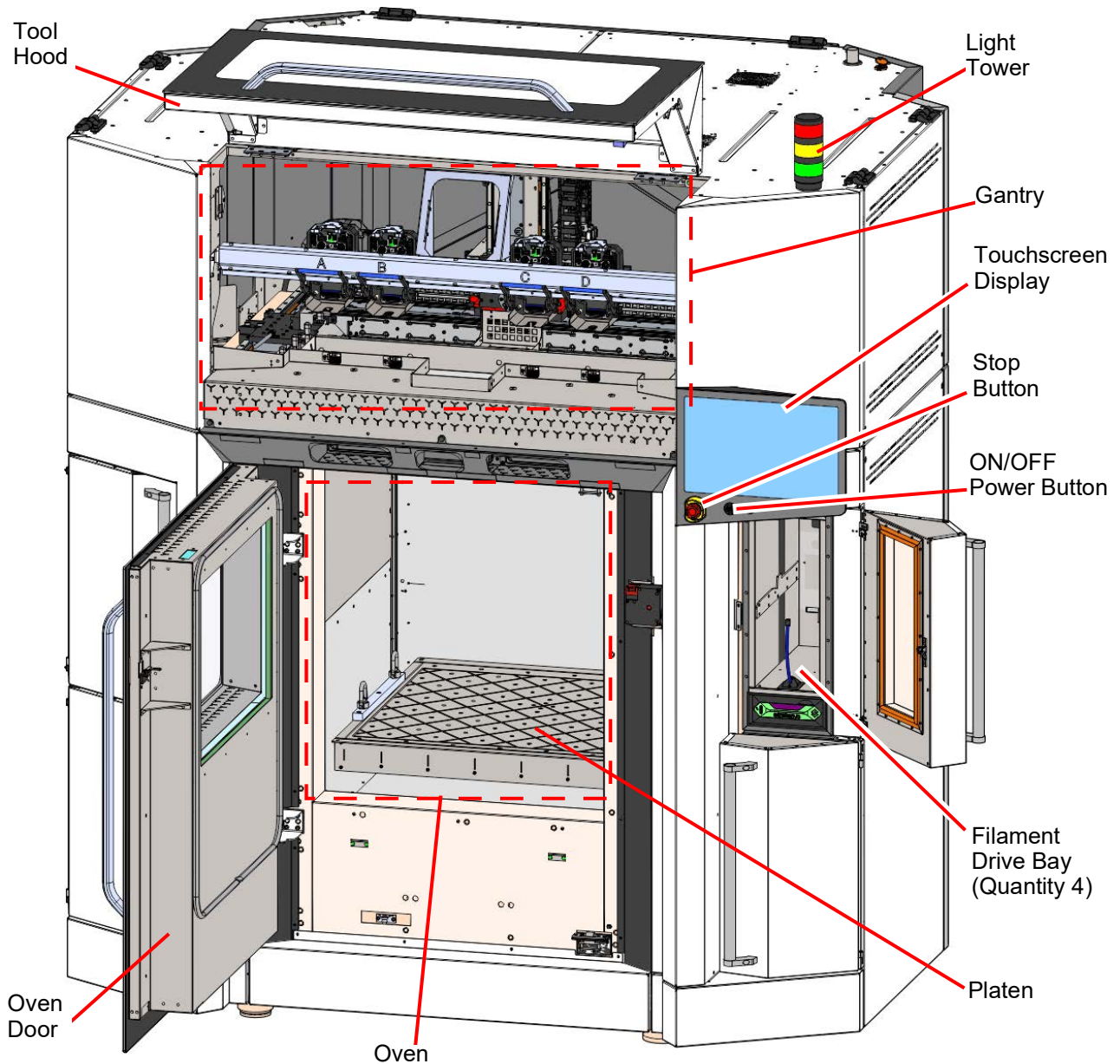


Figure 3: Access Doors and Panels - Rear View

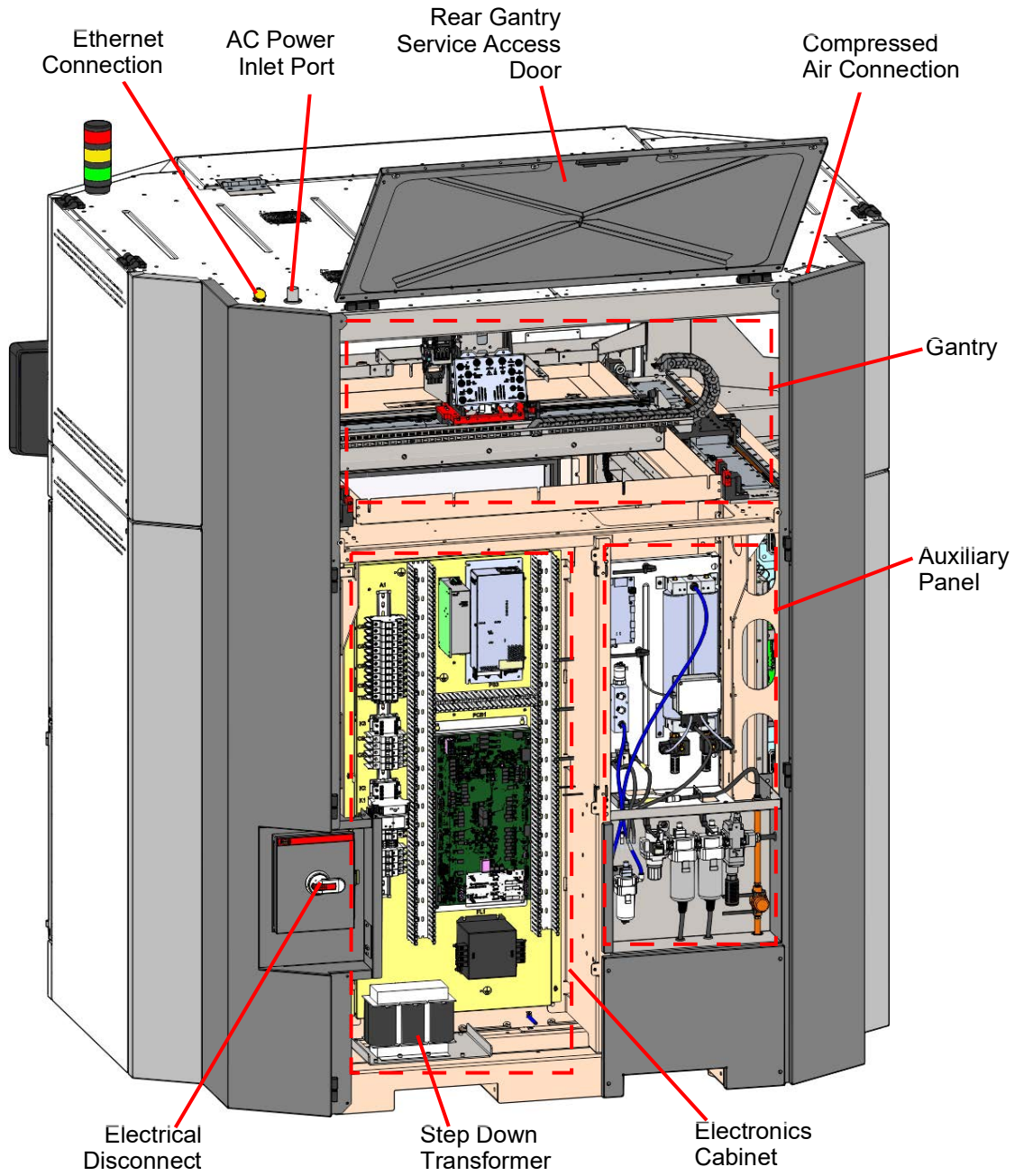


Figure 4: Left side view

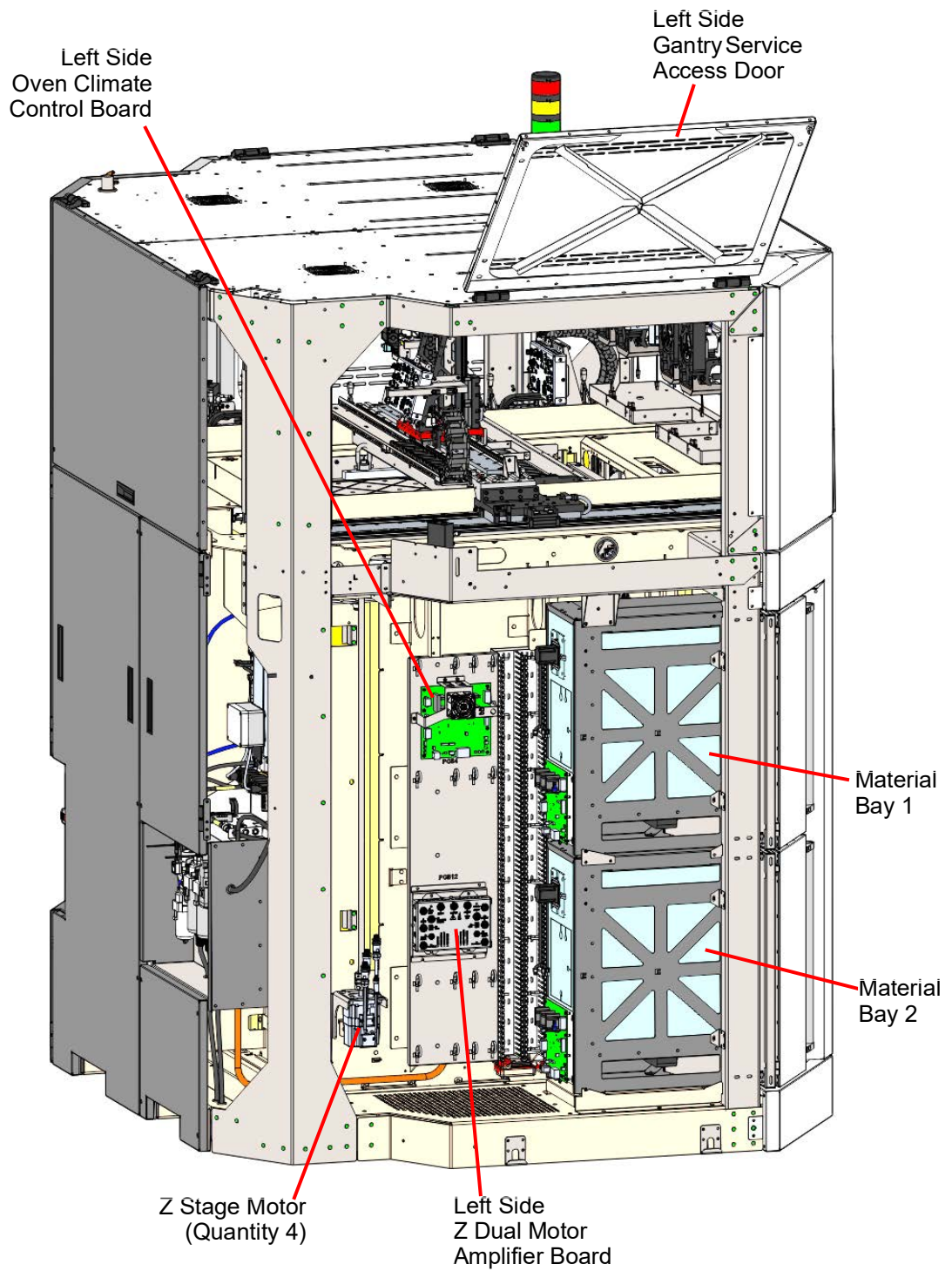


Figure 5: Right side view

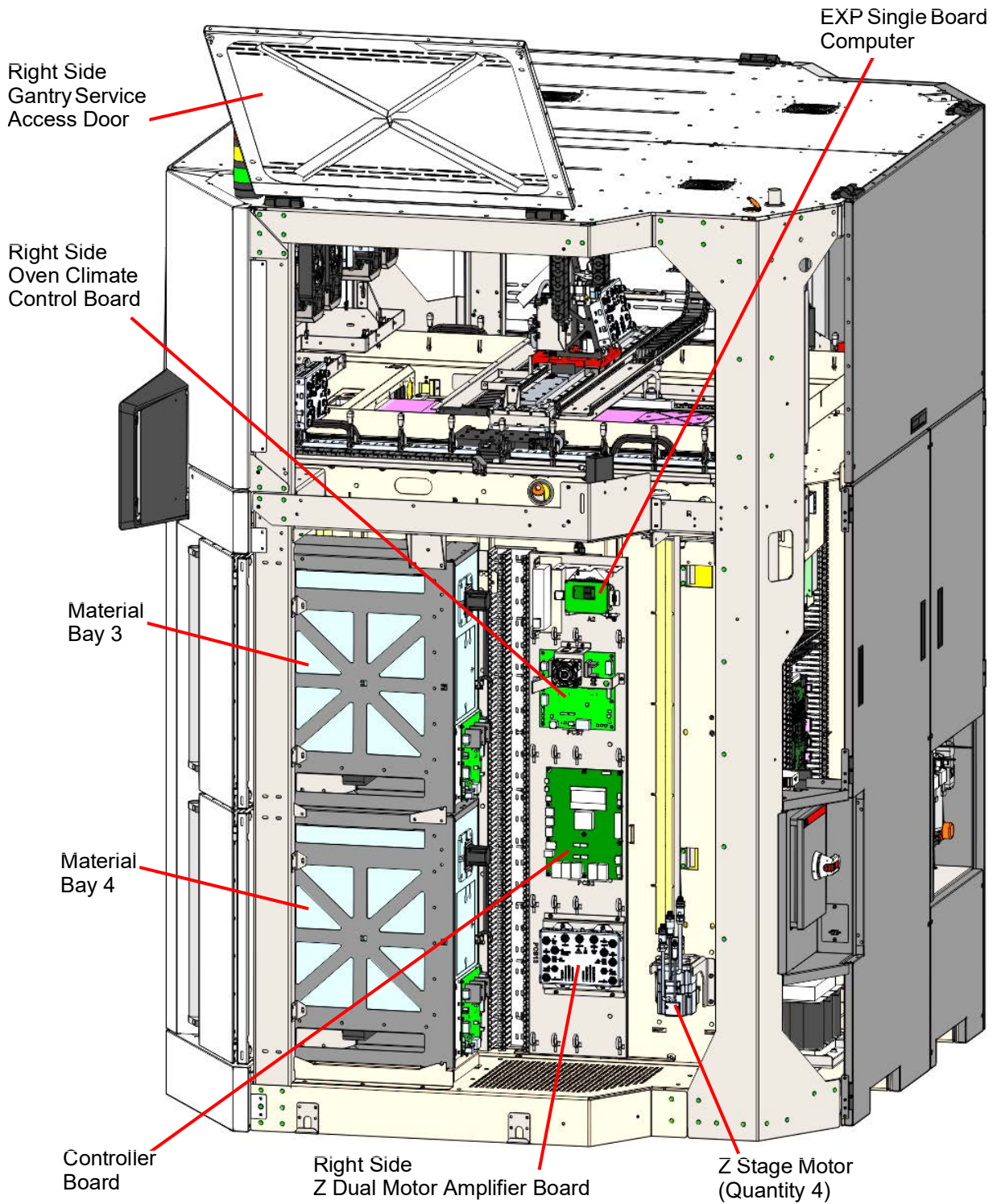


Figure 6: Gantry detail (Y bellows not shown)

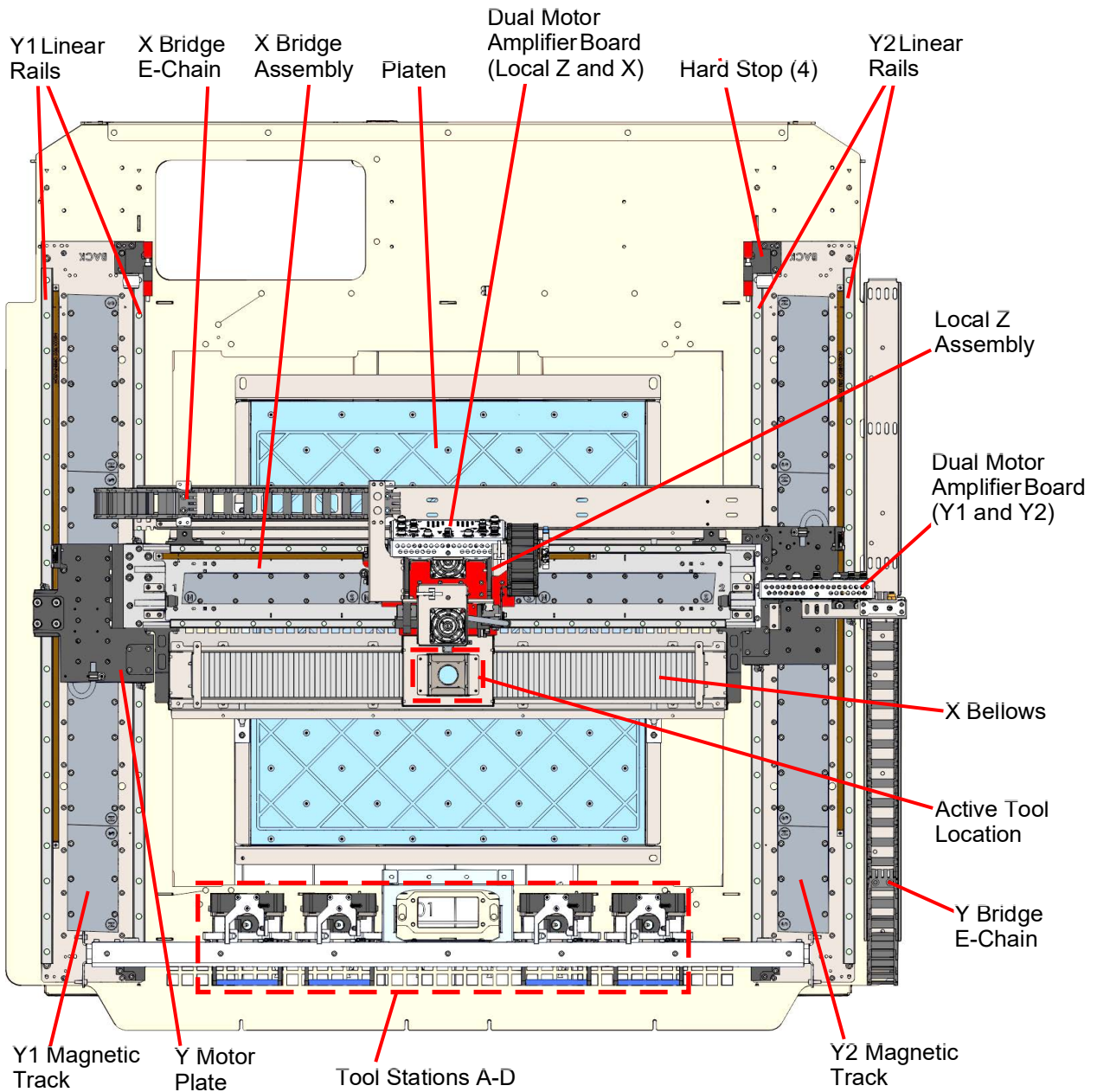


Figure 7: Electronics cabinet detail

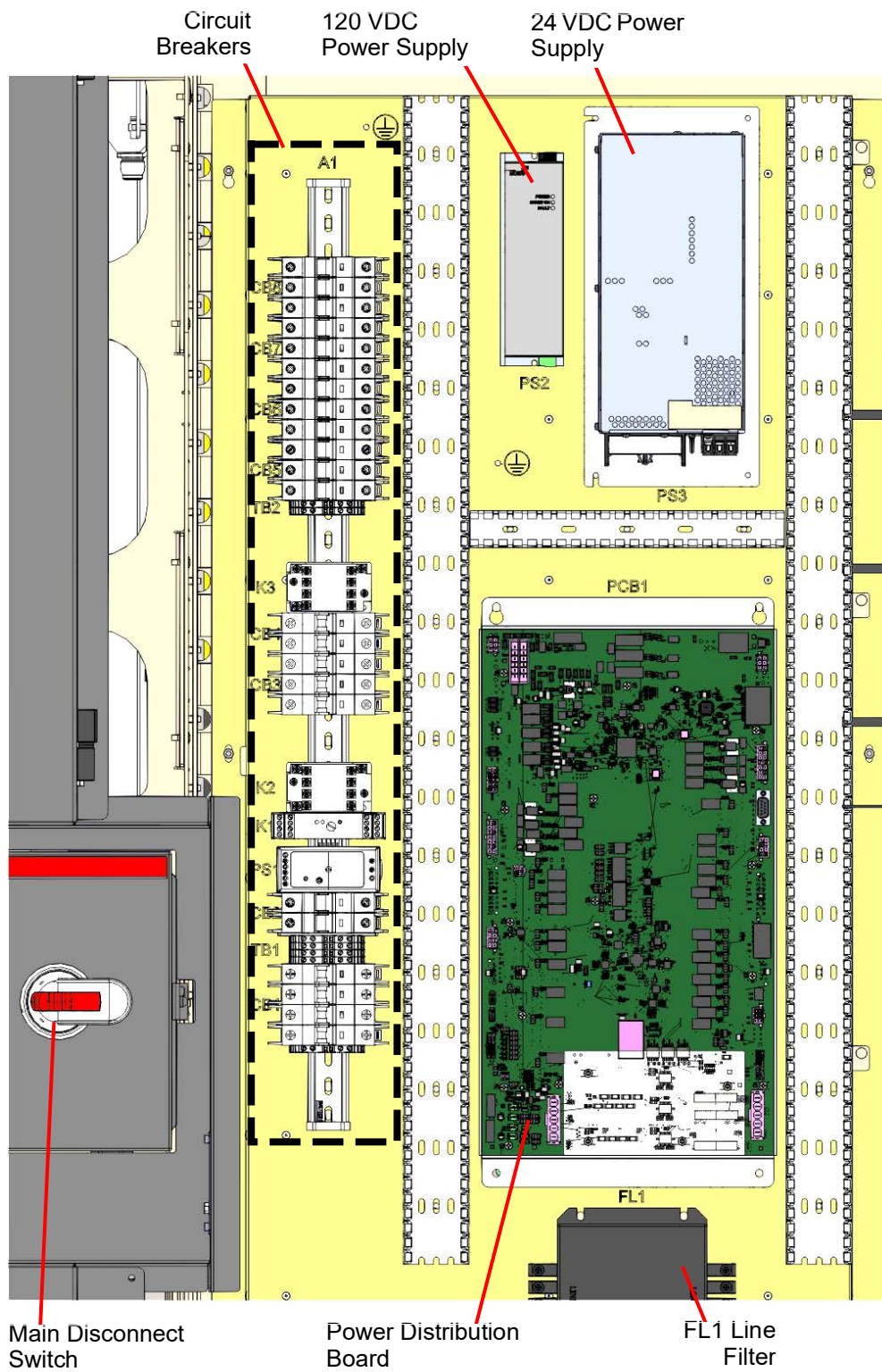
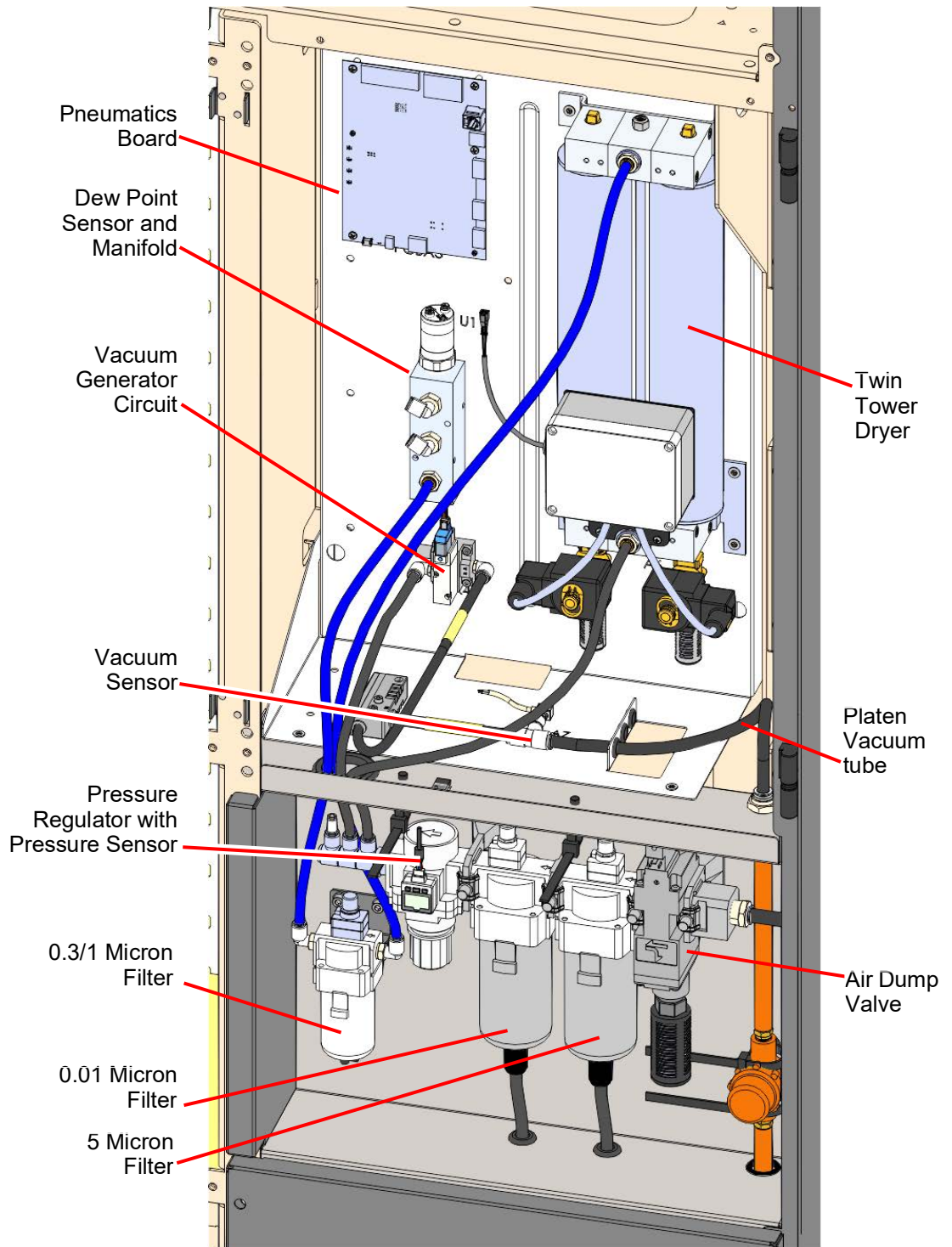


Figure 8: Pneumatics panel detail

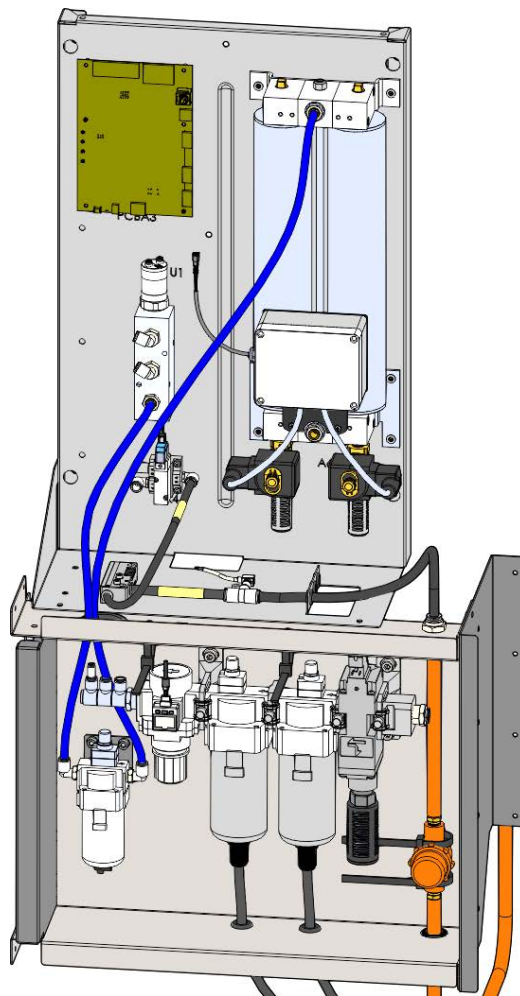


Pneumatics Panel

The pneumatics panel is located on back of the printer and serviced through the access panels or the user-accessible area underneath.

Pneumatics CCA in the auxiliary panel is used for vacuum generation and air drying. These functions are performed using an external compressed air source (non-lubricated) at 90-120 psi). Dry air is supplied to the material bay and the filament path, which keeps the material in the material bay and filament path dry.

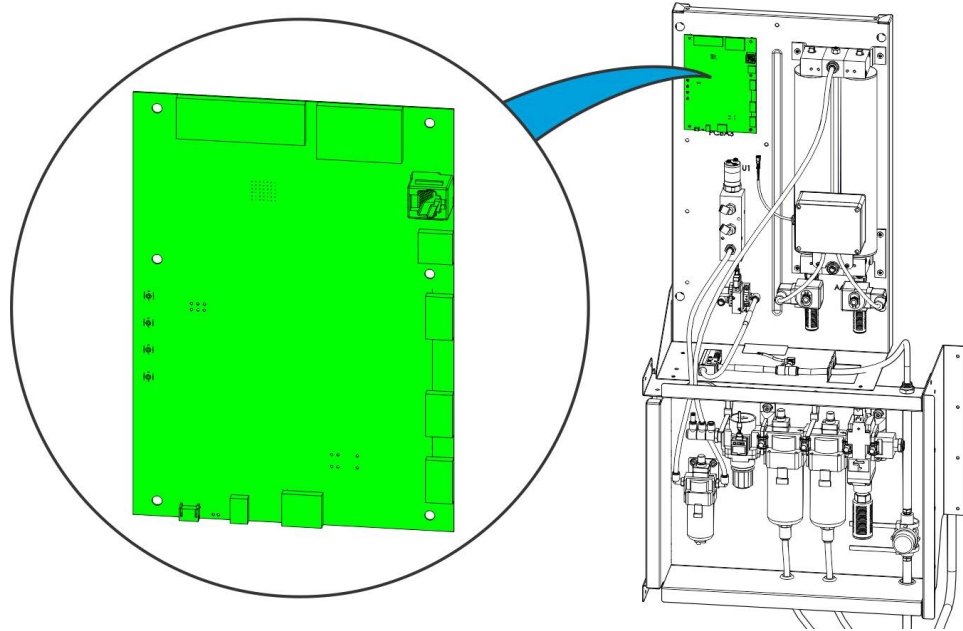
Figure 9: Auxiliary Panel Detail



Pneumatics Board

The pneumatics board is located on back of the printer on the auxiliary panel, behind the access panel. It controls the vacuum using a vacuum sensor and a valve as well as the air pressure using an air pressure sensor and a dump valve). The pneumatics board also controls the dryer by using a DP sensor and the twin tower dryer. The pneumatics board uses an external temperature and humidity sensor to monitor ambient conditions.

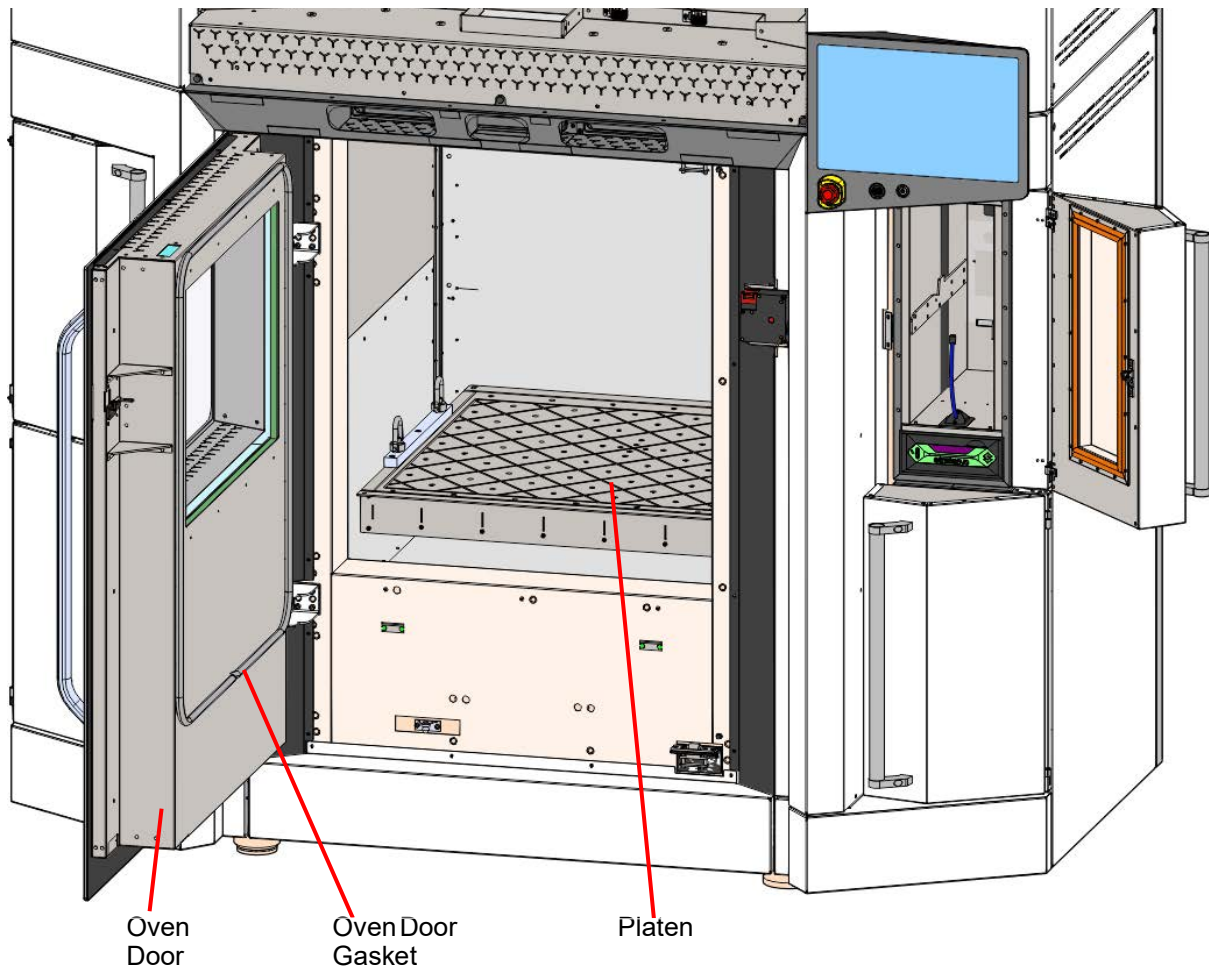
Figure 10: Pneumatics Board Location



Oven Components

The oven consists of the oven door and everything that you see through the oven door window, including the platen and oven heaters. The printer contains two cameras. The rear facing camera is located in the door frame and the forward facing camera is located in the back wall of the oven.

Figure 11: Oven Components



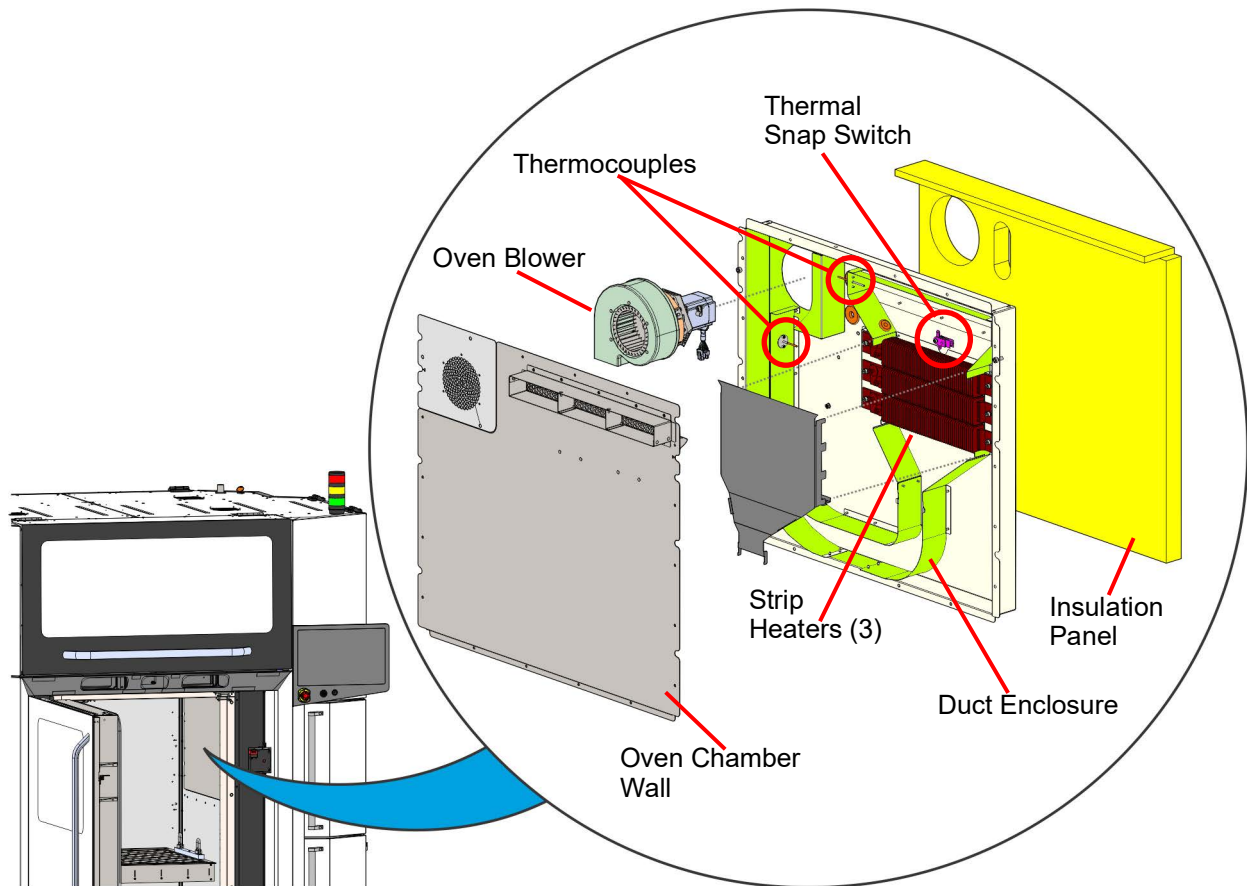
The oven chamber walls are made from 20 gauge stainless steel. Insulation panels are captured between the frame and oven walls. Airflow temperature and velocity are managed through the use of duct enclosures on the left and right sides of the oven.

Each duct panel assembly contains three 900W AC, 208v fin strip heaters, an adjustable speed DC blower, a control thermocouple, and a thermal snap switch. Airflow is forced from each duct assembly into the oven at the build plane. To ensure proper operating temperature, the oven temperature control uses feedback from an inlet and an outlet thermocouple on each heater assembly which are each controlled independently from each other to ensure proper operating temperature. Oven blowers must be above 500 RPM for heaters to activate.

There are two automatically resetting thermal snap switches (one per oven side) as an additional safety measure to prevent runaway temperature. They are tripped at 288° C (550° F).

i Although the thermo snap switches reset automatically, the printer must be shut down and restarted to operate properly.

Figure 12: Duct Panel Detail

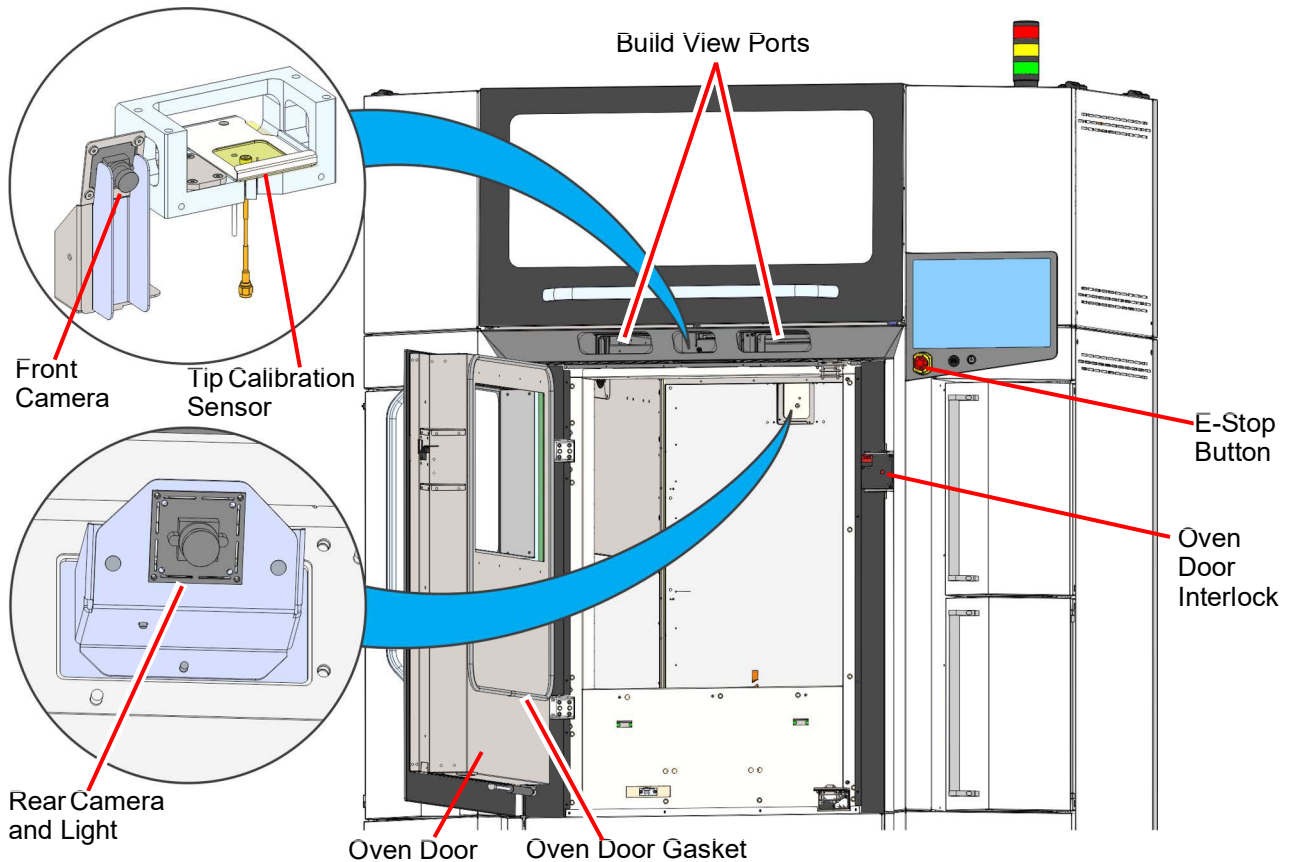


The oven door is constructed with a steel frame containing an inner window of double pane tempered glass and an outer silk-screened lexan sheet. A stainless steel door gasket provides a seal for the oven when the door is closed. A safety-rated door latch senses when the door is closed and locks the door during build or XYZ axis movement. When the hood or the oven door is opened, the safety circuit is engaged. When the safety circuit is engaged, the STO (Safe Torque Off) circuit in the drives is set. This prevents the motors from being enabled.

When the platen is at model start height, it is actually above the top of the oven door, so two view ports above the door provides a view of the part during the first inches of build. Two cameras with LED lighting are mounted outside the top front and rear of the heated oven chamber, viewing through glass barriers. The cameras offer viewing of the build chamber either directly, using the touchscreen, or remotely through Control Center or GrabCAD Print. The update rate is approximately once every 10 seconds.

An E-stop button is located beneath the user interface. When pressed, the button will trip the safety relay, and the STO (Safe Torque Off) circuit in the drives is set when the safety circuit is engaged. Engaging the STO circuit also stops any active X, Y, and Z motion. Engaging the STO circuit also prevents the drives from being enabled until the circuit is reset either by closing the door or hood, or resetting the E-stop by rotating clockwise.

Figure 13: Oven Door Detail

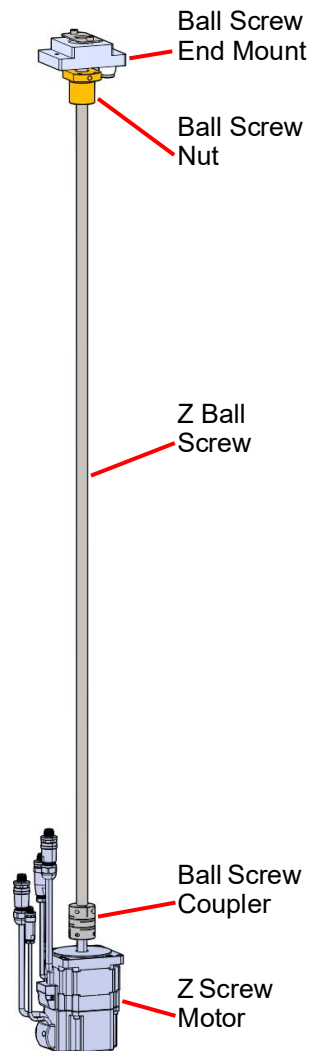


Z Stage

The F3300 Z stage is driven with four ball screws - one in each corner of the printer frame. A ball screw nut on each ball screw carries the platen assembly. The ball screws are driven by 120 VDC motors which move the platen into position as the part is being built. The Z stage is responsible for Z-axis positioning to adhere the first layer to the build sheet and to maintain accurate layer thickness thereafter. Each motor has a brake to prevent the Z stage from falling when power is disabled to the motors. Brake control is also performed by the Z motor amplifier assembly, when a motor fault occurs or the motor is disabled.

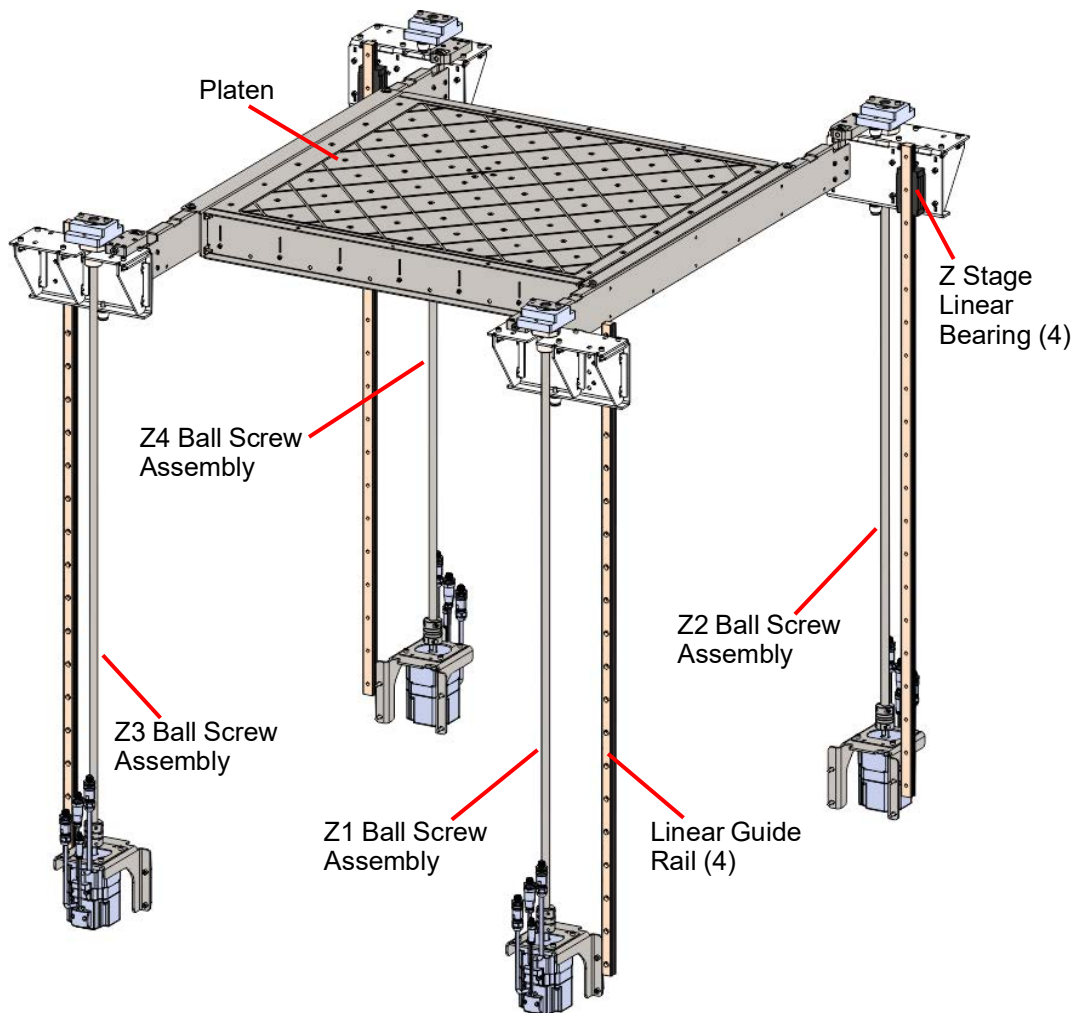
The platen is automatically leveled after each power up during the calibration cycle. Each ball screw is used independently to level the platen based on the touch off from the local Z on the gantry.

Figure 14: Z Ball Screw Assembly



The platen is bolted onto two assemblies that bridge the oven and tie the four ball screw assemblies together to form the Z stage assembly. The platen has grooves that are used to secure the build sheet through vacuum. Vacuum pressure is generated by a venturi located in the pneumatics panel in the rear of the printer. A 0.020" build sheet covers the full build area and is held in place by the vacuum. A vacuum switch detects when at least 20 in Hg vacuum pressure is achieved. The system will not allow a job to start until vacuum is achieved. An F3300 platen can support a maximum part weight of 91 Kg (200 lbs) which is approximately 22 ASA 250ci spools, 4.5 weeks of build time at 8 ci/hr.

Figure 15: Z Stage



Gantry

X, Y, and Local Z Motion Components

The F3300 printer features a dual Y, H-style, gantry with a local Z stage. Each axis is driven by linear motors and encoders. Each shuttle or bearing set incorporates two profiled, linear guides with two bearings on the primary rails and one bearing on the secondary rails. The primary rails provide the positioning, while the secondary rails and cars provide vertical support for the linear motor. Shuttle mounting blocks span the primary to secondary linear rails. The X profiled linear guides are mounted to the X bridge, which mounts to the Y1 and Y2 shuttles using a rigid joint on Y1 and an expansion joint or flexure on Y2. This allows for independent control of the Y1 and Y2 motors, as well as accommodating thermal expansion differences between the oven frame and the bridge.



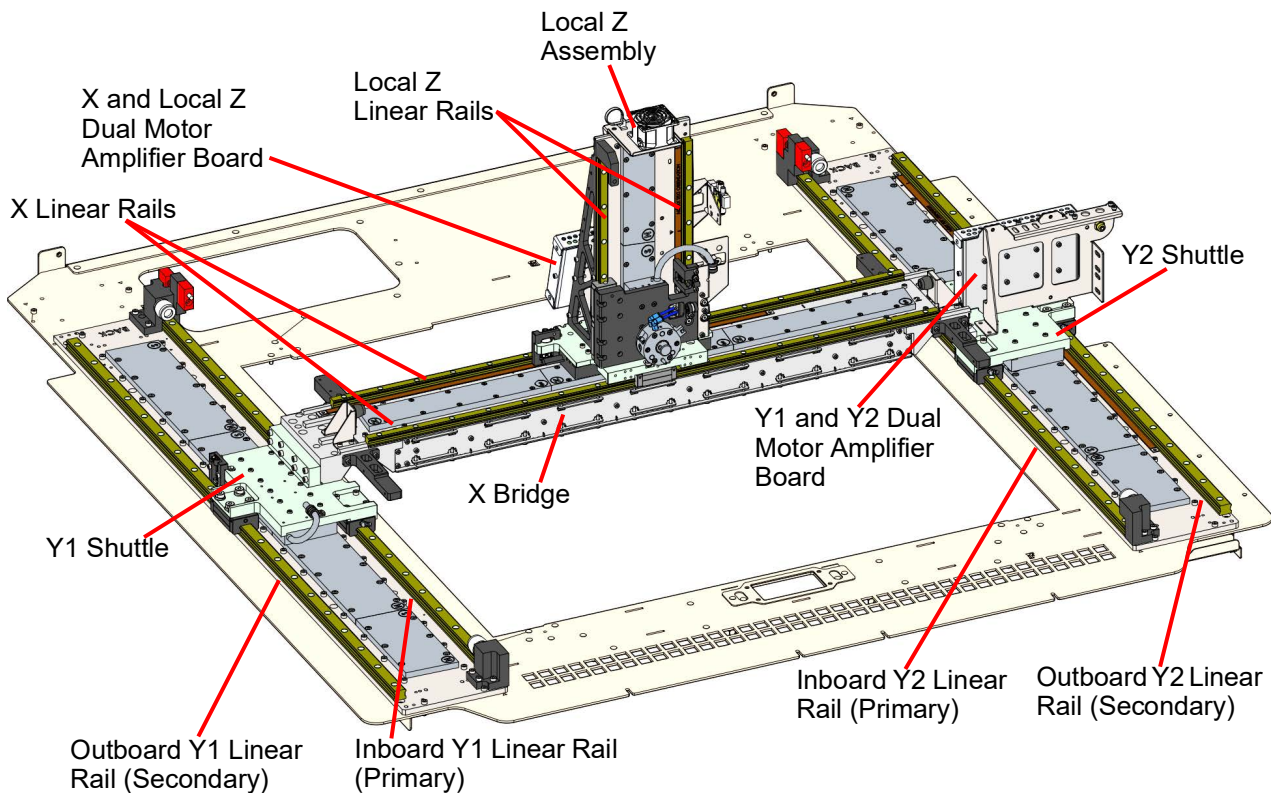
The inboard Y1 rail is the primary rail and has two bearing cars. The outboard Y1 rail is the secondary rail and has only one bearing car. The Y1 side has a fixed joint and drives a majority of the bridge motion.

The inboard Y2 rail is the primary rail and has two bearing cars. The outboard Y2 rail is the secondary rail and has only one bearing car. The Y2 side has a flexure.

Fans (4) are located above each corner of the gantry to maintain cool temperatures above the oven chamber. Additionally, one fan is mounted to the top of the local Z assembly and another fan is mounted to the X motor plate.

There are two Dual Motor Amplifier boards that function as motion control and amplifier boards. The Motor Amplifier board mounted to the Local Z assembly controls X and Local Z motion. The Motor Amplifier board mounted to the Y2 shuttle controls Y1 and Y2 motion.

Figure 16: Gantry Rails and X Bridge Detail



Drive and control of the X, Y and local Z axes is provided by linear motors. The fixed magnet (stator) side of the linear motors are mounted to the machine frame or track components. The electromagnetic motor (armature) is secured to each of the shuttles and travels along the linear guides. Positional feedback is achieved through use of a 1 micron (.00004 inch) resolution magnetic encoder. The magnet strip is affixed to the track components parallel to the linear guide while the read head is attached to each of the shuttles. The linear motors are powered by a 120 VDC power supply.

Figure 17: Y Axis Electromagnetic Components Detail

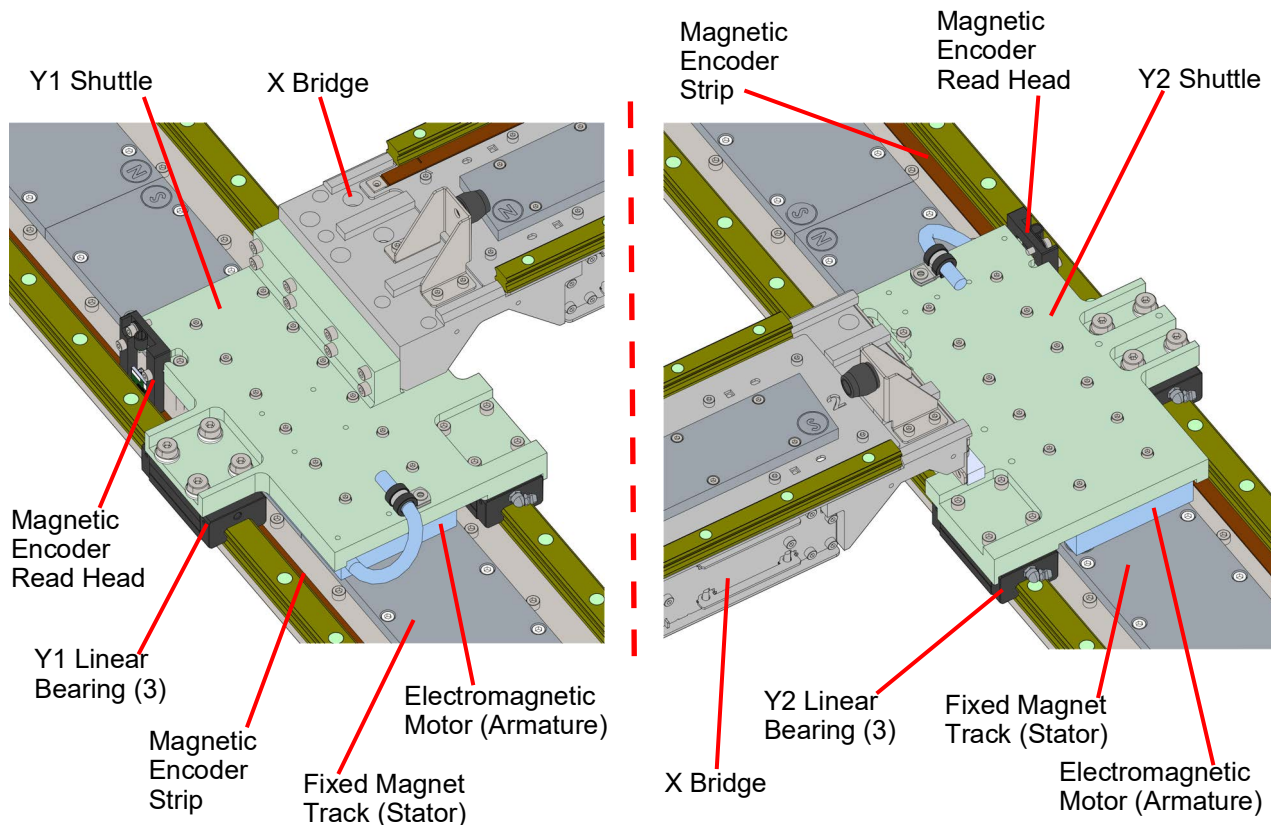
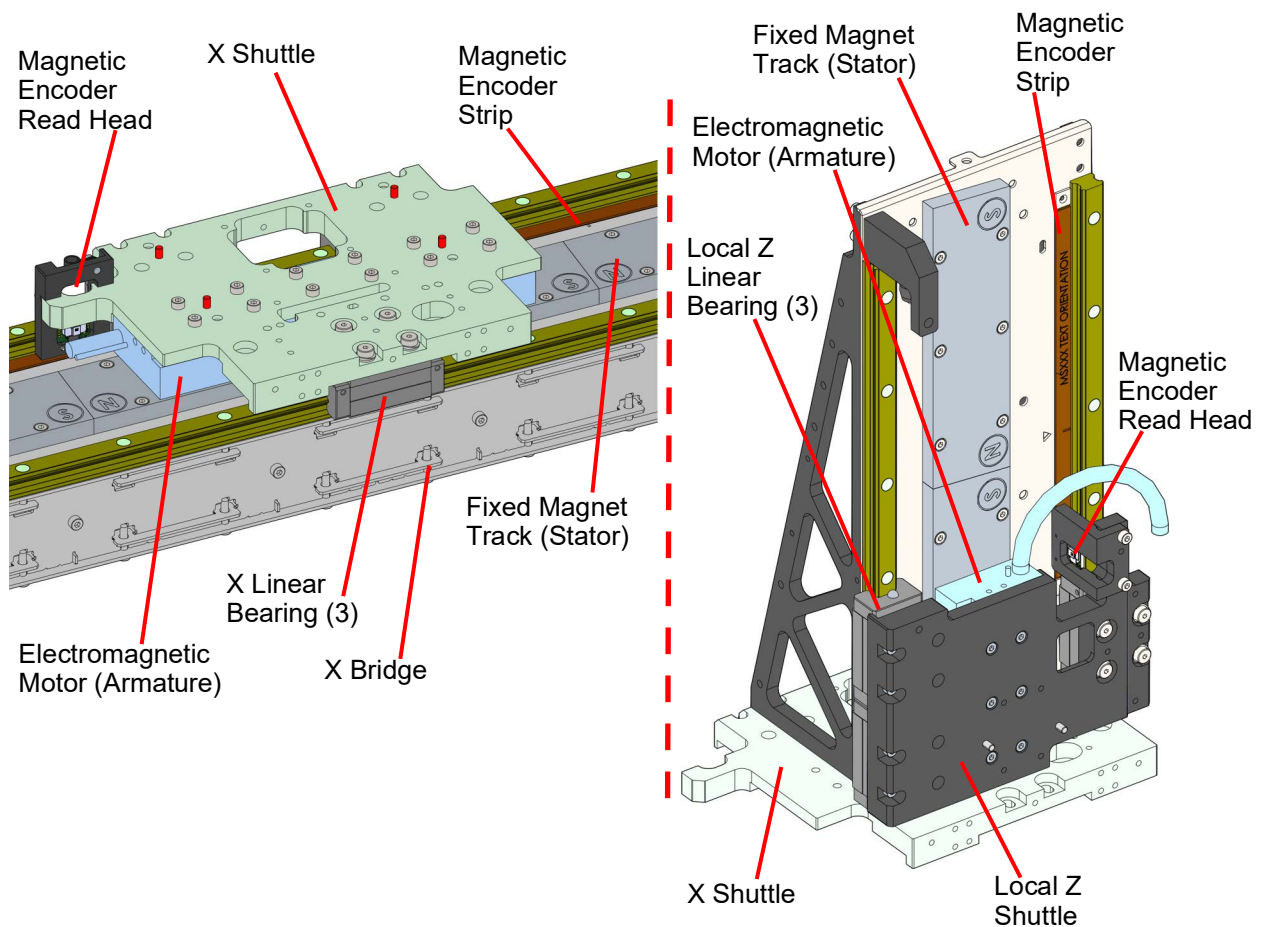


Figure 18: X Bridge and Local Z Electromagnetic Components Detail



Extruders, Tool Rack, and Local Z Assembly

The F3300 3D printer can use up to four separate extruder assemblies for model or support material. Each extruder assembly is comprised of a motor, a hot end, a drive, and a tool base. Once a hot end has been used for model or support, it can only be used for that designated material (model or support) thereafter. For example, if ASA is loaded into a Hot End, that Hot End can only be used with ASA going forward. When new, Hot Ends can be used with any material applicable to that Hot End.

The extruder assemblies are designed for use with a range of modeling materials. The extruder assemblies can extrude model material or support material. A single blower fan, mounted above the hot end entrances, cools the incoming material. The extruder assemblies are considered a consumable items.

An EPROM on the extruder motor tracks motor life. There is also an EPROM on the hot end that tracks material type, build hours, serial number and calibration data. The tool base CCA (TEB) has the motor controller, head buttons, and power management.

The extrusion motor control and hot end thermal control is handled by the TEB board. The fan is used to control the temperature at the inlet of the hot end and will turn on or off based on the temperature of the hot end, as well as varying speed based on filament flow rates. The hot end contains dual heaters and two thermocouples. The heaters are located in separate zones and are controlled individually based on the extrusion rate. The extrusion motor is a DC motor with an encoder that drives a gear reduction drive block assembly.

There are four separate tool docks on the front of the printer tool rack. Each tool dock is capable of housing a tool base with an extruder. Each tool base is retained on the tool dock using magnets and two alignment pins. The extruder is secured onto the tool base using threaded fasteners and two guide pins. The hot end is secured to the extruder drive by a single clamp screw.

**CAUTION: Damage to Equipment**

It is critical that the clamp screw is tightened when installing the hot end on the drive. Failure to do so will result in damage to the printer. See [Figure 160 \(page 151\)](#).

The tool changer is located on the Local Z stage and can engage with each of the four tool dock locations.

The tool change area, which is located just behind the hood, houses the purge area and two tip wipe assemblies. The tip wipe assemblies are used to clean the ends of the tips after purging. At the start of the build process, the extruders will purge a small amount of material into the purge area and then wipe the tips to improve build quality.

Figure 19: Tool base and extruder configuration

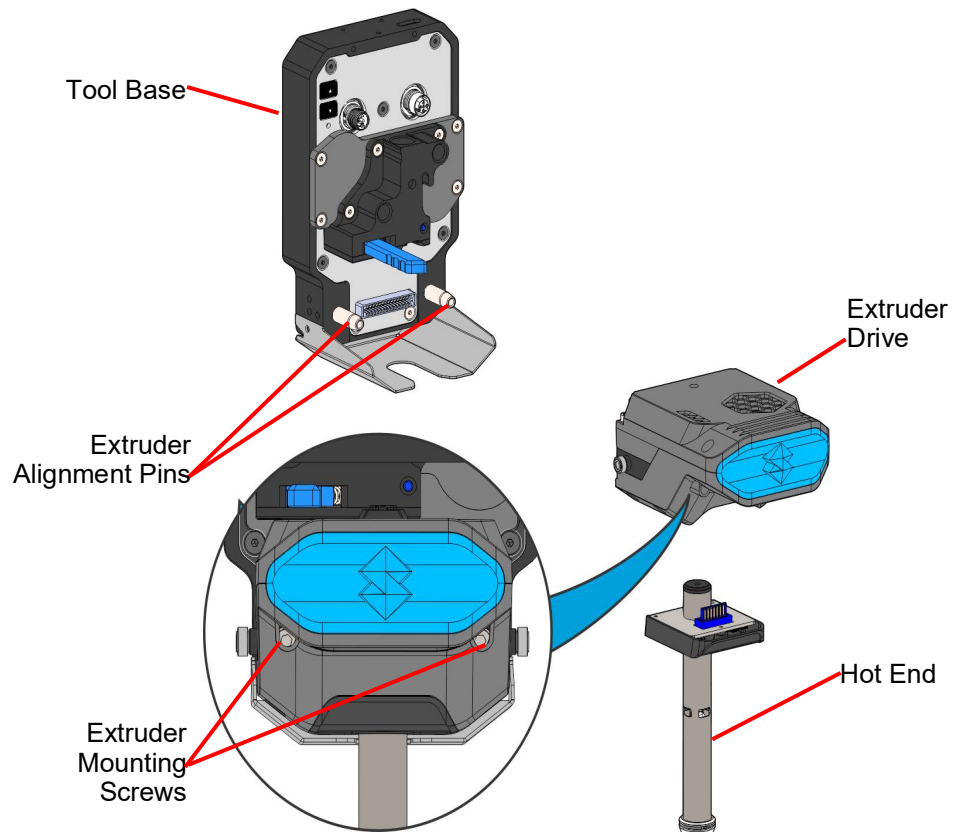
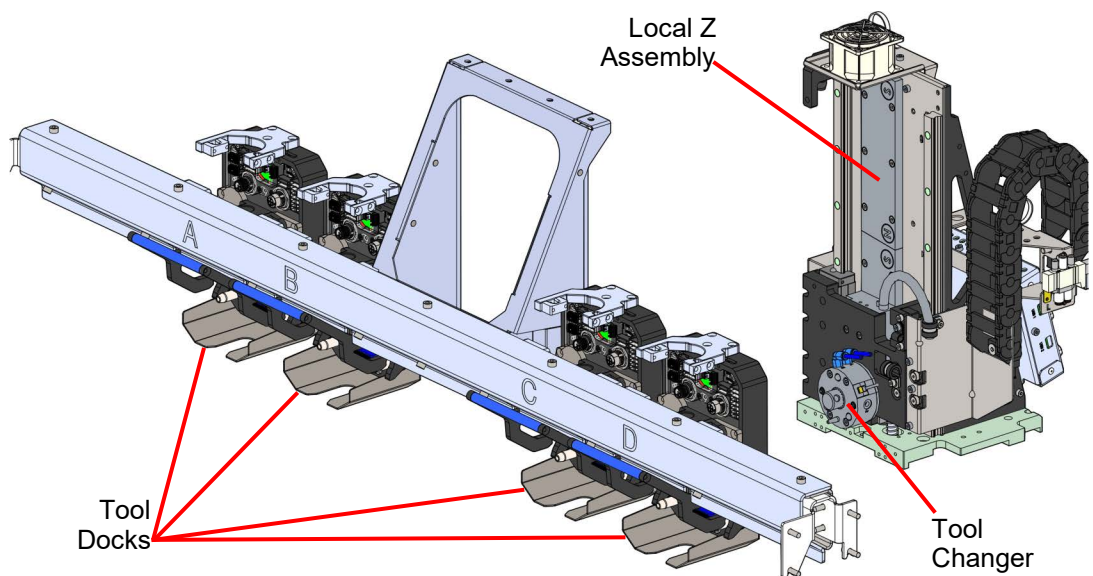


Figure 20: Local Z Assembly and Tool Docks

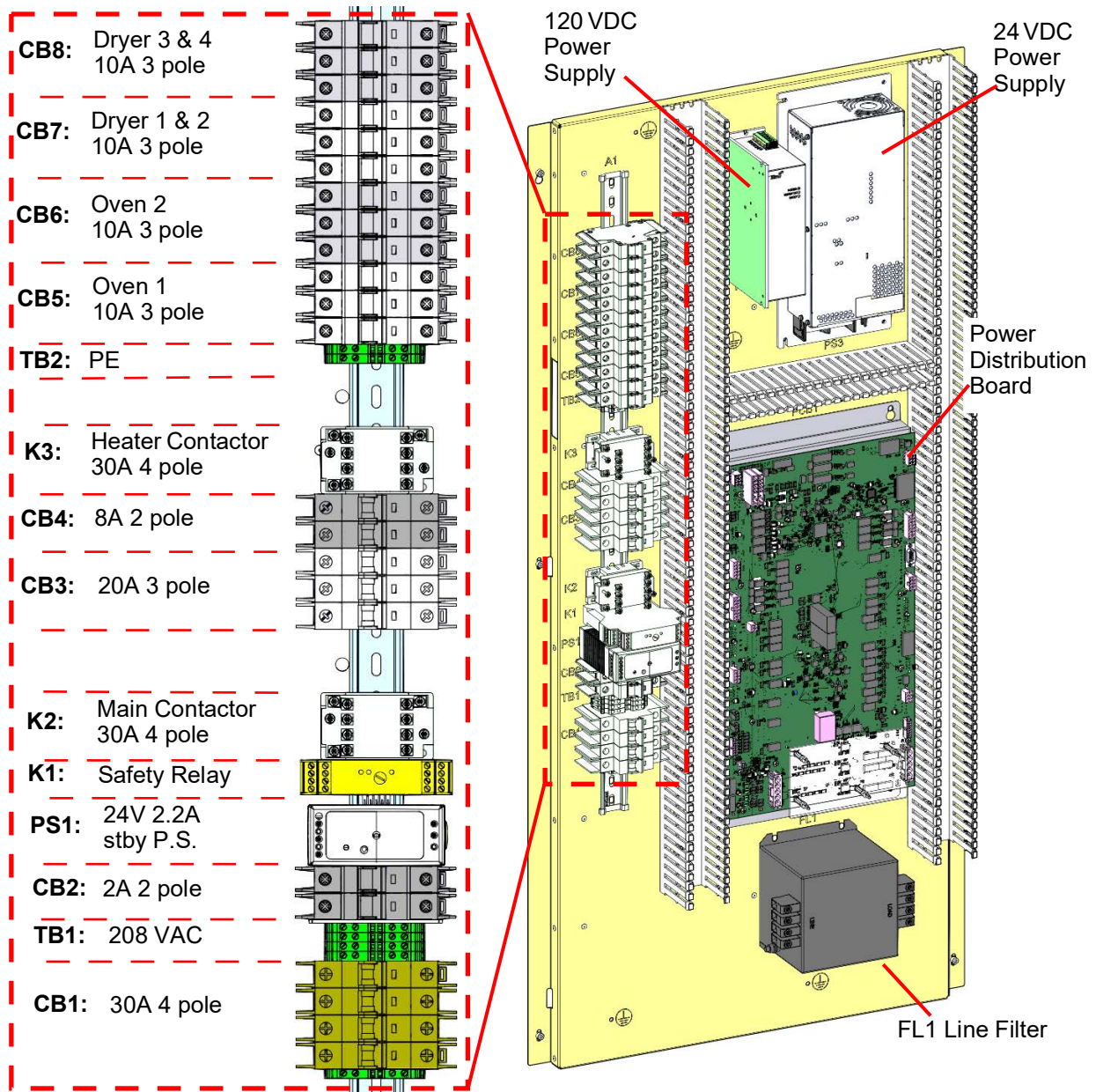


Electronics Panels and Boards

Electronics Panel

The F3300 electronics panel is located in the back of the printer behind the rear panels. It contains the Power Distribution Board, an AC line filter, 24 VDC, and 120 VDC power supplies. It also houses the circuit breakers and contactors detailed in [Figure 21](#).

Figure 21: Electronics Panel Components

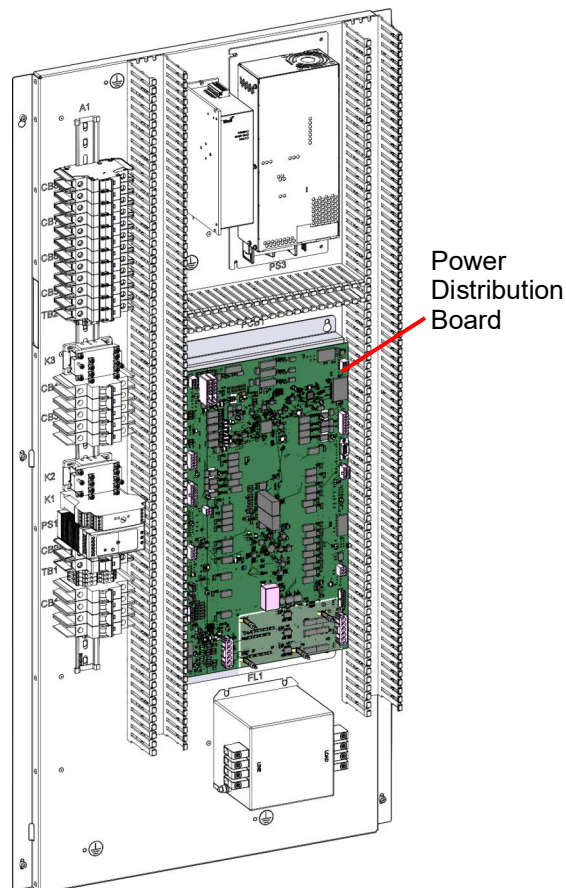


Power Distribution Board

The Power Distribution Board (PDB) monitors voltage and current for incoming 208 VAC along with voltage and current for internal 120 VDC and 24 VDC. The PDB also protects voltages that are distributed to all other boards and peripherals.

- Monitors incoming 208 VAC, Voltage and current
- Monitors and fuse protects 120 VDC out to DTB's
- Monitors, distributes and fuse protects 24 VDC out to all other boards and peripherals
- Monitors Safety system, including thermal cut-outs
- Monitors main power switch
- Controls main contactors
- Controls power to SBC
- Controls and monitors hood and door latches

Figure 22: Power Distribution Board Location



X,Y, and Local Z Dual Motor Amplifier Boards

There are two Dual Motor Amplifier Boards (DTB) located in the printer gantry area. See [Figure 23](#). The Y-Axis Dual Motor Amplifier Board controls the two linear motors on the left and right sets of Y linear rails. The X and Local Z Axis Motor Amplifier Board controls the X-bridge linear motor and the tool changer assembly 's local Z linear motor.

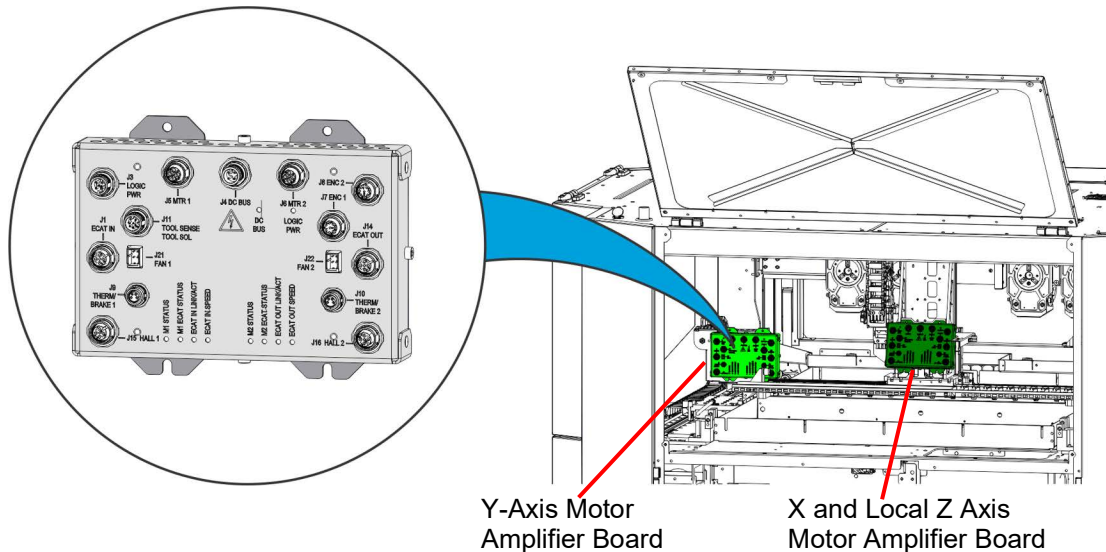
The Dual Motor Amplifier boards contain two preprogrammed BLDC drive and amplifier modules. Each amplifier module can deliver up to 11 amps RMS with a bus voltage up to 120 VDC. The two amplifiers are soldered to a circuit board supplied with motor bus and logic power.

The drive and amplifiers are on the EtherCAT chain. Time sliced commanded positions are sent over the EtherCAT chain from the controller to each axis. The drives use the encoder input to close the PID servo loops.

All communication from the primary controller to the drives carried out using EtherCAT. Any updates are performed using the same Ethernet cables (Ethernet over EtherCAT). There is a USB connector on the CCA for each drive. This USB connector can be used for troubleshooting, updating the drive firmware, or monitoring status.

The X/LZ drive assembly controls the fans on the LZ and X motors as well as the solenoid valve for the tool changer. It also monitors the tool present sensor on the tool changer.

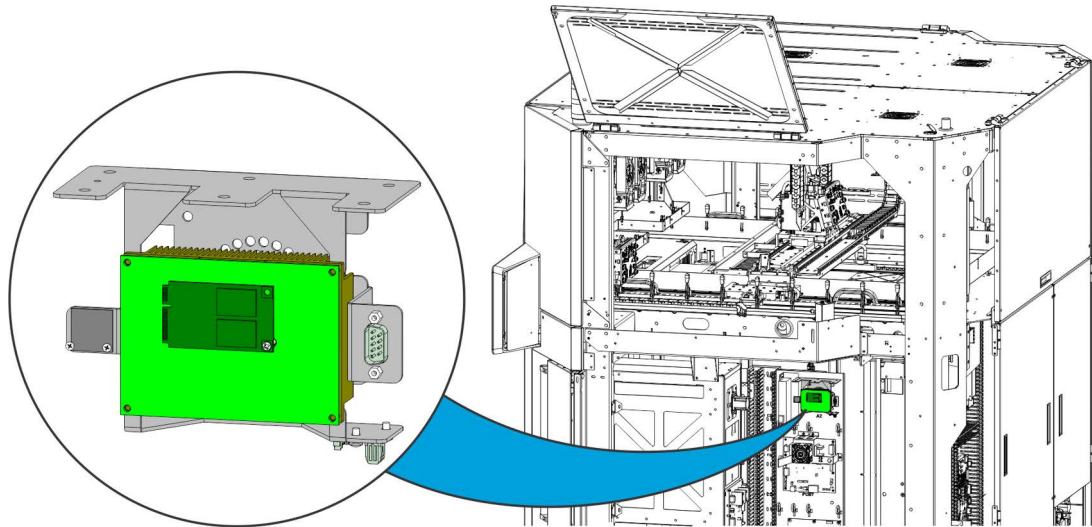
Figure 23: Dual Motor Amplifier Board Locations



Expansion Single Board Computer Board

The Expansion (EXP) Single Board Computer (SBC) is located on the right side of the printer, behind the right-side skin panel, near the back of material bay 3. It provides a secure interface from the F3300 system to external network connections, and also serves as the host computer to run external protocols such as MTConnect. Running external protocols and similar functions on the EXP SBC lessens the burden on the real-time Tarpon Overlord Board (TOB) controller.

Figure 24: EXP Single Board Computer Board Location



Climate Control Board (Oven)

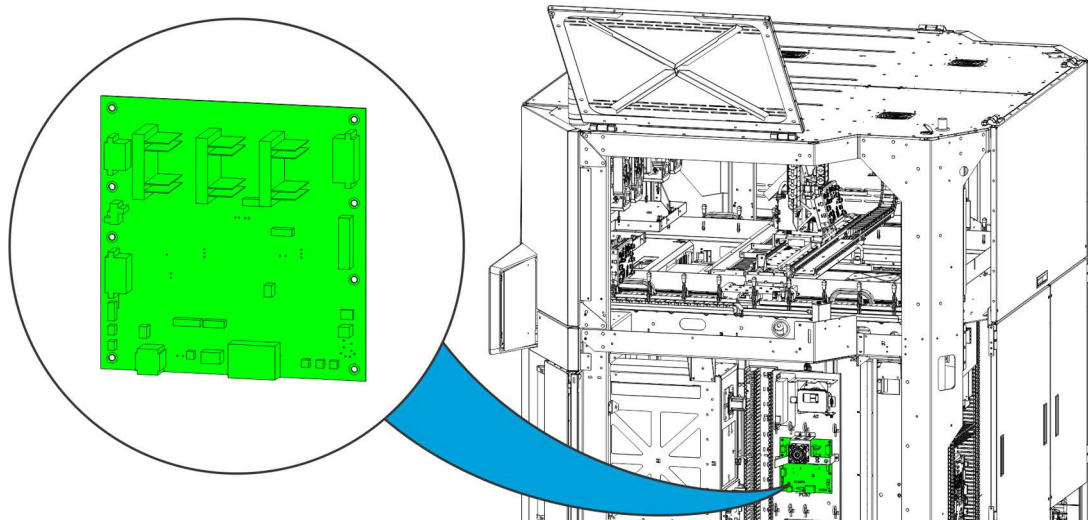


WARNING: High Voltage

Each of the oven climate control boards control 208 VAC power for the oven heaters. Use extreme caution while handling these components. Mishandling these components can result in injury or death.

There are two oven climate control boards. The oven climate control boards are located on the left and right side of the printer, behind the side skin panels, near the back of material bays 1 and 3. They control temperature in the left and right side of the oven chamber as well as controlling the 24V oven blowers (with RPM feedback), monitoring the thermal snap switches, controlling the 208 VAC power for each heater. They also control the tool dock magnets and monitor the tool dock present switches.

Figure 25: Oven Climate Control Board Location (Right Side Shown)

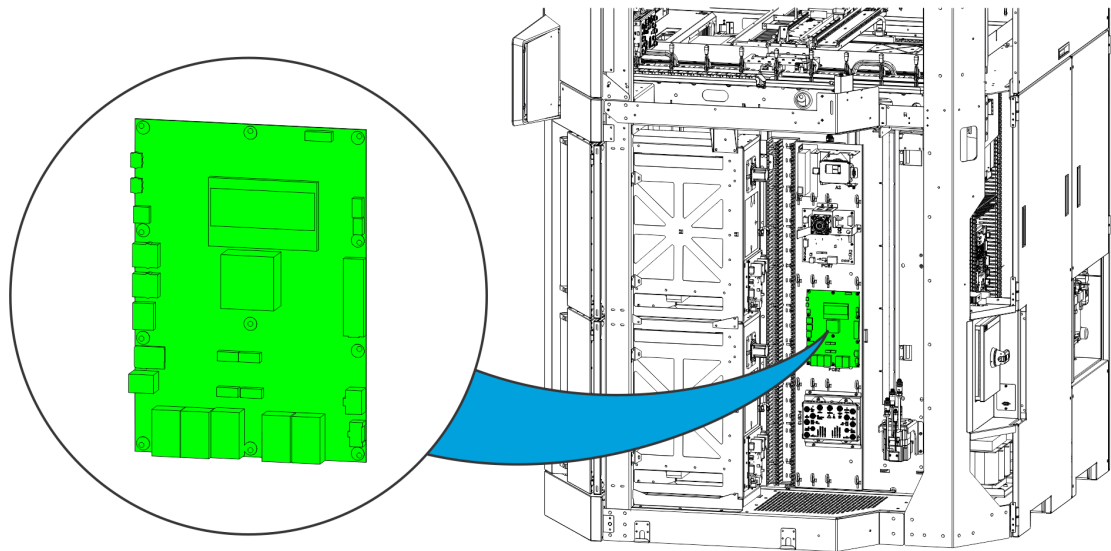


Controller Board

The Controller board is located on the right side of the printer, behind the right-side panel, near the back of material bay 4. The controller contains the EtherCAT controller that commands all the circuit cards and axis on the EtherCAT chain. There are two separate EtherCAT chains. The first one ensures synchronized motion between the gantry, local Z, extruder, and calibration board. The second chain is used for non-critical timing axis items such as the oven and bay control, pneumatics, primary Z stage, and power.

The controller also provides the interface to the USB hub with both cameras, and the EXP SBC with the Ethernet port. It also provides the interface to the front touchscreen display, light tower, and frame ID.

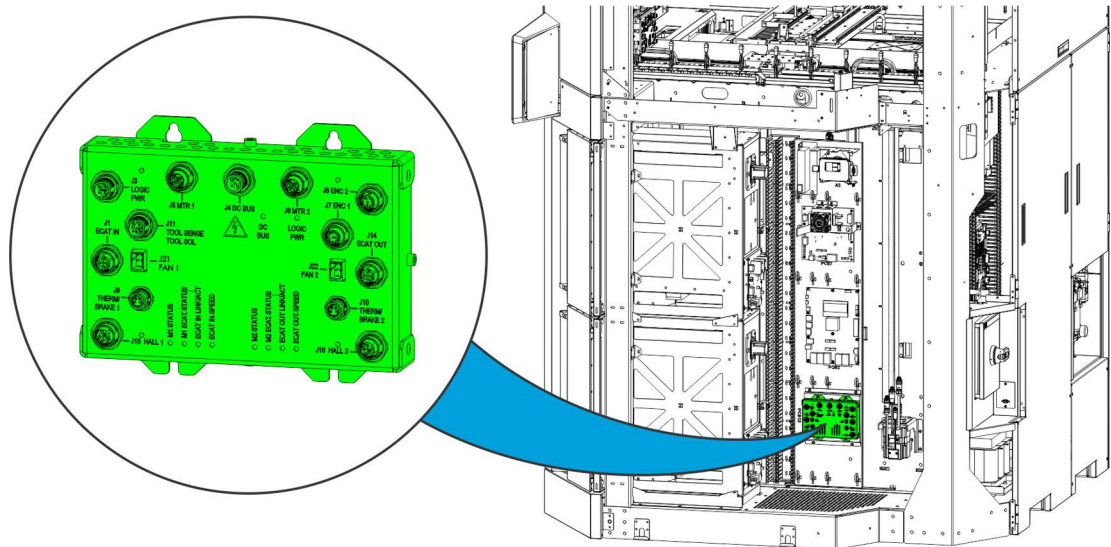
Figure 26: Controller Board Location



Z Stage Dual Motor Amplifier Board

There are two Z Stage Dual Motor Amplifier boards. They are located on the left and right side of the printer, behind the side skin panels, near the back of material bays 2 and 4. The Z Stage Motor Amplifier Boards control the Z ball screw motors (4).

Figure 27: Z Stage Dual Motor Amplifier Board Location (Right Side Shown)



Climate Control Board (Dryer Bay)

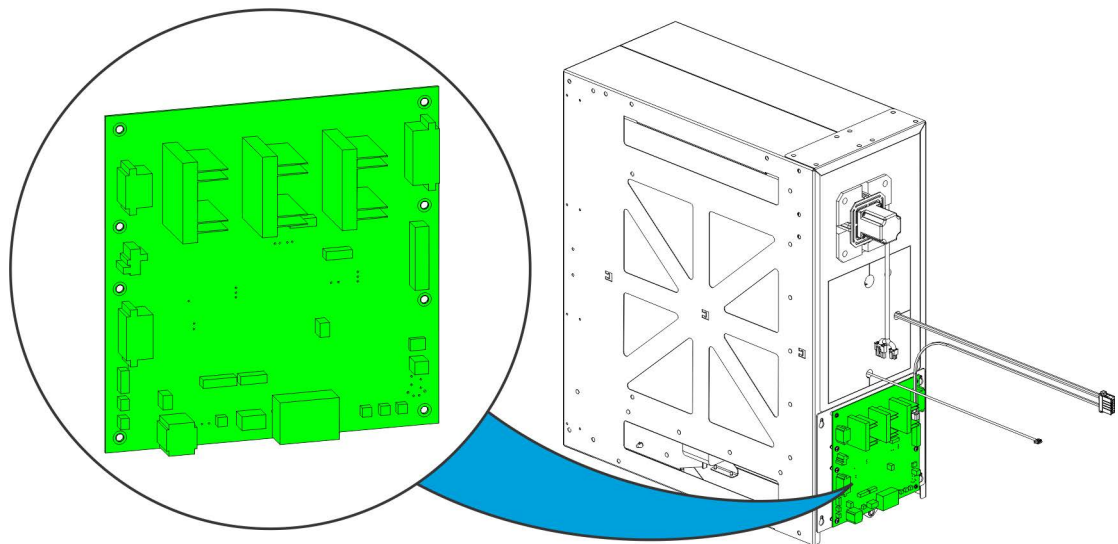
**WARNING: High Voltage**

Each of the bay climate control boards control 208 VAC power for the bay heaters. Use extreme caution while handling these components. Mishandling these components can result in injury or death.

There are four bay climate control boards, one for each material bay. The bay climate control board is located on the back of the corresponding material bay. It controls temperature inside the material bay as well as the bay blower motor, with RPM feedback, and bay heaters. The heaters are powered by 208 VAC. This is the same hardware as the oven assemblies but with unique firmware to control the dryers.

These TCBs also control the upper bay fans, located in the roof, as well as the spool bay drive motor by using encoder feedback, and the two filament switches.

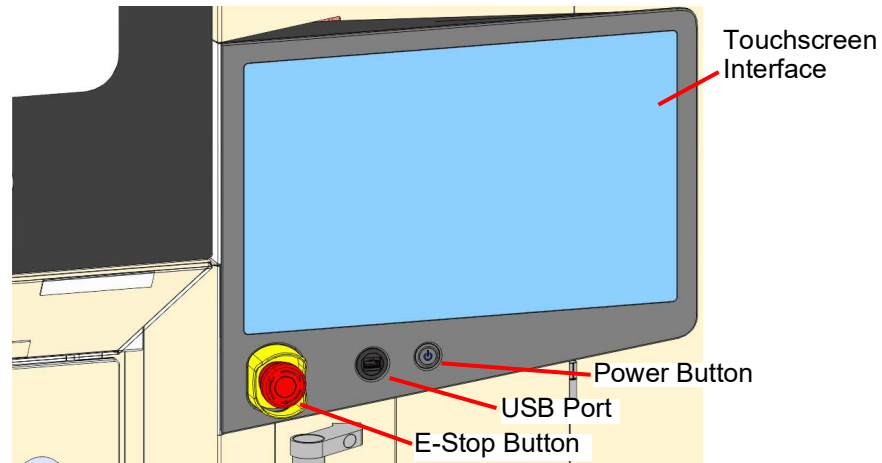
Figure 28: Bay Climate Control Board Location



Front Interface Board

This front interface board is located within the touchscreen interface panel. The Front Interface board directs the input and outputs from the power button, touch screen, LED lights, and the printer's two USB ports to and from the I/O board.

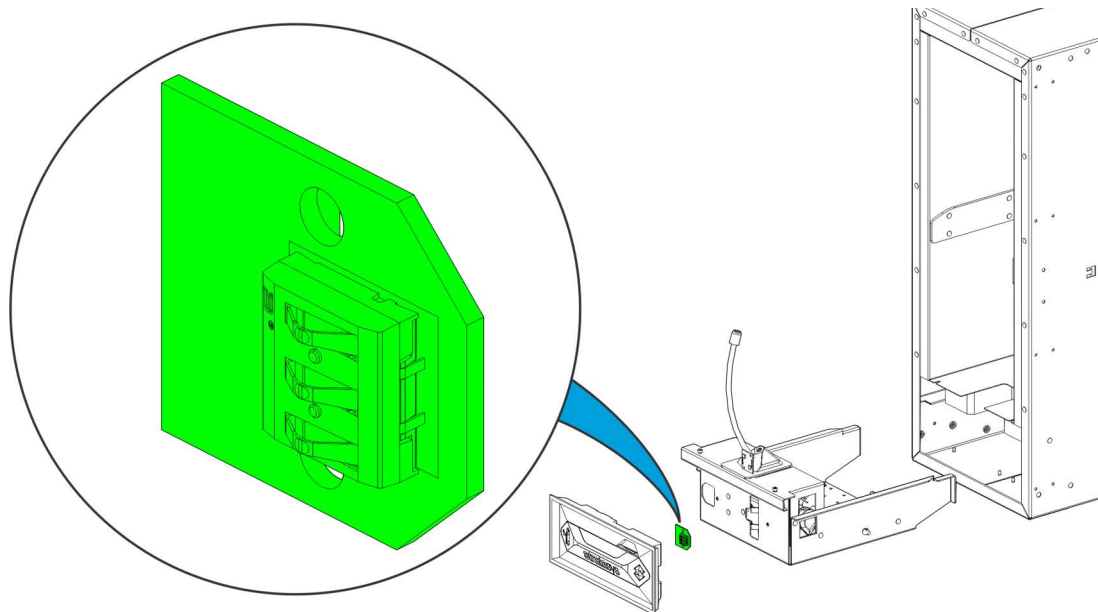
Figure 29: Front Interface Board Location



Material Bay ID Boards

There are four Material Bay ID boards, one for each material bay. The Material Bay ID boards are located at the front of each material bay inside the material drive assembly. This CCA serves as the interface point for the filament spool interface board.

Figure 30: Material Bay Reader Board Location



Filament Spool Interface Boards

The Filament Spool Interface board serves as the interface point between the Material ID CCA and the Climate Control Board (Dryer Bay). The Filament Spool Interface Board is located on the Spool handle which is tethered to the spool, and its primary functions are:

Providing electrical contact for serial bus to material ID

Providing spool present pin to Climate Control Board (Dryer Bay).

The material ID chip provides information such as:

- Material type
- Manufacturing date and lot number
- Serial number
- Material odometer

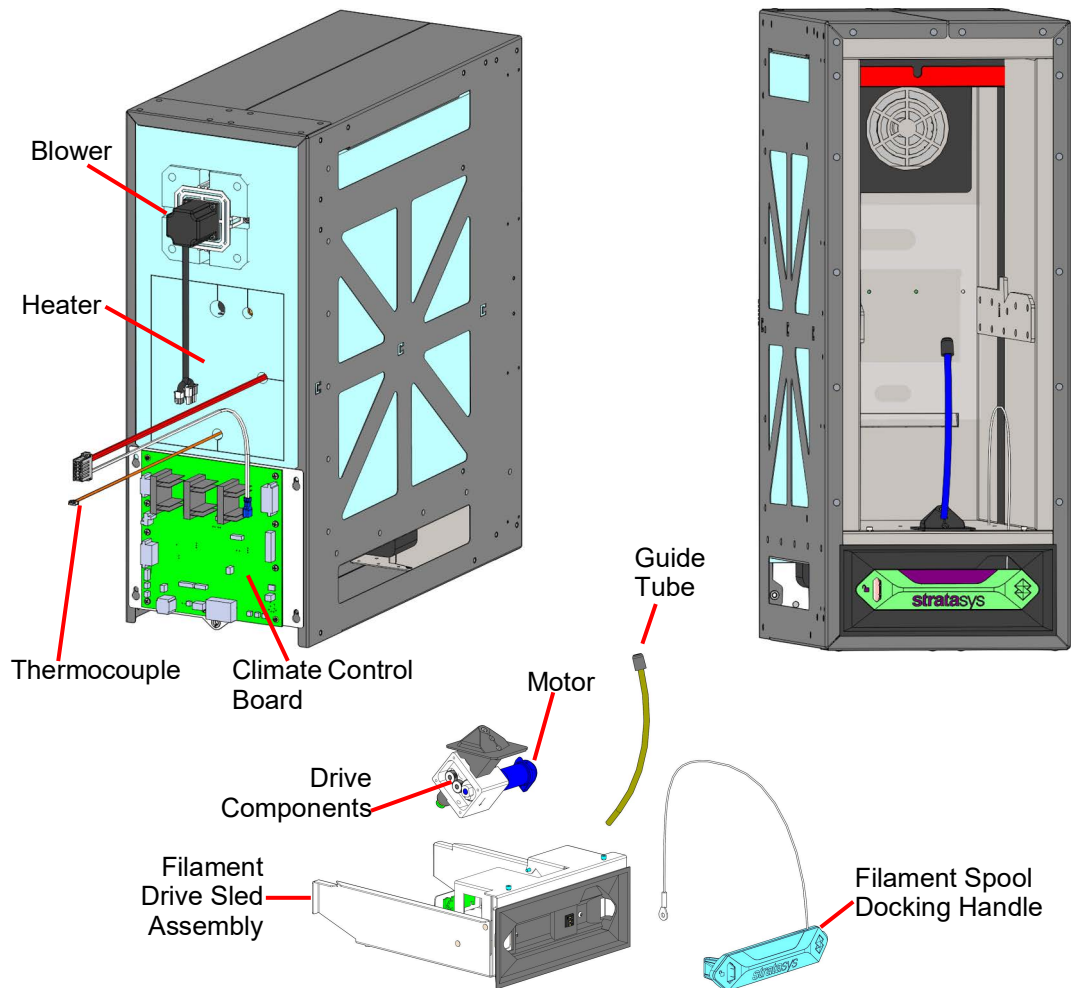
Material Delivery

Material Bays

The material bay houses a spool of model or support filament with a corresponding material ID chip. The material spool must be manually loaded to one of the material bays. The spool interface board interfaces with the material bay reader board in the filament drive bay to communicate the material type and the quantity of material remaining in the spool. The F3300 printer has four separate material bays, each capable of accepting model or support material.

The material bays are heated to maintain an optimum filament dryness. After the material spool handle is installed, the material bay temperature is set according to material type. The twin tower dryer provides dry air to each of the four bays, which along with the material bay temperature control, maintains filament dryness.

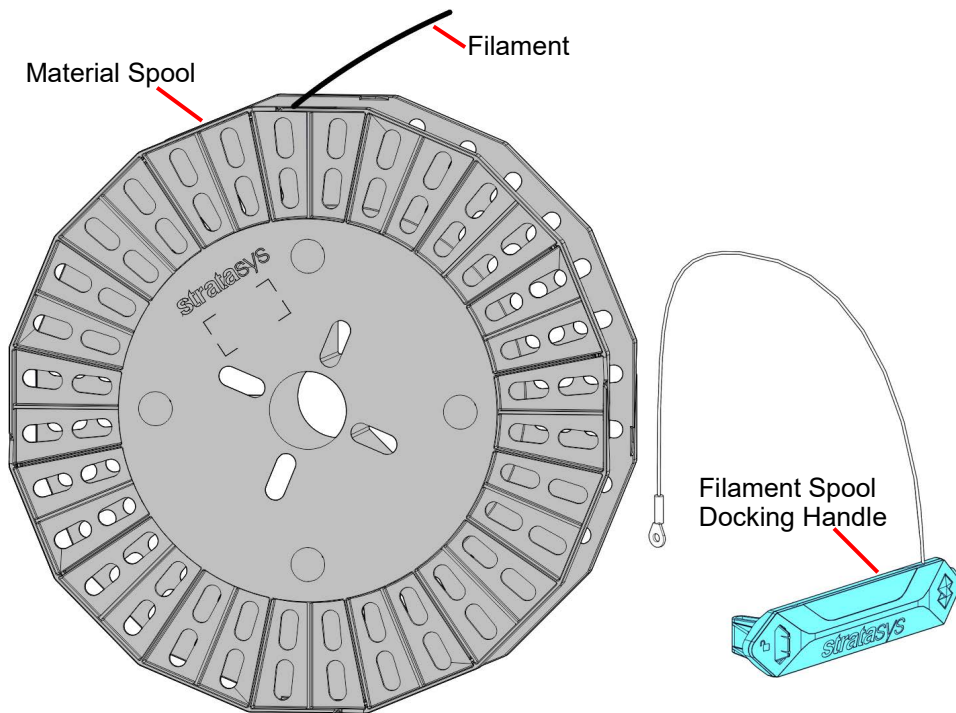
Figure 31: Filament Drive Bay



Material Spools

The material spool has the capacity to hold 4100 cc of model or support filament. It includes a molded docking handle that contains a corresponding material ID chip. The docking handle is tethered to the spool hub and can be used to transport the spool. It also interfaces with the material drive assembly when the material is loaded.

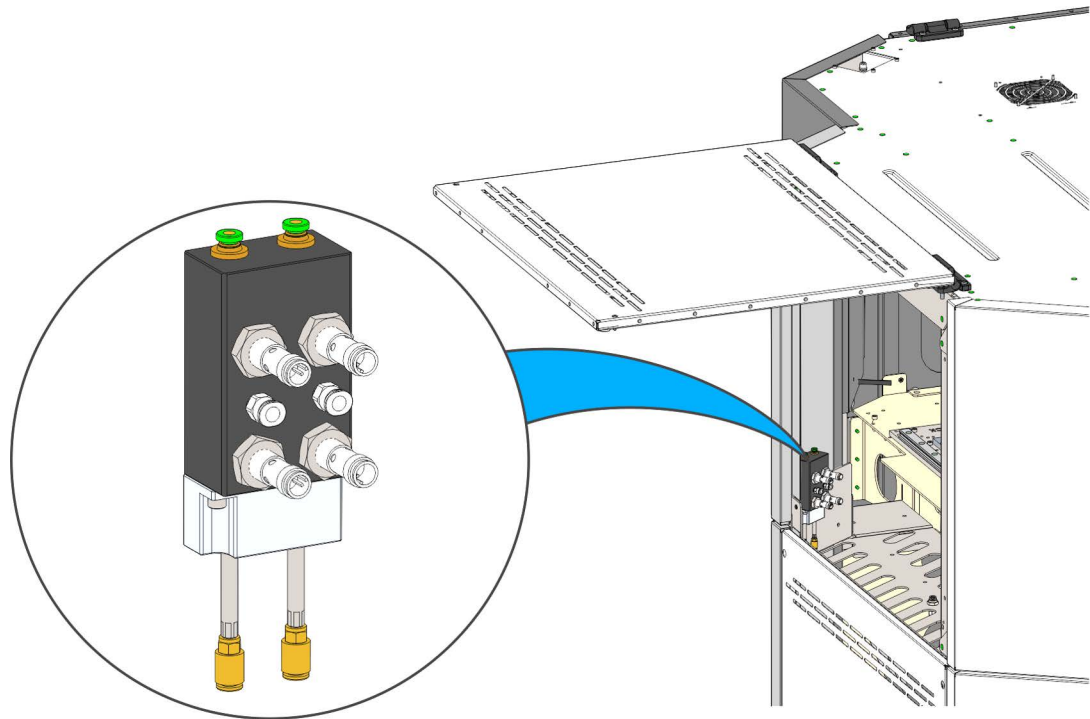
Figure 32: Material Spool



Filament Accumulators

There are two filament accumulators located in the back left and right sides of the gantry enclosure. The accumulators help manage tension in the filament path, and provide access for the dry air. The accumulators also provide a means to access the filament using the quick disconnect fittings.

Figure 33: Filament Accumulator Detail



Consumables

Table 1: Material Consumables

Material Type	Stratasys Part Number
MTRL, F3000 Series, Model, Nylon 12CF, 4100cc	363-00300
MTRL, F3000 series, Model, ULTEM 9085 RESIN (NATURAL), 4100cc	363-00400
MTRL, F3000 series, Model, ULTEM 9085 RESIN (BLACK), 4100cc	363-00450
MTRL, F3000 series, Model, ULTEM 9085 RESIN, CG (NATURAL), 4100cc	363-00450
MTRL, F3000 series, Model, ULTEM 1010 RESIN, 4100cc	363-00550
MTRL, F3000 Series, Model, PC, 4100cc	363-00200
MTRL, F3000 Series, Model, ASA (IVORY), 4100cc	363-00100
MTRL, F3000 Series, Model, ASA (RED), 4100cc	363-00105
MTRL, F3000 Series, Model, ASA (BLACK), 4100cc	363-00106
MTRL, F3000 Series, Model, ASA (LT GRAY), 4100cc	363-00107
MTRL, F3000 Series, Model, ASA (WHITE), 4100cc	363-00108
MTRL, F3000 Series, Support, SR-35, 4100cc	363-00700
MTRL, F3000 Series, Support, SR-110, 4100cc	363-00710
MTRL, F3000 Series, Support, SUP8500B, 4100cc	363-00720

Table 2: Hot Ends and Drives

Hot End and Drive Description	Stratasys Part Number
Hot End, FDM, N350	533-00350-S
Hot End (S), FDM, N410S	533-00420-S
N500 Hot End (0.25mm/0.010" Slice): Qty 1 (Model nozzle)	533-00500-S
N750 Hot End (0.50mm/0.020" slice): Qty 1 (used for model & support high flow)	533-00750-S
N410 Support Hot End (0.25mm/0.010" slice): Qty 1	533-00410-S
Hardened Hot End, FDM, N500H (0.25mm/0.010" slice): Qty 1	533-00505-S
Hardened Hot End, FDM, N750H (0.50mm/0.020" slice): Qty 1	533-00755-S
F3000 Series Extruder Drive	533-10000-S
F3300 Assembly, Head Motor	533-10010-S

Table 3: Build Sheets

Build Sheet Description	Stratasys Part Number
F3300 Build sheets, Standard ASA/PC (QTY 10)	363-30000-S
F3300 Build Sheets, Nylon material (Qty 10)	363-30100-S
F3300 Build Sheets, High Temperature (Qty 10)	363-30200-S



- Always use a new build sheet when building a job. The build sheet is intended for one-time use.
- Do not turn a build sheet over and place it on the platen. Material residue on the sheet can adhere to the platen or interfere with the build sheet vacuum.
- Using build sheets not provided by Stratasys may impact part quality and system reliability.

Table 4: Hot End and Material Life

Hot End	Model	Support	Replacement Warning Hours	Maximum Hours
N350	ASA all colors		833	1000
N500	ASA all colors		833	1000
N750	ASA all colors		833	1000
N410 Support		SR-35 4100cc	833	1000
N410S Support		SR-35 4100cc	833	1000
N750		SR-35 4100cc	833	1000
N350	ULTEM 9085		556	667
N500	ULTEM 9085/CG		556	667
N500	ULTEM 1010		556	667
N750	ULTEM 9085		490	580
N410S		SUP8500B	556	667
N750		SUP8500B	556	667
N500H	Nylon 12CF		556	667
N750H	Nylon 12CF		556	667
N410 Support		SR-110	833	1000
N750		SR-110	833	1000
N500	PC		833	1000

Hot ends are warranted for a period of 90 days from date of installation in printer, unless they meet or exceed the hours of build time expected for the material being used during the 90 days. A CFG file will be required to verify installation date.

Hot ends are designed for an expected lifespan of approximately 490 to 1,000 build hours (see [Table 4](#)). Actual performance may vary due to a number of factors, including:

- Part geometry
- Environmental conditions
- Frequency of preventative maintenance
- Frequency of material changes (which tends to have a significant impact)
- Most importantly, software must be maintained at the current release versions. Software is constantly being updated and many updates affect build performance and hot end life.


Table 5: Extruder Drive and Extruder Motor Life

Component	CC/CI Warning	CC/CI
Extruder Drive	200000 / 12185	250000 / 15231
Extruder Motor	100000 / 6092	150000 / 9139

Extruder Drive assemblies are warranted for a period of 90 days from date of installation in printer. A CFG file will be required to verify installation date.

Extruder Drive assemblies are designed for an expected lifespan of approximately 250000 CC / 15231 CI (see [Table 5](#)). Actual performance may vary due to a number of factors, including:

- Part geometry
- Environmental conditions
- Frequency of preventive maintenance
- Most importantly, software must be maintained at the current release versions. Software is constantly being updated and many updates affect build performance and extruder life.



In order to reach the max expected life of the extruder drive assembly, the Extruder motor must be replaced at 150000 CC/ 9139 CI (this is a customer replaceable consumable). The extruder motor warranty is also 90 days from installation.

Please call your regional service support center for more information as it relates to your region.

Table 6: Material and Hot End Compatibility

Model Material	Model Hot End	Support Material	Support Hot End
ASA	N350, N500, N750	SR-35	N410, N410S, N750
ULTEM 9085/CG	N350, N500, N750	SUP8500B	N410, N410S, N750
ULTEM 1010	N500	SUP8500B	N410S
Nylon 12CF	N500H, N750H	SR-110	N410, N750
PC	N500	SR-110	N410

Table 7: Build Sheet and Material Compatibility

Build Sheet	Model Materials
F3300 Build sheets, Standard ASA/PC (QTY 10) 363-30000-S	ASA, PC
F3300 Build Sheets, Nylon material (Qty 10) 363-30100-S	Nylon 12CF
F3300 Build Sheets, High Temperature (Qty 10) 363-30200-S	ULTEM 9085

Table 8: Material Bay Drying Temperatures

Material	Drying Temp °C (Initial)*	Maintain Temp °C (Secondary)*
ASA	100	55
Nylon12CF	95	55
PC	100	75
SR110	95	55
SR35	80	55
ULTEM 9085/CG	150	100
ULTEM 1010	150	80
SUP8500B	120	100

*Specified temperatures are measured at the control thermocouple. Temperatures at the spool will be 10-20°C lower.

Table 9: F3300 Drying Times

Material	Material State		
	As Received	PreDried	Saturated
ASA	100 sec	100 sec	6 hrs
Nylon12CF*	10 hrs	10 hrs	10 hrs
PC	100 sec	100 sec	4 hrs
ULTEM 9085/CG	3 hrs	100 sec	10 hrs
ULTEM 1010	100 sec	100 sec	4 hrs
SR35	100 sec	100 sec	10 hrs
SR110	100 sec	100 sec	12 hrs
SUP8500B	100 sec	100 sec	4.5 hrs

*To prevent hot end plugging, Nylon 12CF requires annealing. Dry time is 10 hours regardless of initial condition. Do not bypass.

Software

Controller Software

Controller Software is installed during the manufacturing process, and can be updated as new versions become available (see “[Calibration and Adjustments](#)” (page 196) for instructions). Controller Software is the software used to control the printer.

GrabCAD Print Software

The printer builds parts by processing an original CAD or STL file into a Stratasys CMB file which is then downloaded to the printer. GrabCAD Print is the software used to process files and then transfer them to the printer to be built. As part of the initial installation and setup process, you must download and install GrabCAD Print software. You must download this software before you will be able to build a part on the printer. Download GrabCAD Print at <https://grabcad.com/print> and follow the on-screen steps.

Jobs are sent to the printer in CMB format and placed into the Job Queue (see “[Working with the Queue Page](#)” (page 123) for information on the Job Queue.) The header of the CMB file contains the processed job’s basic information.

The GrabCAD Print Help documentation includes detailed information on how to connect to your printer, process parts, edit the Job Queue, etc. The Help file can be accessed from either the application’s Help Menu or directly from the GrabCAD website.

Insight Software

Insight is a software application used for processing STL files. Insight provides the user with the ability to utilize advanced features and manipulate numerous parameters within the file. For most applications, GrabCAD Print software will provide sufficient capabilities. Insight can be used as a standalone software, or launched as an App within GrabCAD Print. However, in some cases, the advanced capabilities of Insight may be required.

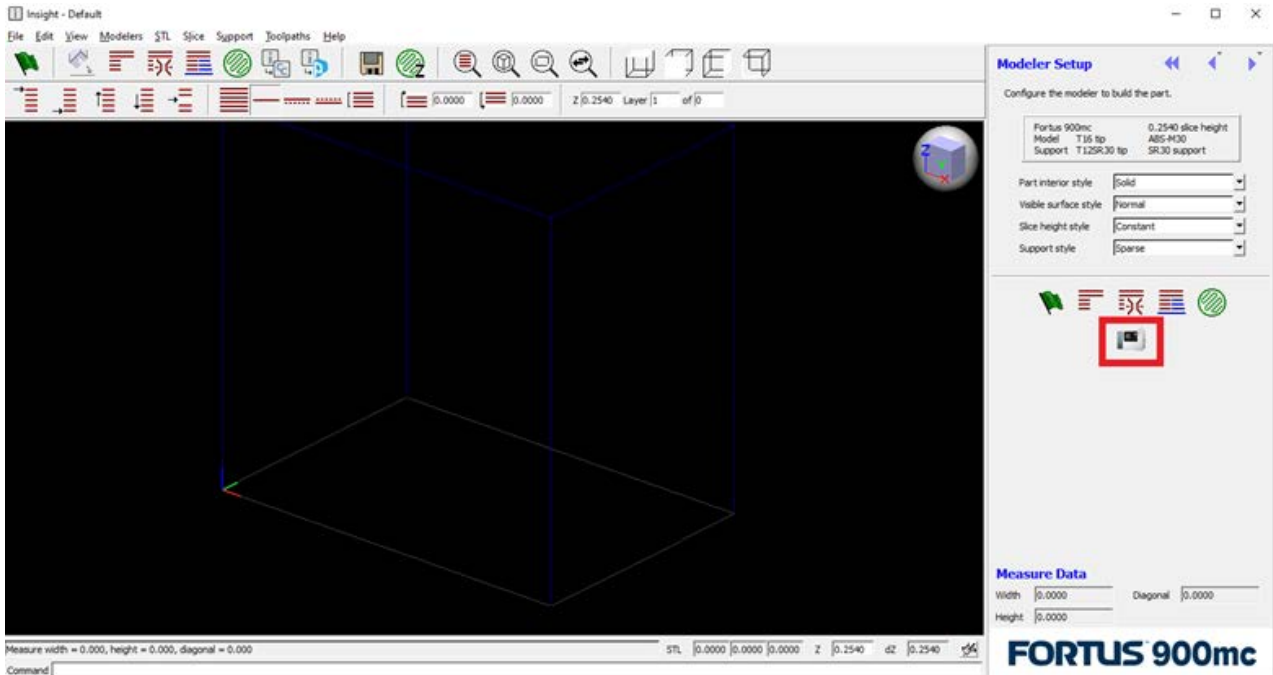
When using Insight with the F3300 printer, use the following process:



Insight will only process STL files.

1. Open Insight.
2. Select the Configure Modeler option.

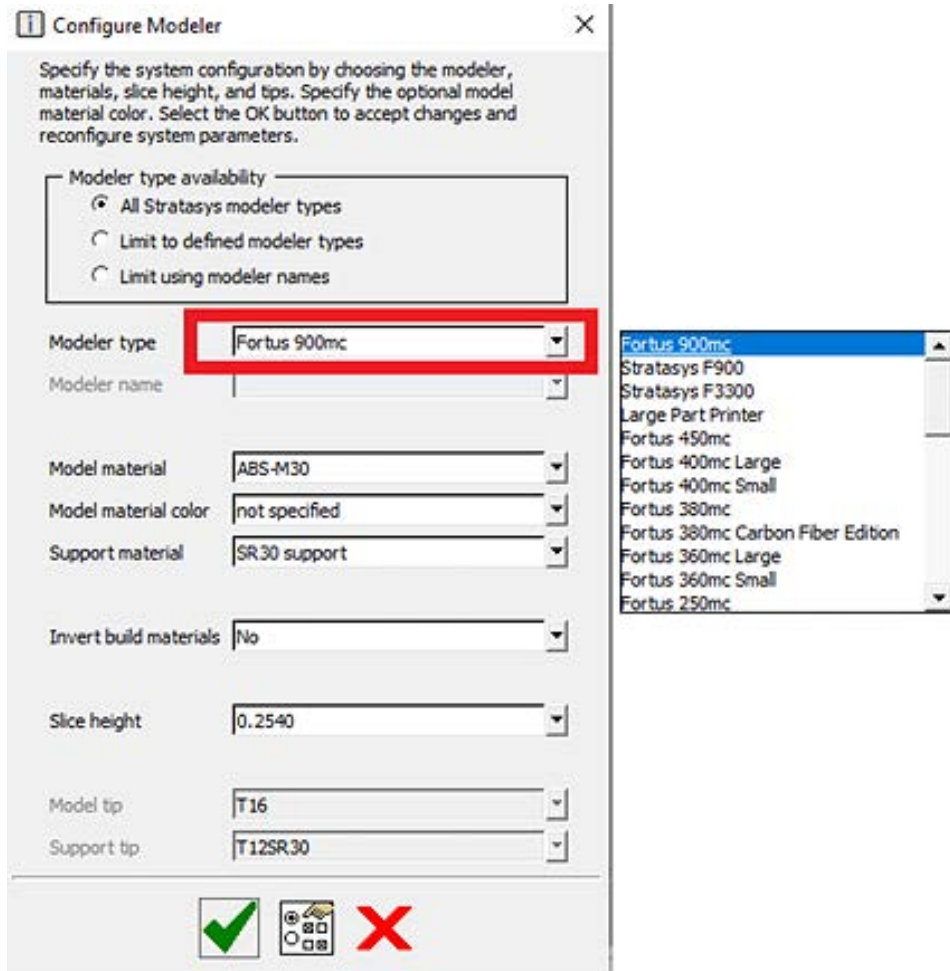
Figure 34: Configure Modeler



3. In the configure modeler dialog, select the modeler type drop down.

4. Select Stratasys F3300 from the options.

Figure 35: Select F3300



Configure Modeler [X]

Specify the system configuration by choosing the modeler, materials, slice height, and tips. Specify the optional model material color. Select the OK button to accept changes and reconfigure system parameters.

Modeler type availability

- All Stratasys modeler types
- Limit to defined modeler types
- Limit using modeler names

Modeler type: Fortus 900mc

Modeler name: []

Model material: ABS-M30

Model material color: not specified

Support material: SR30 support

Invert build materials: No

Slice height: 0.2540

Model tip: T16

Support tip: T12SR30

[OK] [Cancel] [X]

Dropdown list contents:

- Fortus 900mc
- Stratasys F900
- Stratasys F3300
- Large Part Printer
- Fortus 450mc
- Fortus 400mc Large
- Fortus 400mc Small
- Fortus 380mc
- Fortus 380mc Carbon Fiber Edition
- Fortus 360mc Large
- Fortus 360mc Small
- Fortus 250mc

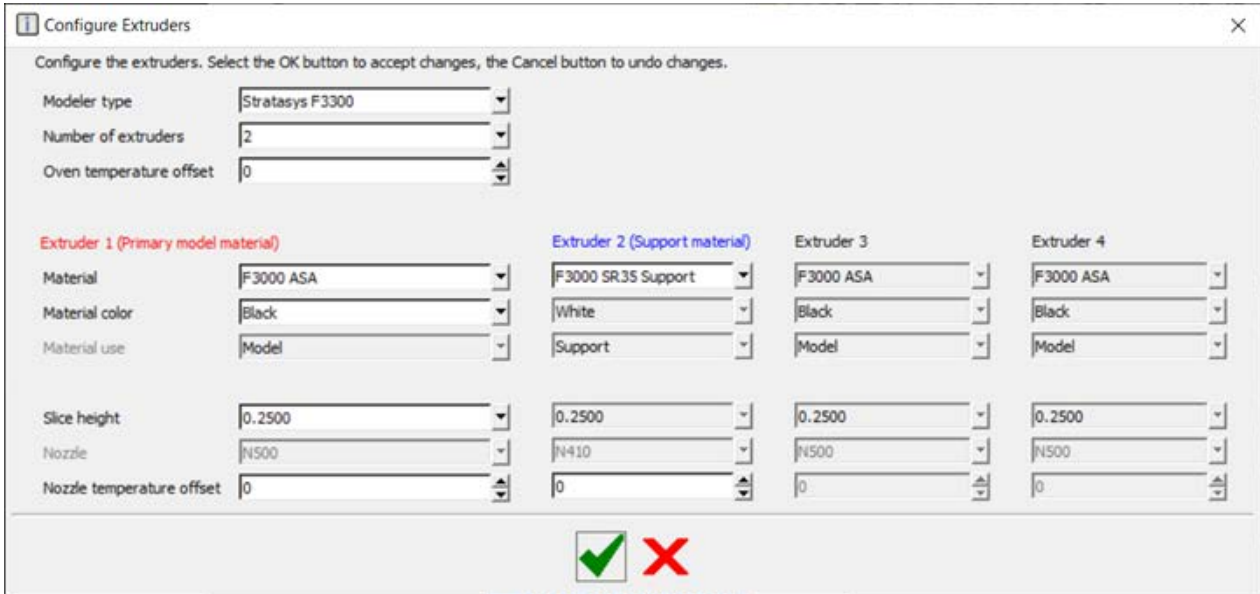
5. Select the accept check mark.

Figure 36: Select accept checkmark

6. Select the Configure Modeler option again. This will display the **F3300 Configure Extruders** options.
7. Select at least two extruders.
8. Select the model material and color. The support option is automatically populated.
9. Select the slice height that corresponds to the hot end installed in the printer. N500 is 0.250 slice height. N750 is 0.500 slice height.

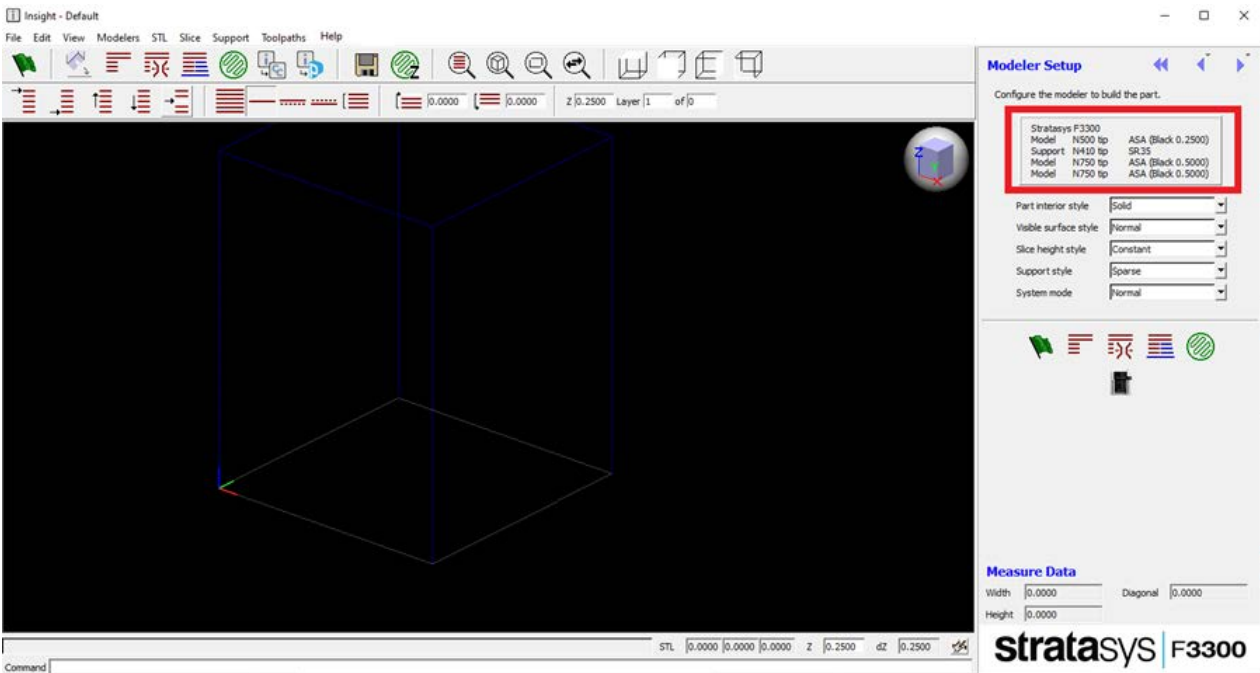
10. Select the Accept check.

Figure 37: Configure Extruders



11. The selected options display on the Insight Main Menu screen.

Figure 38: Main Menu screen



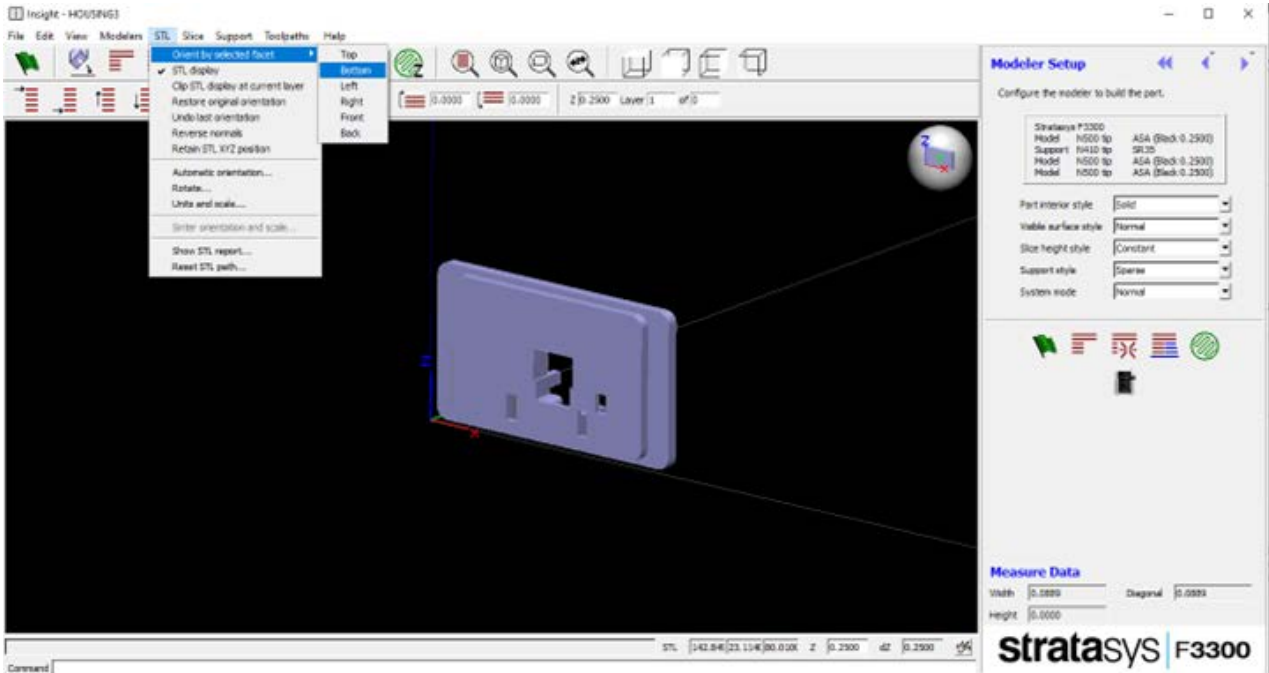
12. Select file | open.

13. Select an STL file to process. In this example, the **HOUSING3** file is selected from the **C:\Program Files\Stratasys\Insight 17.11\train** directory.

14. Select STL.

15. Orient the part by using the **Selected Facet - Bottom** screen or by using the  icon and selecting **Bottom**.

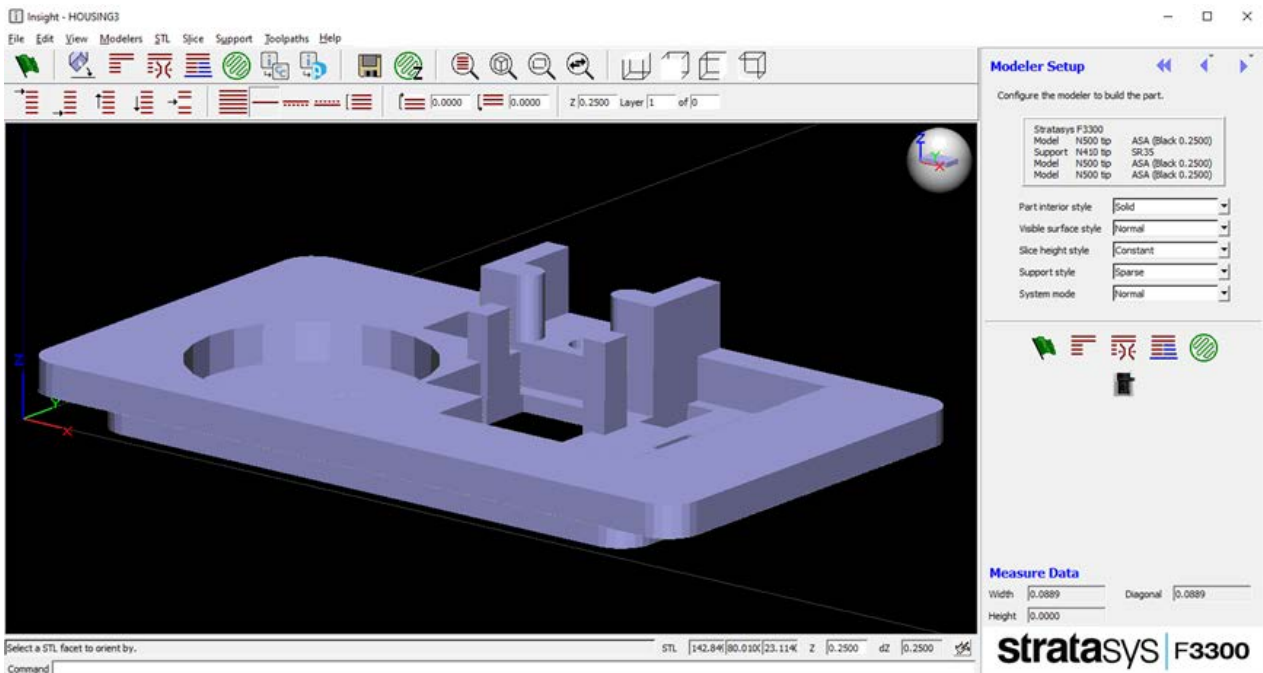
Figure 39: Orient part



16. The cursor will change to a question mark with an arrow.

17. Select the facet to orient downward on the platen. The HOUSING3 part will be rotated and placed on the platen as noted.

Figure 40: Orient downward




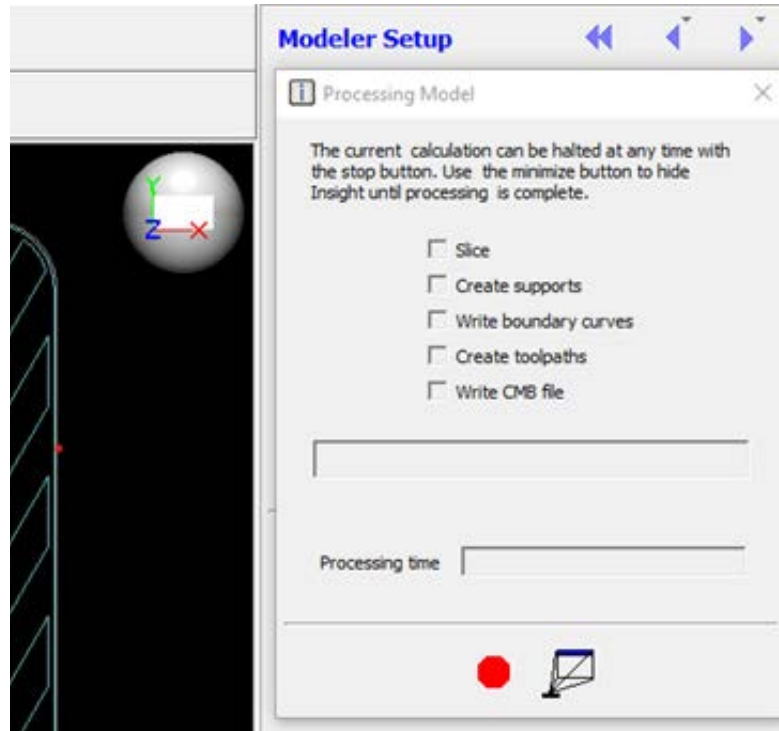

18. Process the file by selecting the green flag icon . This will slice the part, create supports, write the boundary curves, create toolpaths, and write a CMB file. If errors occur during processing, select **ok**, and press the green flag icon to reprocess the file.

Figure 41: Modeler Setup details



19. Select  top view and use the page up and down options to scroll through the file. Verify the toolpaths and supports.

- Download the file to the printer by selecting and opening **Control Center** from the **Modelers** options.

Figure 42: Control Center

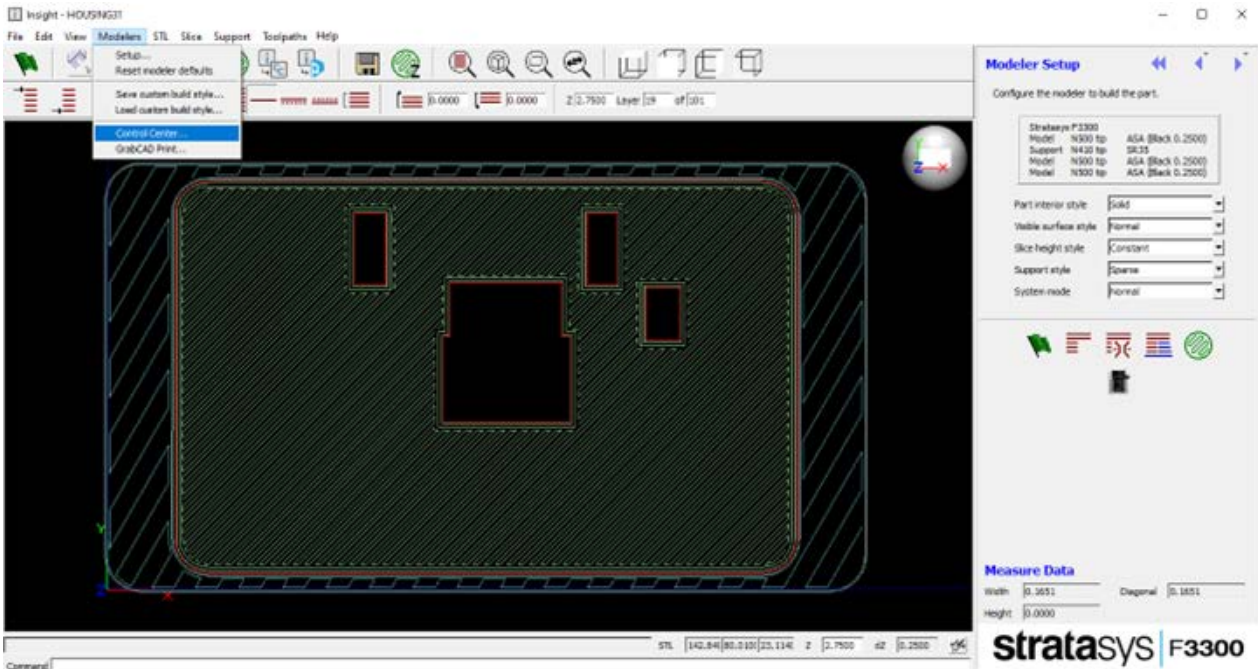
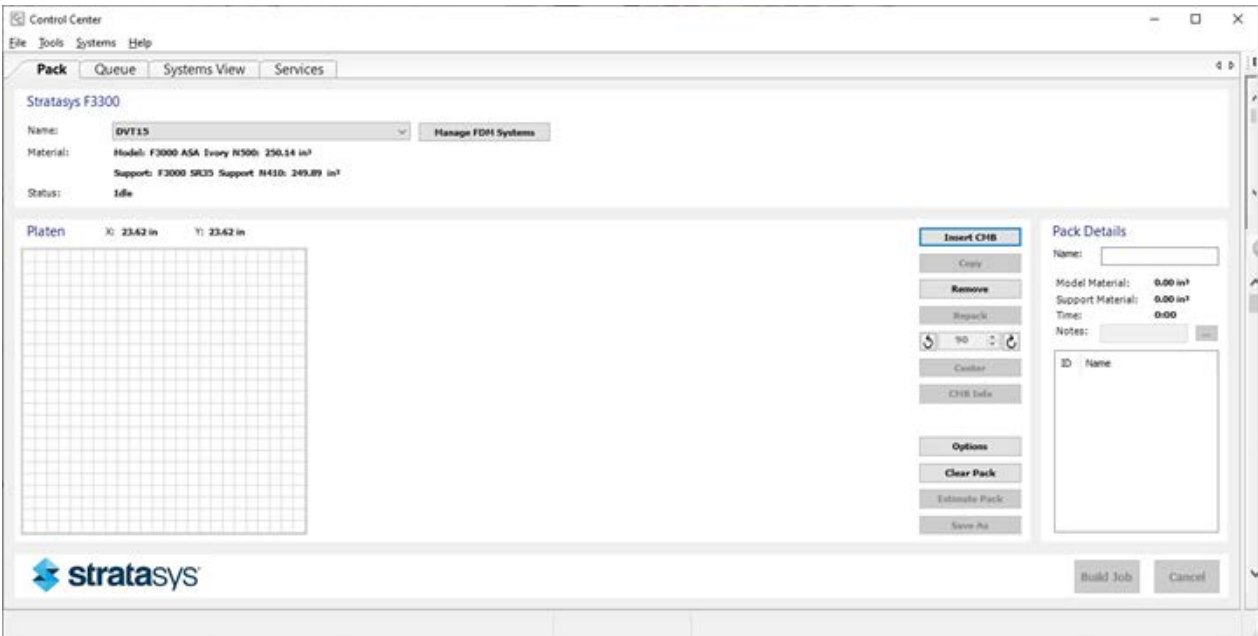


Figure 43: Insert CMB

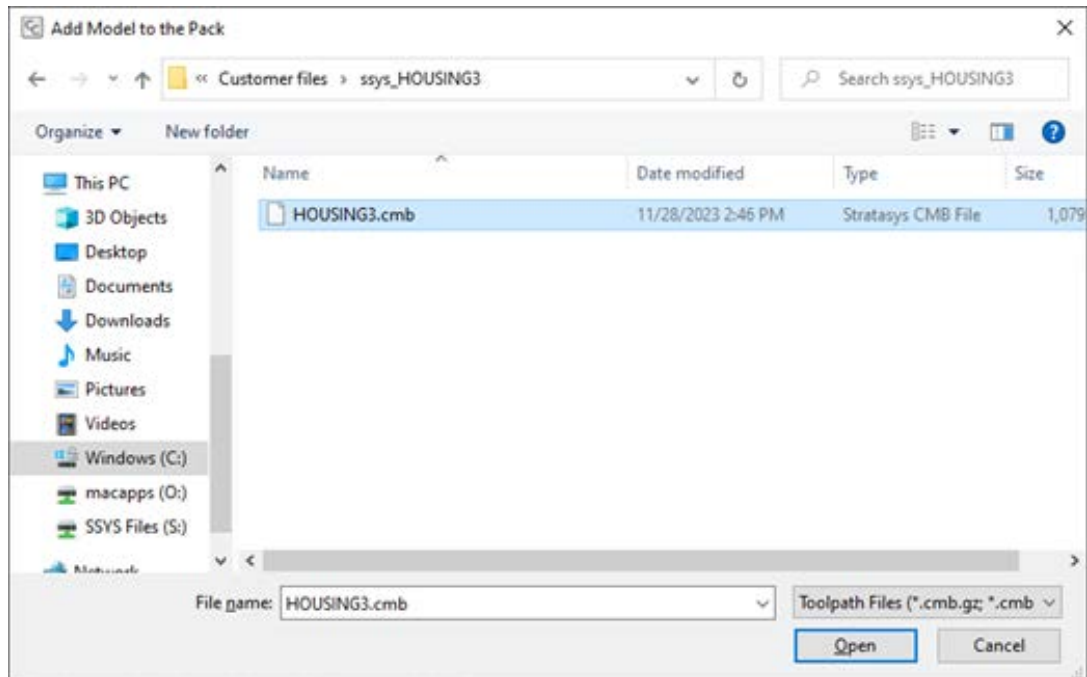




Control Center may also be started from the **Windows | Start** menu.

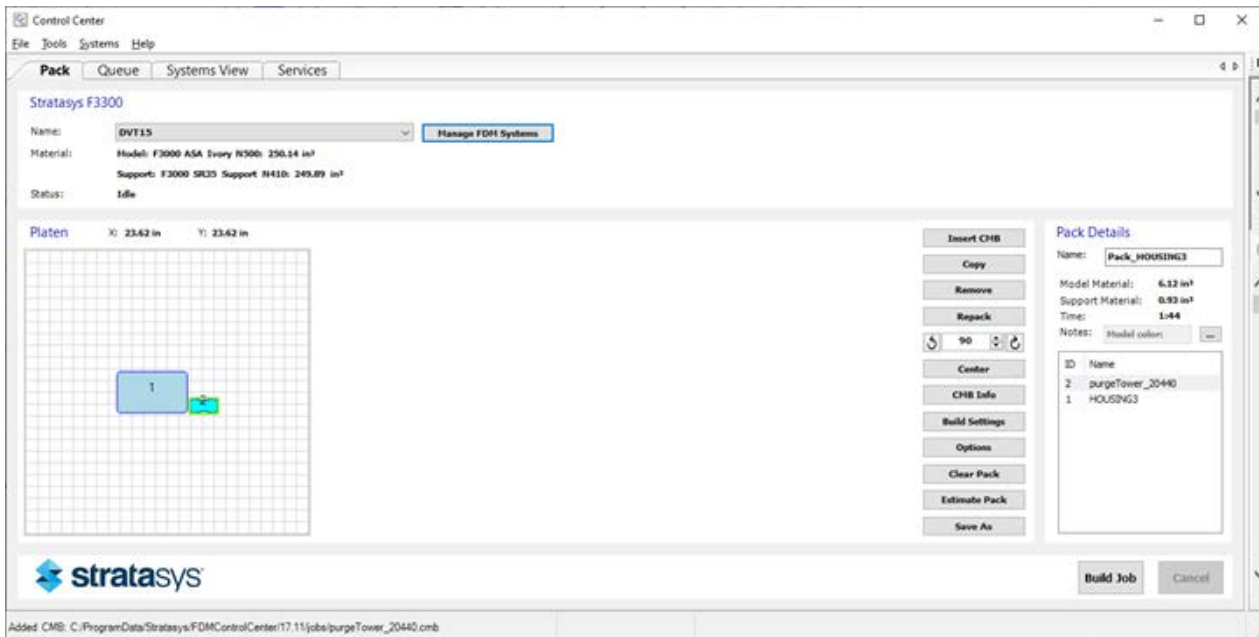
21. Select **Insert CMB**. Next, select the directory and the *.cmb file that was created above.

Figure 44: Select file



22. The processed part, along with the purge tower, will be placed in the center of the platen. Each of these may be positioned as required for the best use of the available build area.

Figure 45: Final screen



3 Safety

This chapter provides safety information and safety label locations for the F3300.

Safety Instructions




The following basic safety tips are given to ensure safe installation, operation, and maintenance of Stratasys equipment and are not to be considered as comprehensive on matters of safety. The F3300 printer is designed to be a safe and reliable rapid prototyping printer. Access to specific areas of the printer are potentially dangerous.







Product Safety Signs



Always read and adhere to safety statements, and be aware of the following safety signs when you see them on the printer.

Stratasys makes every effort to ensure that our printers are safe and reliable at all times. However, there will be times when you must access areas of the printer where potentially high voltages, hot temperatures, and/or moving mechanical components could cause severe injury.

Warning Symbols	Meaning	Location	Comments
	Hot surface	<ul style="list-style-type: none"> Material bay Hot end Bottom of oven threshold. 	Risk of burns. Do not touch this surface after printing.
	High voltage	<ul style="list-style-type: none"> On the electrical disconnect box On the power access panel Behind both top side access doors near the front of the printer 	Risk of electric shock.
	Arc flash	On the electrical disconnect box.	Energy levels may cause an arc flash. Wear appropriate personal protection equipment and follow lockout/tagout procedures.

Warning Symbols	Meaning	Location	Comments
	Moving parts	<ul style="list-style-type: none"> • Behind the front gantry hood on both ends of the extrusion tool dock • Gantry X and Y hard stops • Next to the bottom of the Local Z assembly magnetic track • On the side of the Y E-chain pan • On the back of the rear oven flange • On top of the Z stage lifting brackets 	Risk of injury from moving parts.
	Magnetic fields	Gantry X, Y, and local Z magnetic tracks.	Risk of physical injury and/or damage to magnetic storage media. Maintain safe distance.
	Gloves	Bottom of oven threshold.	Risk of burns. Wear safety gloves and sleeves approved for high temperatures.
	Confined spaces	Bottom of oven threshold.	Risk of physical injury and/or damage to the printer. Do not enter the oven with your entire body.
	Do not step	Tops of front kick panels	Risk of physical injury and/or damage to the printer. Do not step.
	Refer to manual	Next to the top front and top rear access door locking screws	Risk of physical injury and/or damage to the printer, refer to the printer manuals before accessing these areas.

Product Safety Label Locations

Figure 46: Oven threshold safety label locations

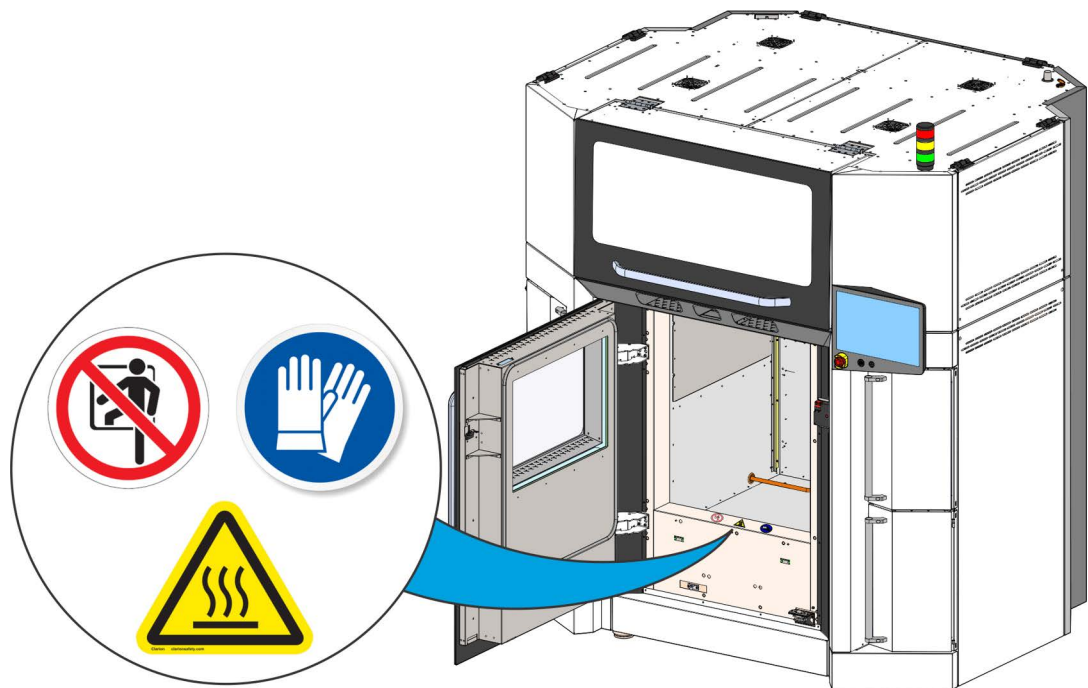


Figure 47: Top of front kick panels safety label locations

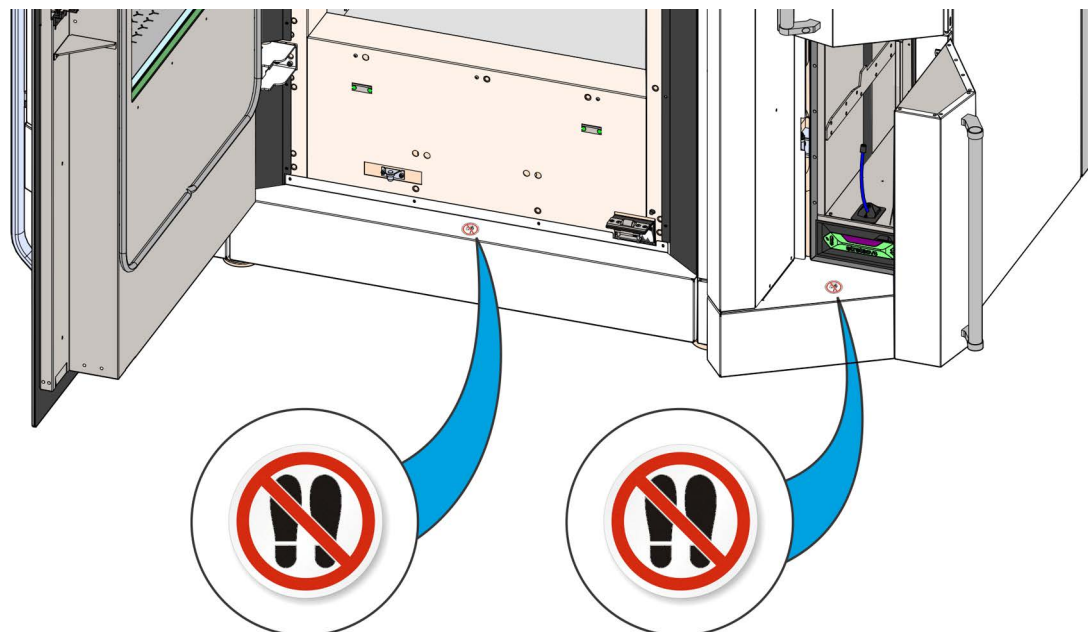


Figure 48: Filament drive bay safety labels (four locations)

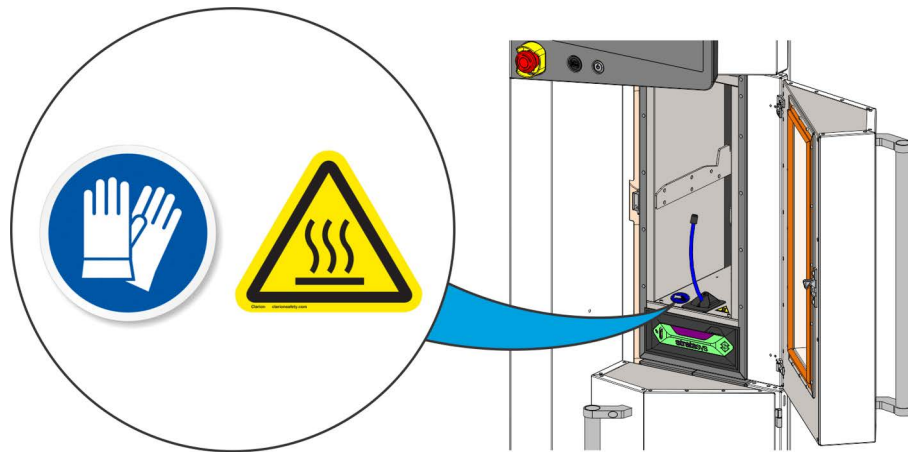


Figure 49: Electrical disconnect box safety label locations

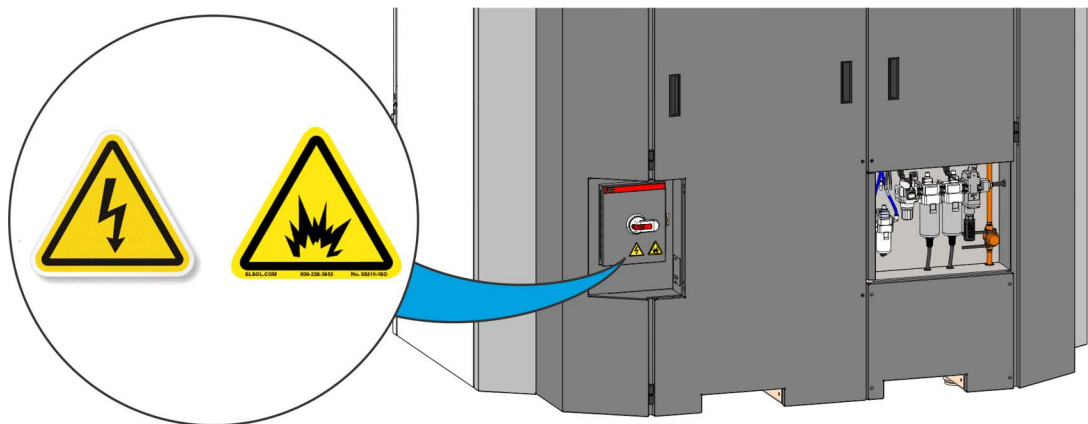


Figure 50: Power access panel safety label location

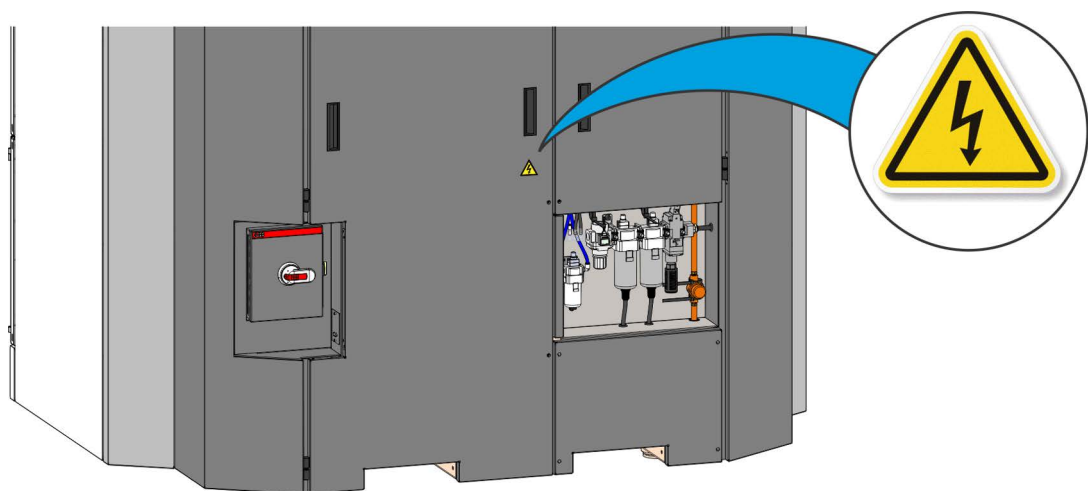


Figure 51: Side access panel safety label location (right side shown)

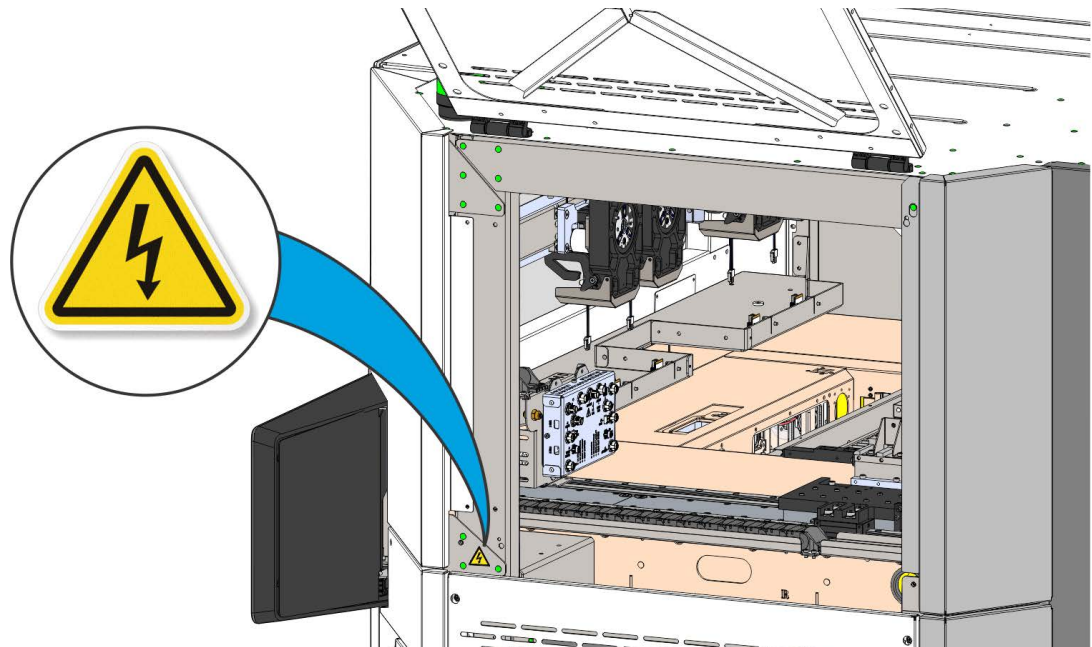


Figure 52: Front gantry hood and hot end safety label locations

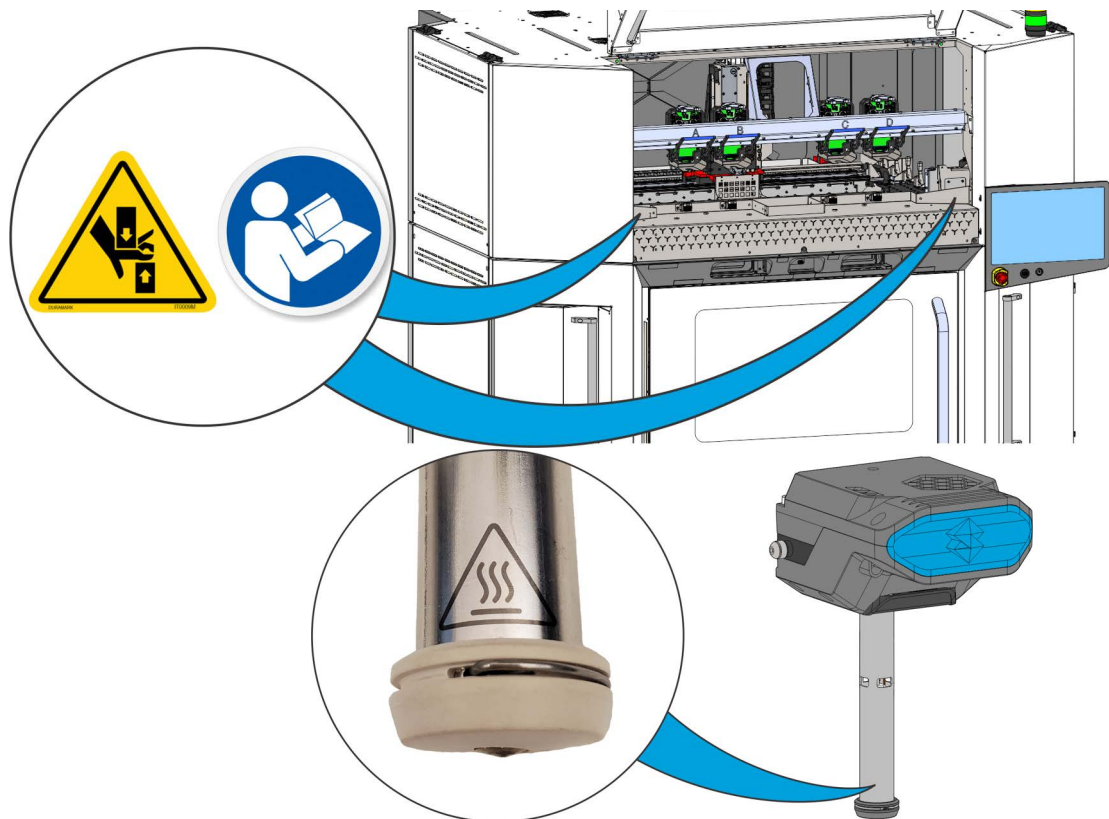


Figure 53: Gantry magnetic field safety label locations

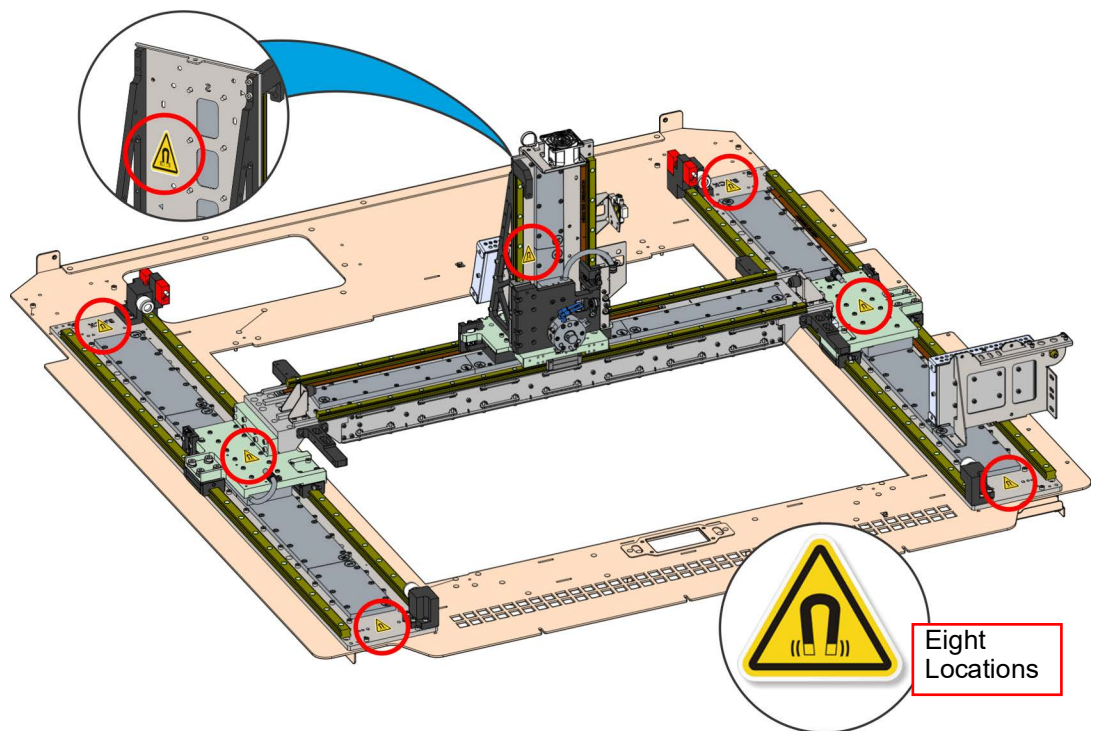


Figure 54: Z Stage lifting bracket moving part safety label locations

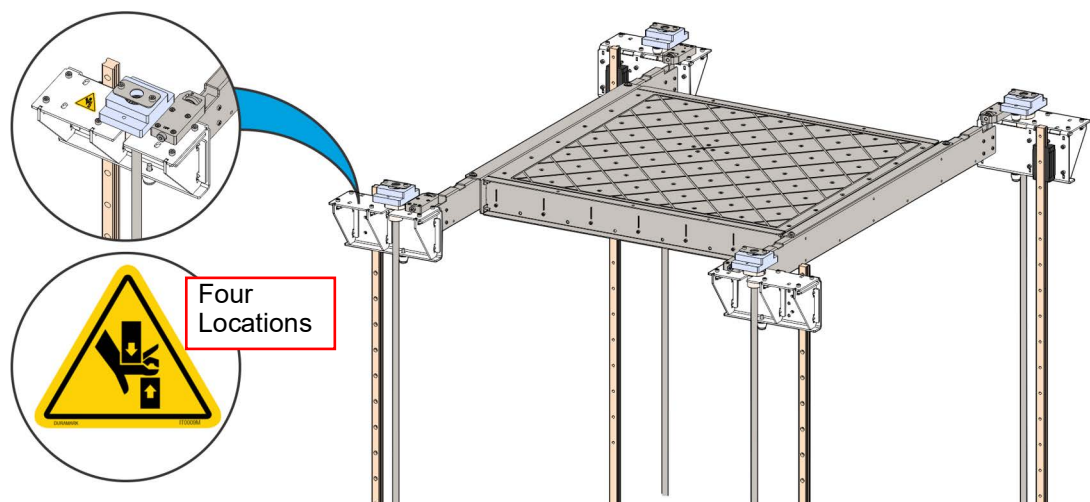
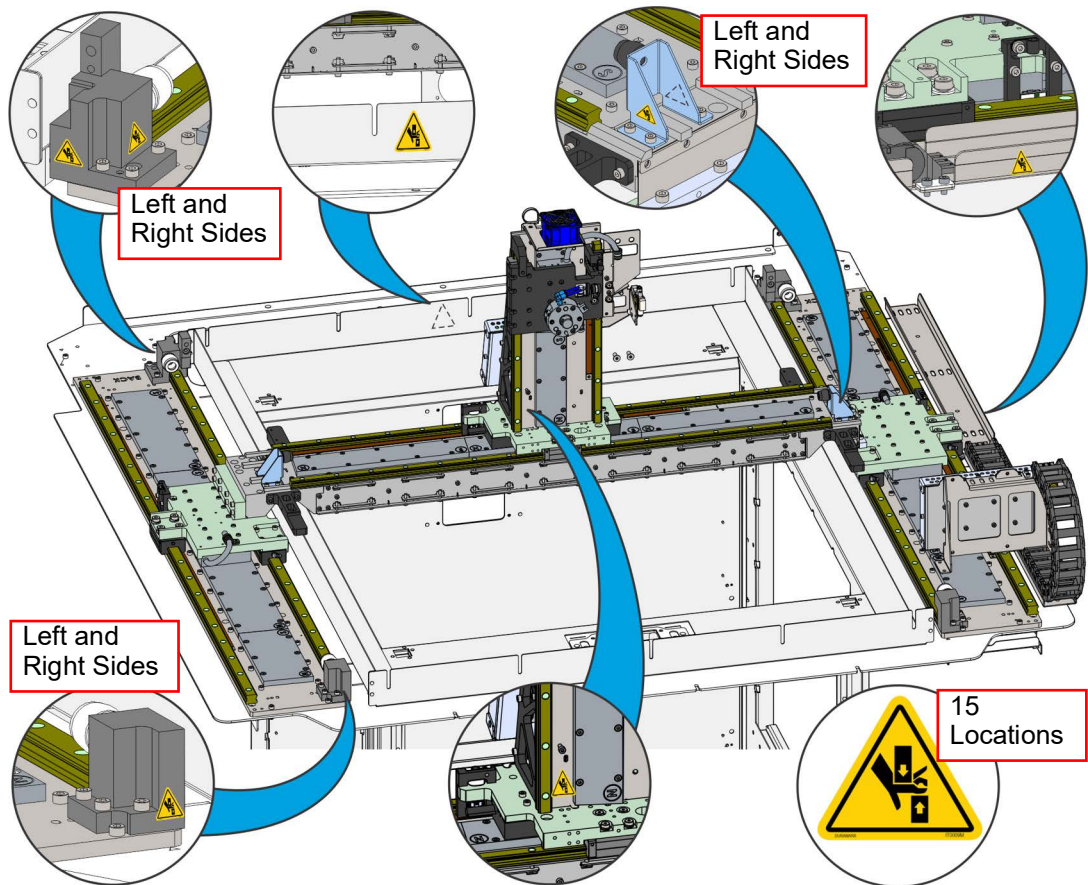


Figure 55: Gantry moving parts label locations



E-Stop

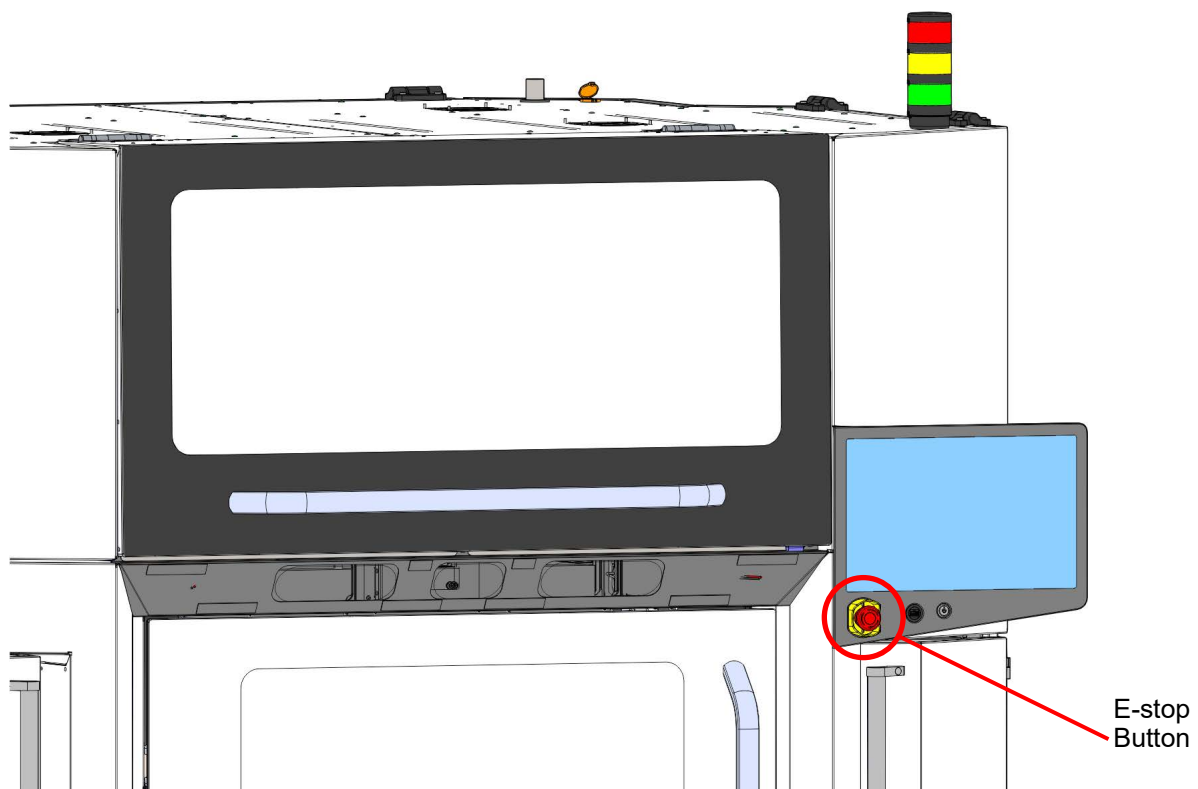
The E-stop button is located on the front right side of the printer, on the bottom of the touchscreen display. The E-stop is a safety mechanism used to disable the gantry and Z-axis motion. The E-stop does not shut down the printer or disable power to the heaters or the dryer bays.

Pressing the E-stop button inward will immediately disable motion within the printer. To reset the E-stop, twist the E-stop button clockwise. Doing so will automatically revert the button to its original position.



If the E-Stop is pressed during a build, the printer must be rebooted.

Figure 56: E-Stop Location



Potential Safety Hazard Areas

The following components and areas of the printer are highlighted as potential safety hazards that may cause system failure or reliability problems if proper safety procedures are not followed.

Oven



Warning: Hot Surfaces.

Always wear safety gloves and long sleeves when working inside the oven. Components are hot.

Gantry



Warning: Strong Magnetic Field

Strong magnetic fields around linear motor components pose a health risk to persons with implants (e.g. cardiac pacemakers) that are affected by magnetic fields. Persons with implants that are affected by magnetic fields should maintain a safe distance of at least 1m from linear motor components.

Strong magnetic forces may destroy watches and magnetizable data storage media near to the linear motor components! Do not bring watches or magnetizable data storage media into the vicinity (<300mm) of the linear motors!



Warning: Moving Parts.

Never wear a tie, loose clothing or dangling jewelry when working around moving components of the printer.

The top of the printer contains the gantry. This area houses the mechanical drive components of the X and Y axes. Use extreme caution whenever accessing this area of the printer.



The printers linear servo motors are disabled when the oven door or hood are open. Use caution while accessing the gantry area as there are pinch hazards and heated components that are accessible while the hood is open. The oven door and hood automatically lock while the printer is building and cannot be opened while building. The printer cannot start a build while the door or hood is open. Confirm the door and hood are closed before beginning a build.

Z Stage



Warning: Moving Parts.

Never wear a tie, loose clothing or dangling jewelry when working around moving components of the printer.

Oven Door and Access Door Interlocks

Interlock switches are used to communicate the status of the oven door and the hood to the printer. For safety reasons, the oven door and hood must be closed before the X, Y, and Z motors will operate.

General Safety Practices

Abide by these general safety practices when working with this printer.



Warning: High Voltage.

High voltage is present in the printer.



Warning: Falling Hazard.

Only use an OSHA or CE approved step stool when accessing the area under the top cover of the printer.



Warning: Hot Surfaces.

Always wear safety gloves and long sleeves when working inside the oven. Components are hot.

Lockout Tagout (LOTO)



Customer site procedures regarding lockout tagout always take precedence over the Stratasys service procedure.

Safe Environment

- Connect equipment to a grounded facility power source. Do not defeat or bypass the ground lead.
- Know the location of equipment branch circuit interrupters or circuit breakers and how to turn them on and off in case of emergency.
- Know the location of fire extinguishers and how to use them. Use only ABC type extinguishers on electrical fires.
- Know local procedures for first aid and emergency assistance at the customer facility.
- Use adequate lighting at the equipment.
- Maintain the recommended range of temperature and humidity in equipment area.
- Do not use this product in an environment containing volatile or flammable compounds.

Safe Human Interface

- Use proper lifting techniques when moving or installing the equipment.
- Use standard electrostatic discharge (ESD) precautions when working on or near electrical circuits.
- Do not defeat or disconnect safety interlocks.

4 Setting Up the Printer

This chapter describes basic setup of the F3300.

Maintenance Tools and Preparation

Welcome Kit

The printer's Welcome Kit (Part Number 412697-000) contains the Welcome Insert document and common tools you will need to maintain the printer. Use the following figures and tables to identify the contents of the Welcome Kit.

Figure 57: Welcome Kit Contents



Table 10: Welcome Kit List of Contents

#	Item	Description
1	25' Network Cable	A network cable is provided to connect the printer to the local area network.
2	7" Needle Nose Pliers	The pliers can be used for clearing debris which has accumulated on the Hot Ends and Extruder Drives (see also "Clean/Inspect Tip Wipe Assemblies" (page 214)).
3	5" Cutter	These are used to cut a material spool's filament when unloading and removing materials from the printer. See "Unloading Material" (page 163) .
4	Leather Gloves	Leather gloves are provided for use when removing parts from the heated chamber and can also be used when removing hot supports from a part.
5	Brush	The brush is used to remove debris from the platen to ensure proper vacuum before the start of a build.
6	4mm T-handle hex key	The 4mm T-handle is used to secure Hot Ends to Extruder Drive assemblies. It is also used to secure the assembled Extruder Drives and Hot Ends to the tool bases in the printer.
7	3/8" female coupling	The 3/8" coupling is provided to attach to the shop air hose which can then provide a quick connect/disconnect to the printer.
8	Scraper	This tool is used to scrape parts or material off the substrate.

Basic Setup

Follow the Site Preparation Guide to ensure that your facility is effectively and safely prepared for printer installation. Do not proceed with the following sections until the “Unpacking the Printer” section of the Site Preparation Guide has been completed.



If any of the tie wraps are found broken, please contact Stratasys customer support.

Stabilizing the Printer



Caution: Unstable Object

The stability pads are used to stabilize the printer after it has been moved to its desired operating location. The stability pads must be set prior to printer operation.

To stabilize the printer:

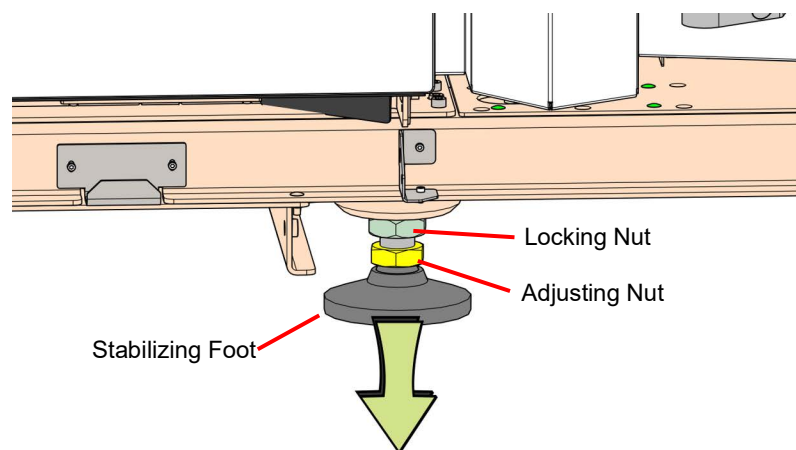
1. Move the printer to its desired operating location and verify that minimum space requirements have been met.

Table 11: Printer Clearances

Side	Clearance
Side Clearance	Minimum 36 inches (91.4 cm) on each side
Rear Clearance	Minimum 36 inches (91.4 cm)
Front Clearance	Minimum 50 inches (127 cm)
Overhead Clearance	Minimum 20 inches (50.8 cm)

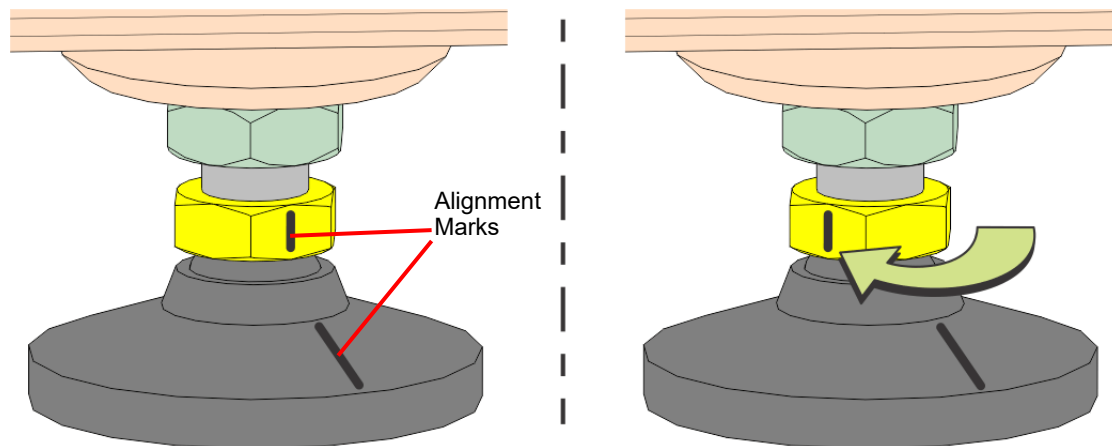
2. By hand, rotate the printer stabilizing foot clockwise until it firmly makes contact with the floor. If it is difficult to turn, verify that the locking nut is loose. Use a 35 mm wrench to loosen if necessary.

Figure 58: Lowering the Stabilizing Foot



3. While a second person pushes on the front right corner of the printer, attempt to slip a piece of paper beneath the stabilizing foot. If the paper fits beneath the foot, lower the stabilizing foot until it is no longer possible to fit the paper underneath.
4. Gently push the printer from the front and back to ensure that the printer is stable and does not sway.
5. Mark the adjusting nut and the stabilizing foot to establish a reference alignment of the stabilizing foot.
6. Using a 35 mm wrench, rotate the adjusting nut 60 degrees (the distance of one flat) clockwise.

Figure 59: Final Foot Adjustment



7. Using 10 inch channel locks, rotate the lock-nut counter-clockwise to secure the position of the foot.



If necessary, temporarily remove the front right corner foot panel and use the 35 mm wrench to access the printer stabilizing foot lock-nut.

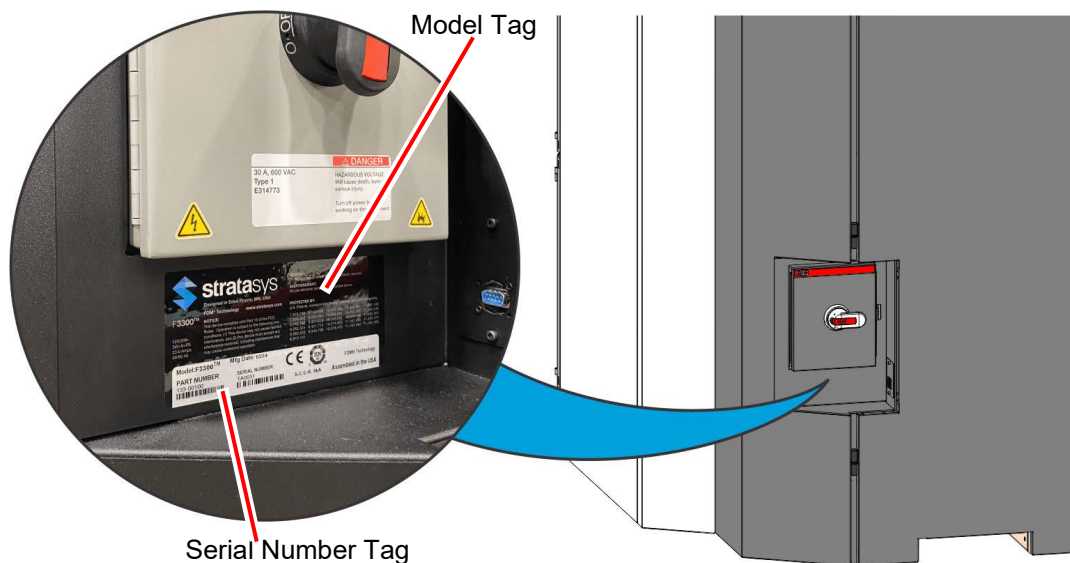
Identifying Your Printer

Use the following tags to identify your printer:

- Serial Number Tag - Refer to this number when requesting service.
- Model Tag - The printer's model number, part number and power requirements are given on this tag. This tag also lists all patent numbers associated with the printer, compliance information, voltage warnings, and the Stratasys web address.

Both tags are located on the back side of the printer near the bottom, and are typically placed near the printer's main power disconnect. Use the information on these tags when identifying your printer with Customer Support.

Figure 60: ID Tag Locations

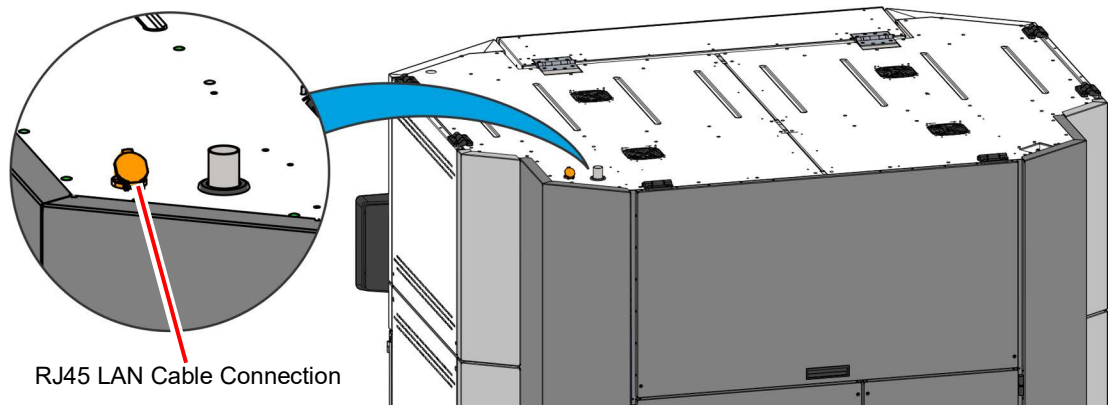


The printer model name and serial number can also be found using desktop software:

LAN Requirements

If utilizing a LAN connection for communication and file transfer functions, the LAN connection is a 100 base T, Ethernet protocol, RJ45 connector. One 7.62 m (25 foot) CAT6, 10/100 base T cable is supplied with the printer, located in the Welcome Kit. The printer will function in either DHCP or Static IP configurations.

Figure 61: LAN Connection Location



Making the Network Connection

Processed job files can be transferred from GrabCAD Print or Insight to the F3300 printer through your facility's Ethernet network. An RJ45 network connector is located on the right, rear corner of the printer (as viewed from the front). See [Figure 63](#) for the network connection location.

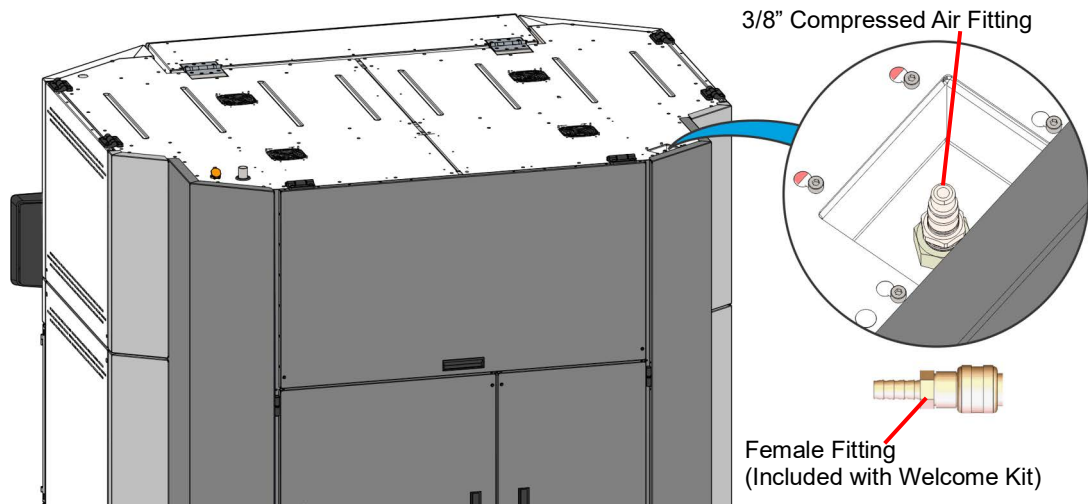
i A 7.62 m (25 foot) network patch cable is supplied with the printer and located in the welcome kit. Facilities having network connection points further from the printer than can be reached by the supplied cable are responsible for the procurement of an appropriate cable.

Compressed Air Connection

Ensure that the shop air supply is connected and that required PSI are being supplied. Verify the air pressure regulator is reading 0.65 mega pascals.

i The F3300 printer may fail to boot properly if the air supply is not connected to printer.

Figure 62: Compressed Air Connection Location



Electrical Service Connection



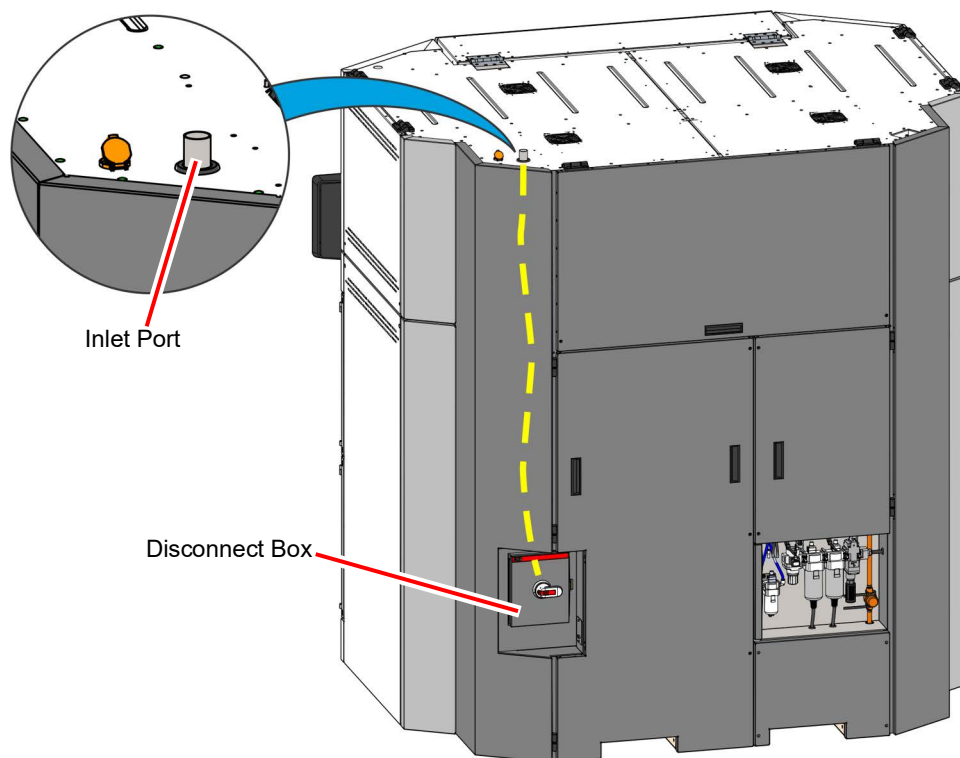
Warning: Electrical Shock Hazard.

A licensed electrician must perform all wiring from the service connection to the system - including all connectors, cables, and proper strain relief.

Confirm that the wear resistant collar, which is supplied to keep the power cable from being damaged by the top edge of conduit, is in place.

Comply with all applicable local and national electric codes.

Figure 63: Routing the power cable



Registering and Commissioning the Printer

Stratasys Advanced Real-Time Monitoring System (ARMS) establishes a secure, cloud-based connection for ongoing communication between Stratasys printers and Stratasys support systems. The Stratasys connected service powered by the GrabCAD IoT Platform enables increased printer uptime and productivity. Some key benefits include:

- Increased printer uptime and productivity
- Proactive service
- Faster resolution of technical issues
- Reduced operational costs

The main features are:

- **Real-time tracking:** Ongoing collection of errors and system events enabling immediate analysis.
- **Remote diagnostics:** Advanced dashboards and data processing tools provide actionable insights.
- **Proactive alerts:** Early detection of potential issues allows for timely interventions that prevent disruptions and optimize system performance.
- **Premium and custom reports:** Analytics on printer health, fleet maintenance, and more - unlocked with a Streamline Pro license.

Security concerns:

- Your printer data is encrypted, and kept in a secure, private connection
- Only machine data is collected from the printer - no CAD or printable files.
- Stratasys is committed to maintaining cloud security industry standards, as detailed in the [Security Practices at Stratasys](#) and the [GrabCAD IoT Platform Security Whitepapers](#).

To enjoy the benefits of Stratasys ARMS, you must have the GrabCAD IoT Platform. Proceed to install the required gateway through the GrabCAD Control account or contact your local support representative to facilitate installation.

Installing the GrabCAD IoT Platform

The IoT Gateway should be installed as early as possible. If any issues occur during installation, contact Stratasys support for assistance. If unable to install the gateway at the printer site, support personnel will have to register the printer through the printers graphical interface. Proactive alerts, real time tracking, and other premium customer support functions will not be available without an IoT gateway set up at printer site.



The gateway can be installed at any time, but adding the printer and connecting to it will be dependent on the printer being installed and preregistered by Stratasys support representative.

System Requirements for GrabCAD IoT Platform

An auxiliary computer is required for the GrabCAD IoT Platform connectivity gateway. This computer must have access to Internet and to the local network to which the printer is connected and it must be prepared before installation. This computer should always be online.

For computer specifications, click [here](#).

Prerequisites

- Ensure that you are able log in to GrabCAD Control as an Admin.
- If your user account is not configured as an Administrator, you will not be able to set up the gateway. Contact your regional Support center for assistance.
- Verify that the computer on which you intend to set up the gateway meets the required system and network requirements, and that you have Administrator permissions on the computer.
- If you are performing a re-installation of a Gateway, you will need to download a new installer. This ensures certificates are properly set up and registered.

Restrictive Environment

The system requirements state that the top-level domain of *.amazonaws.com must be reachable in order to install. If unsure, use the following procedure to test if AWS is accessible:

1. Go to <https://s3.us-east-1.amazonaws.com/>
 - If the link shows the EC2 webpage or shows a 403 error, AWS is accessible.
 - If the links shows any of the following, AWS access is blocked:
 - This site can't be reached"
 - DNS_PROBE_FINISHED_NXDOMAIN"
 - Connection timed out

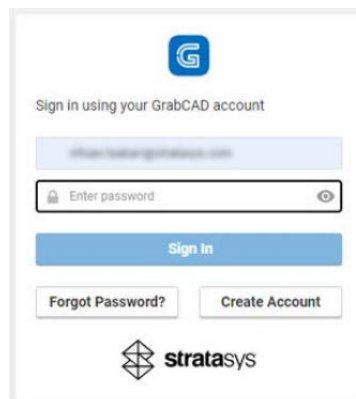


An unstable connection to the server may increase installation time.

Downloading and Installing the Gateway

1. From an Internet browser, navigate to the GrabCAD Control at <https://company.grabcad.com> and log in. To proceed, you must be an admin of a company. If prompted, select the relevant company account, then select **Control**.

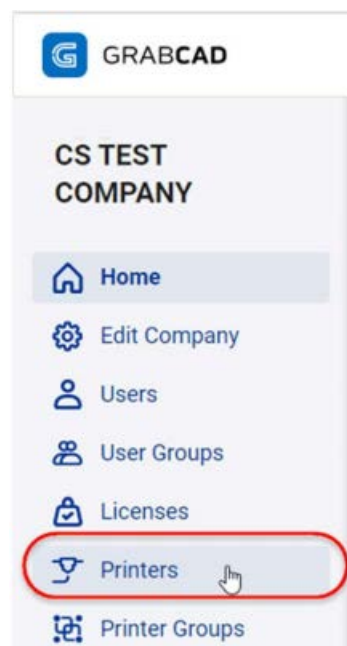
Figure 64: GrabCAD Login



2. On the left side of the screen, select **Printers**, and scroll down to the Gateways section to view existing gateways for the company account. Printers without a gateway connection may be listed here if they have already been preregistered.

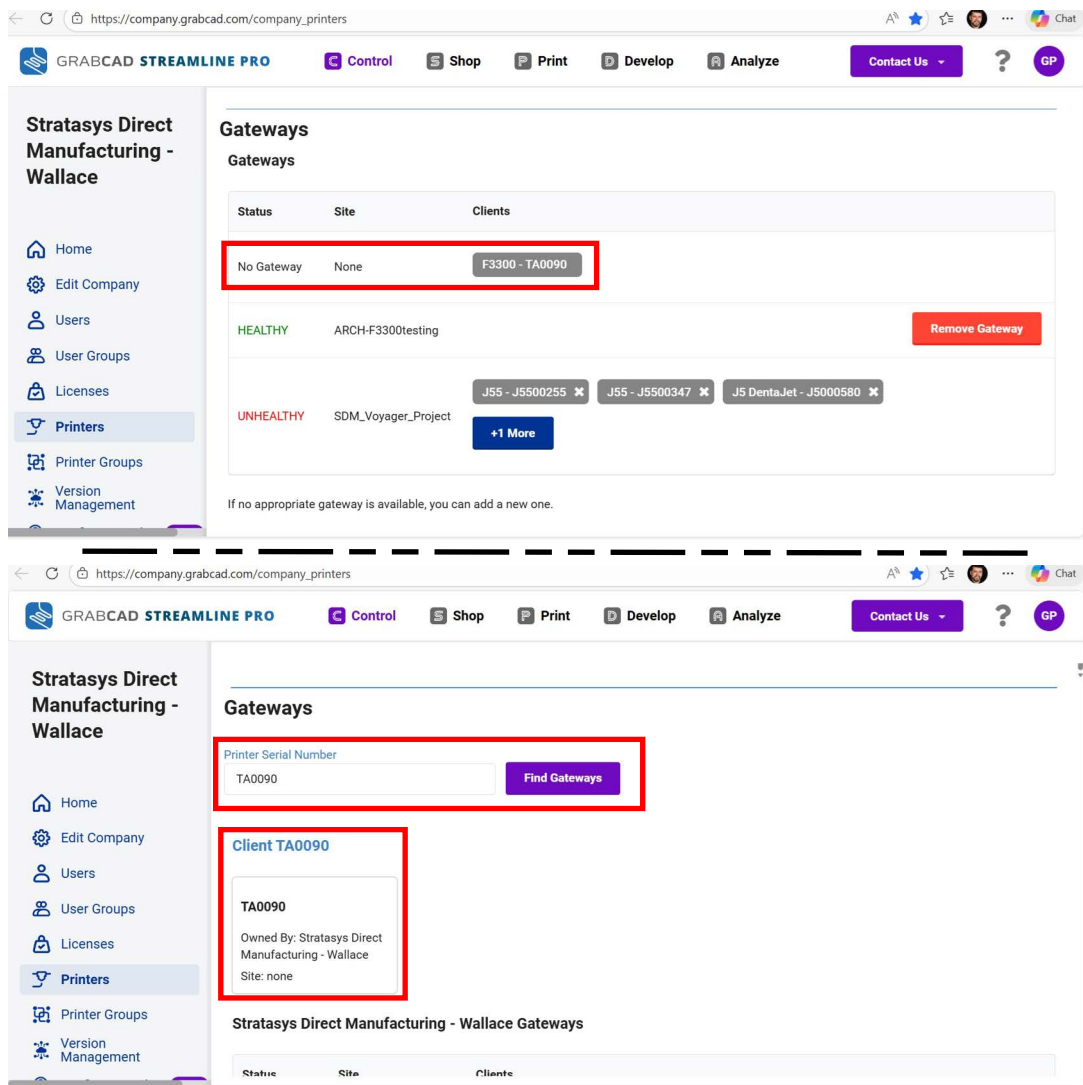
i The printer to be added must be setup on the customer network in order to be visible in the Gateway section. See [“Configuring the Network” \(page 83\)](#).

Figure 65: GrabCAD Printers



- If a gateway is already installed, it will be visible here with **Status: Healthy** and additional printers can be added to it. Proceed to [step 4](#).
- If the printer has been preregistered and displays **Status: No Gateway**, type the printer's serial number inside the **Serial Number** field and select **Find Gateways**. The **Client** and **Owned By** information will display. Proceed to [step 4](#) to commission the printer on the printers GUI which will also register the printer (this can be done by service personnel during printer installation).

Figure 66: Gateways



3. If your printer is not visible inside the Gateways screen, contact Stratasys Support. There is a pre-registration step that must be performed to associate your printer to your company account. Shipping of the printer will initiate the pre-registration process. When pre-registration is complete, perform the following steps:
 - a. Click **Add Gateway**.
 - b. When the Add Gateway screen appears, enter a name for this gateway in the **Site Name** field and select the **Region**.
 - c. Click **Create Gateway Installer** to return to the Gateways screen where a new entry for the gateway will appear.
 - d. Click **DOWNLOAD_INSTALLER** to download the dedicated unique gateway installer file that has been automatically generated.

Figure 67: Gateways, Download Installer

The screenshot shows the Stratasys Direct Manufacturing - Wallace web interface. The navigation sidebar on the left includes links for Home, Edit Company, Users, User Groups, Licenses, Printers (selected), Printer Groups, and Version Management. The main content area displays a table of gateway entries:

Status	Site	Clients
No Gateway	None	F3300 - TA0090
HEALTHY	ARCH-F3300testing	[Remove Gateway]
UNHEALTHY	SDM_Voyager_Project	J55 - J5500255 ✖ J55 - J5500347 ✖ J5 DentaJet - J5000580 ✖ [+1 More]
UNHEALTHY	ARCH-SDM	[Remove Gateway]
NEW	testing-f3300	[DOWNLOAD INSTALLER] [Remove Gateway]

- e. Run the gateway installation file.



If necessary, right-click on the file and select **Run As Administrator**.

- f. Click **Next** to proceed with the installation wizard. Do not change any of the settings until the gateway installation is complete.

- g. When gateway installation is completed successfully, the message **“Healthy”** should appear in the Status column.


 If necessary, select printers to refresh status.


Figure 68: Gateway Installation Status

Gateways


Gateways

Status	Site	Clients
HEALTHY	ARCH-F3300testing	Remove Gateway

- h. Add the printer to the gateway as described in [step 2](#). When the printer displays inside the Gateways screen, proceed to [step 4](#).

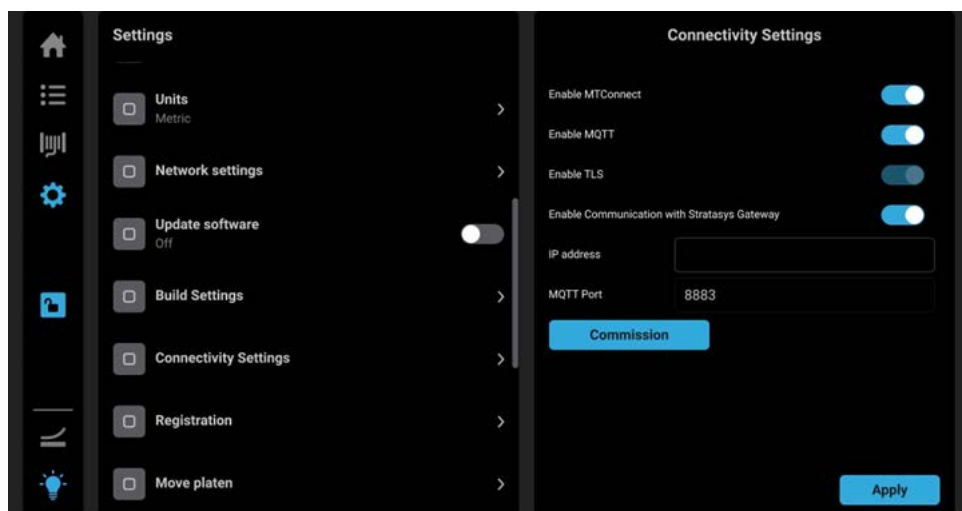
 Do not continue with the following steps until the printer has been added to the gateway.

- 4. Configure the printer gateway settings as described in the following steps:

 The following steps may be performed by service personnel during printer installation.


- a. From the Settings menu on the printer’s touchscreen, select **Connectivity Settings**.

Figure 69: Connectivity Settings



- b. From Connectivity Settings:
 - Set **Enable MQTT** to **ON**.
 - Set **Enable Communications with Stratasys Gateway** to **On**.
 - Set **Enable MTConnect** to **ON**.
- c. Enter the gateway **IP address**. The IP address must be static or reserved DHCP.

Obtain the IP address of the IoT gateway computer from site IT personnel, or open the Windows command prompt and enter “**ipconfig**” or “**hostname**” to display the current Windows IP Configuration.



```

C:\Users\adamdisanza>ipconfig

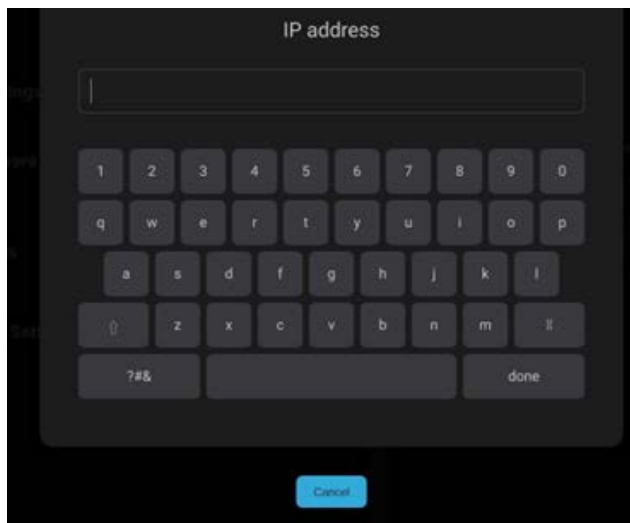
Windows IP Configuration

Ethernet adapter Ethernet:

    Connection-specific DNS Suffix  . : 
    IPv6 Address. . . . .             : fdb2:2c26:f4e4:0:2a4:3f4b:23a1:ec5
    Temporary IPv6 Address. . . . .  : fdb2:2c26:f4e4:0:8da6:e32e:6b12:eed
    Link-local IPv6 Address . . . . . : fe80::fd9e:fd3f:96e5:385d%18
    IPv4 Address. . . . .              : 192.168.88.232
    Subnet Mask . . . . .              : 255.255.255.0
    Default Gateway . . . . .          : fe80::21c:42ff:fe00:18%18
                                        192.168.88.1
  
```

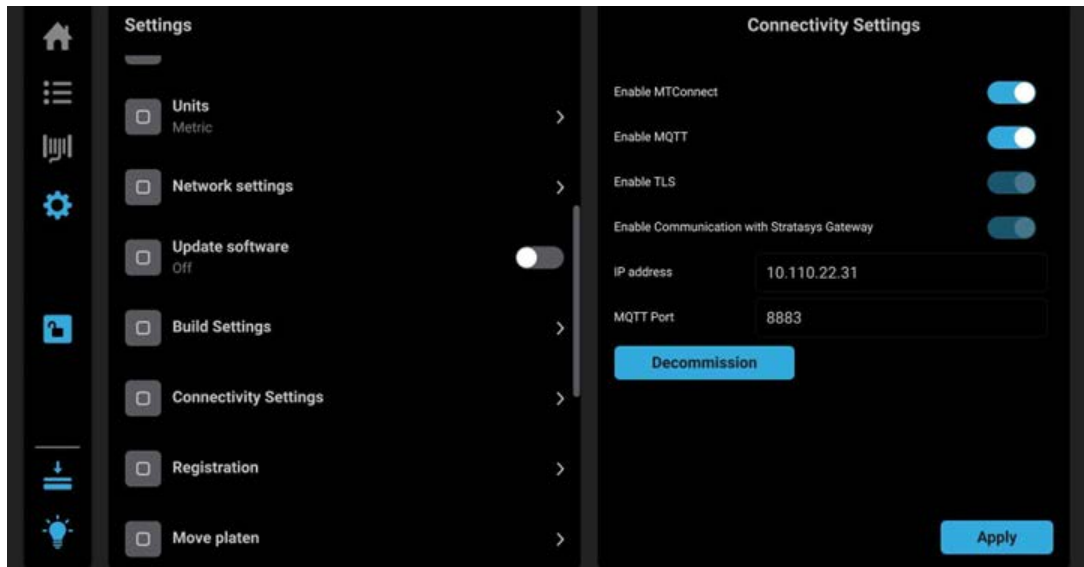
A keyboard will appear when the **IP address** field is touched. Type in the IP address and select **Done**.

Figure 70: IP Address Touchscreen Keyboard



- d. Select **Commission** to verify the selected IP configuration.

Figure 71: Settings Commissioned



- e. On the gateway computer, the Printers column should display the newly connected printer next to the appropriate gateway. The status column should continue to display **HEALTHY**. Make sure that the gateway computer remains active to ensure the best service is available for your printer.

Figure 72: Printer Connected to Gateway

Gateways

Gateways

Status	Site	Clients
HEALTHY	ARCH-F3300testing	F3300 - TA0090 ✕

i The printer will be automatically registered when connected through the gateway and will now operate normally. Unregistered printers will not allow printing of parts to start.

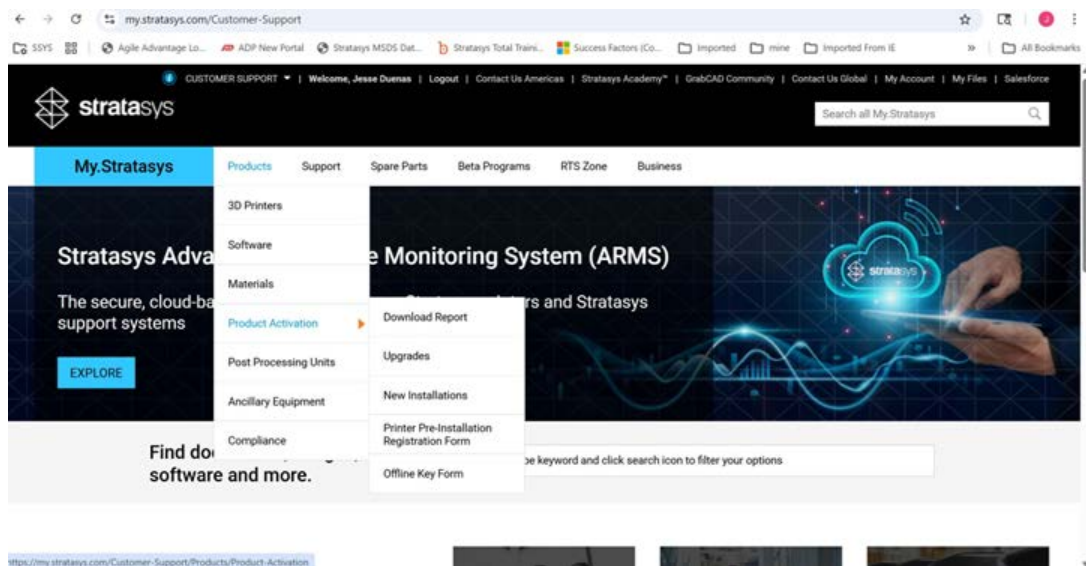
CS Service Personnel

IoT Gateway printers require pre-registration. After a customer printer ships, a notification will be sent to the FSR/CSE and/or reseller with a request to pre-register the specified printer.

Pre-Registration

1. The Printer Pre-Installation Registration Form can be located [here](#) or by navigating to [my.stratasy.com](#) > Customer Support > Products > Product Activation and Printer Pre-Installation Registration Form.

Figure 73: My.Stratasy.Com Navigation to Pre-Registration Form



2. Inside the form, enter the printer serial number and click **Search**.

Figure 74: Pre-Registration Form

Printer Pre-Installation Registration Form

Printer S/N:

Product Name:

Associated Account

Account Name:

Account Address:

End Customer Account

Keep Current Another Account

End Customer Name:

End Customer Address:

3. Verify that the populated information is accurate and select **Submit**. If incorrect information is shown here, contact the support team.

Figure 75: Populated Pre-Registration Form

Printer Pre-Installation Registration Form

Data was saved successfully

Printer S/N: J5000578

Product Name: OBJ-09250 STRATASYS J5 DENTAJET™ XL PRINTER

Associated Account

Account Name: Stratasys Inc

Account Address: 9600 W 79th St Ste 108, Eden Prairie, 55344-3737, Minnesota

End Customer Account

Keep Current Another Account

End Customer Name: Stratasys Inc

End Customer Address: 9600 W 79th St Ste 108, Eden Prairie, 55344-3737, Minnesota

End Customer Countries: United States

4. Printers connected through the gateway will automatically register once the pre-registration process is complete. For the best possible support, every effort must be made to ensure that a gateway is installed at the printer site. If a printer must remain offline, perform the following actions:
 - a. Locate and select the Product Activation - Offline Key form.

Figure 76: Offline Key Form

Offline Key Form

Printer S/N: J5000578

Product Name: OBJ-09250 STRATASYS J5 DENTAJET™ XL PRINTER

Activation Key:

Key Generation Date:

General Activation Key

Justification: This is a government site that does not allow internet access

Status:

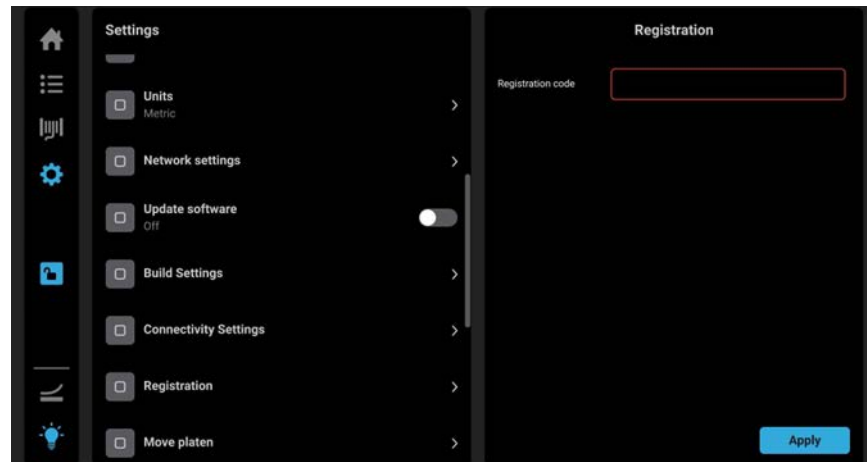
Key Justification:

Key Activation Comment:

- b. Inside the form, enter the printer serial number and click **Search**.

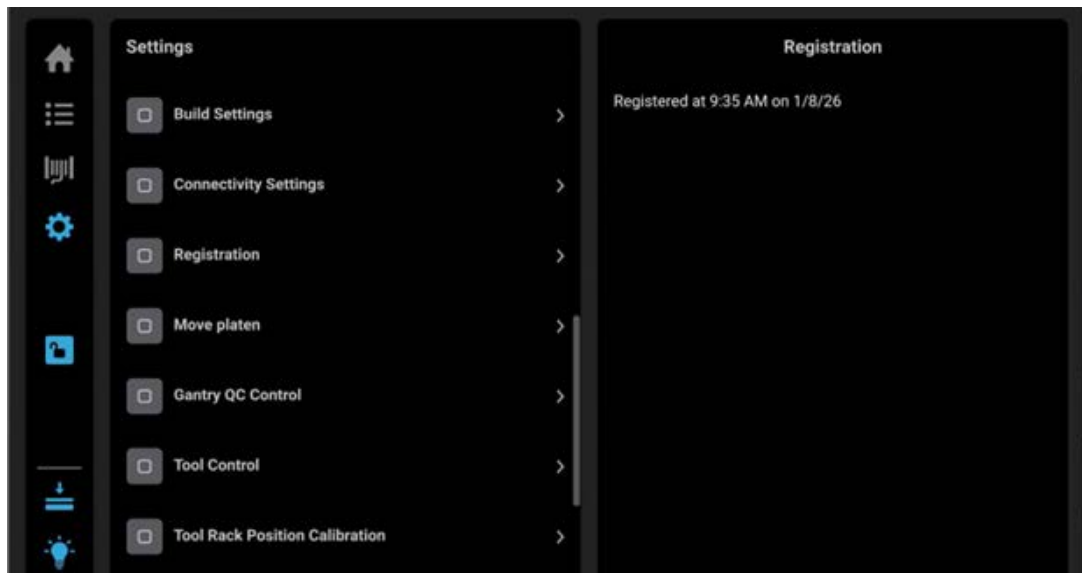
- c. Verify that the populated information is accurate and fill in the justification box describing why the IoT Gateway can not be installed.
- d. Select **Submit**.
- e. Select **OK** in the verification dialog box.
- f. When approved, an offline key will be sent to the submitter. The code/key must then be entered manually into the printer's settings menu to register the printer.

Figure 77: Settings, Registration Code Entry



- g. Enter the registration code and select **Apply**. The menu will display that the printer has been registered and printing will be allowed to proceed normally.

Figure 78: Registration Message



Configuring the Network

This section is provided in case you need to change your network settings. Within the Network page you can set your printer's address type to Static or Dynamic (DHCP); Dynamic is selected by default.

- **Static address** - you must enter an IP address, subnet mask, and gateway address for the printer (provided by the system administrator). Once entered, the address will not change.
- **Dynamic address (DHCP)** - a network server or PC will generate an IP address for the printer. A different IP address may be generated from time to time by the server or PC.

Network Address Configuration

To configure your printer's network address settings:


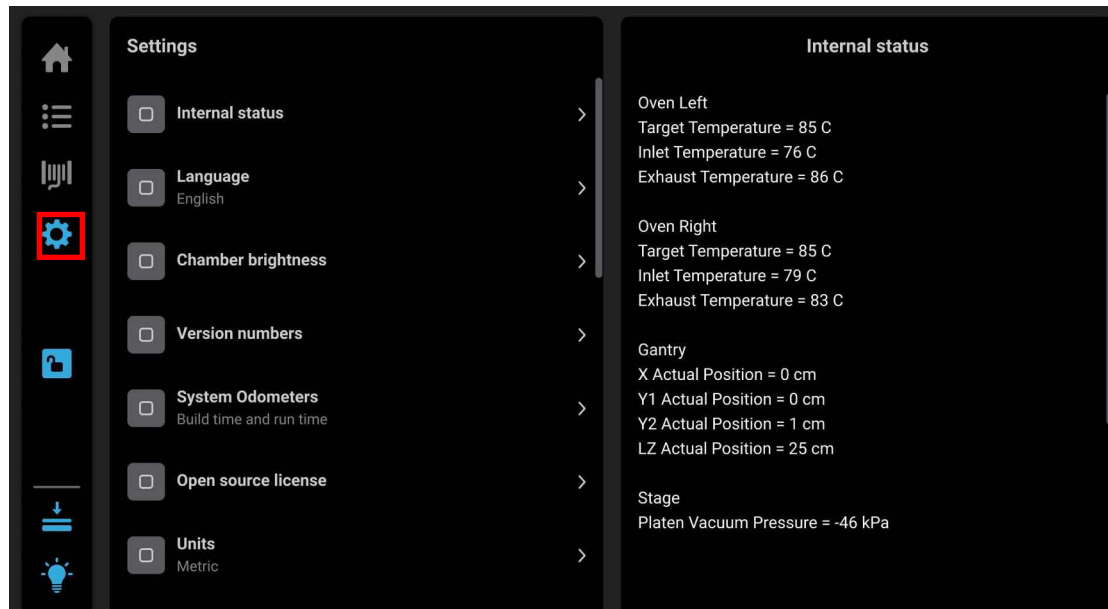
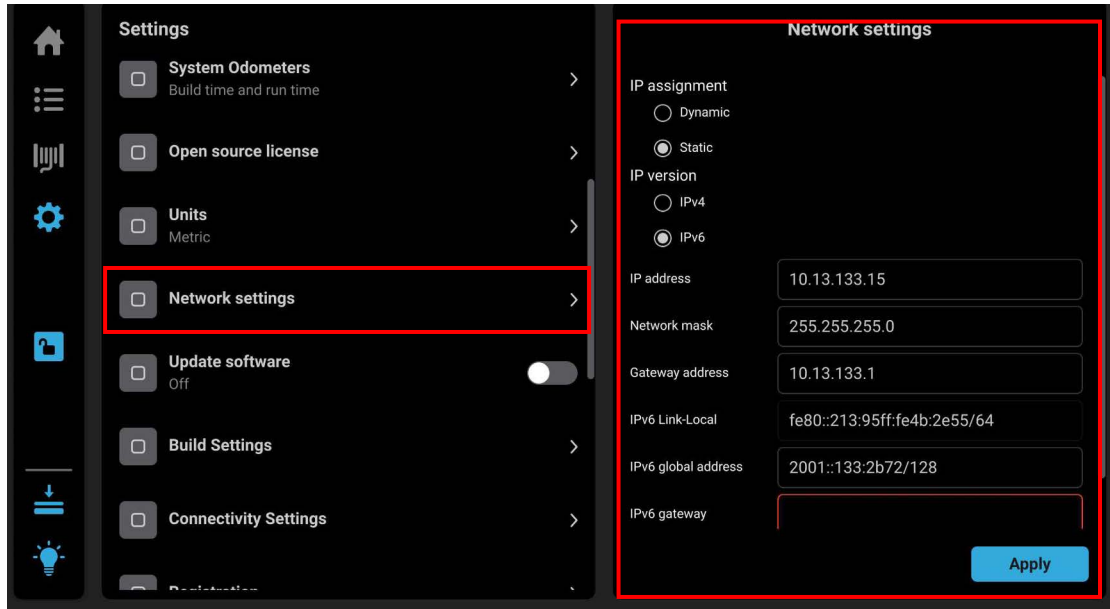
1. Click  to select the **Settings** menu.

Figure 79: Settings menu



2. Scroll down and select **Network Settings**. Next, select either the **Static** or **Dynamic** radio buttons and the **Ipv4** or **Ipv6** to enable that network address type. Depending on the option selected, you may need to configure additional information within the Network page.

Figure 80: Settings IP assignment



3. Configure the Static or Dynamic option:
 - To enable the **Static** option, enter network information in the **IP Address** field, the **Network Mask** field, and the **Gateway Address** field by pressing the field and using the keypad that displays. Exit the keypad by selecting **done** or press outside the keypad box. Select Apply.
 - To enable the **Dynamic** option, no additional configuration is necessary as a network server or PC will automatically generate an IP address for the printer. A different IP address may be generated from time to time by the server or PC; the generated IP address will be displayed within the IP Address field of the Network Settings page, and corresponding Subnet Mask and Gateway Address information will also be displayed.
4. Select **Apply** to save any changes to the Network Settings.

GrabCAD Software

GrabCAD Software is comprised of three applications:

- GrabCAD Print
- GrabCAD Print Server
- GrabCAD Streamline Pro

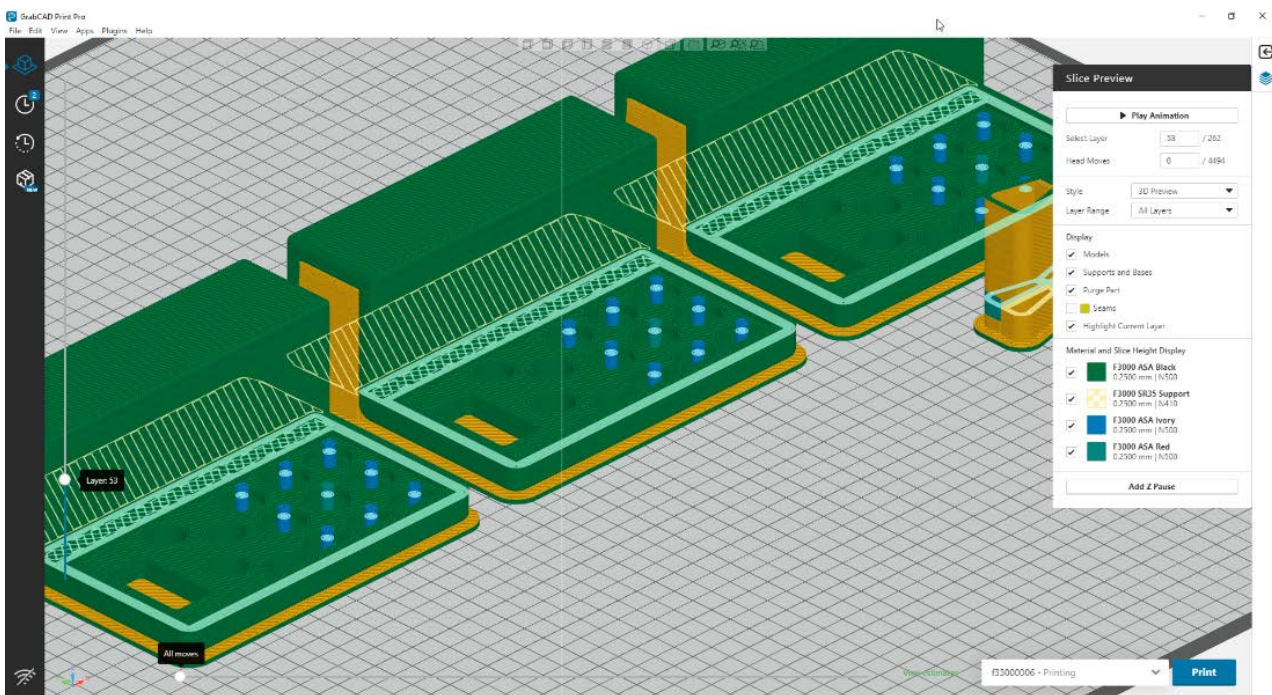
GrabCAD Print may be used on its own or with the GrabCAD Print Server, which enables remote operation. GrabCAD Streamline Pro is used to monitor printer schedules, view reports and control printer access.

GrabCAD Print

GrabCAD Print is a Windows 11 based desktop application that is used for:

- Programming print jobs and sending them to Stratasys printers.
- Monitoring printer schedules and managing printer queues.
- Relaying print job progress, relaying required setup changes, and relaying printer issues that impact print jobs.

Figure 81: GrabCAD Print Slice Preview



Installing GrabCAD Print

Download GrabCAD Print at <https://grabcad.com/print>. A user account is required to download GrabCAD Print, and administrative privilege is required for installation. Install GrabCAD Print by double-clicking the installer or using a command prompt. Use a command prompt to install GrabCAD Print for specific situations detailed below.

/offlineMode

This enables the printer to work off-line. Users do not have to sign in to GrabCAD Print. Instead of selecting printers from the company account in GrabCAD Print, printers are added by entering the printer IP addresses in the Printer Panel. Once the printers have been added in this way, GrabCAD Print can be used to select these printers, send them jobs, and monitor their schedules.

/disableAutoUpdate

This turns off automatic updates. Updates may still be downloaded in the background, but the upgrade will not happen until confirmed by a user.

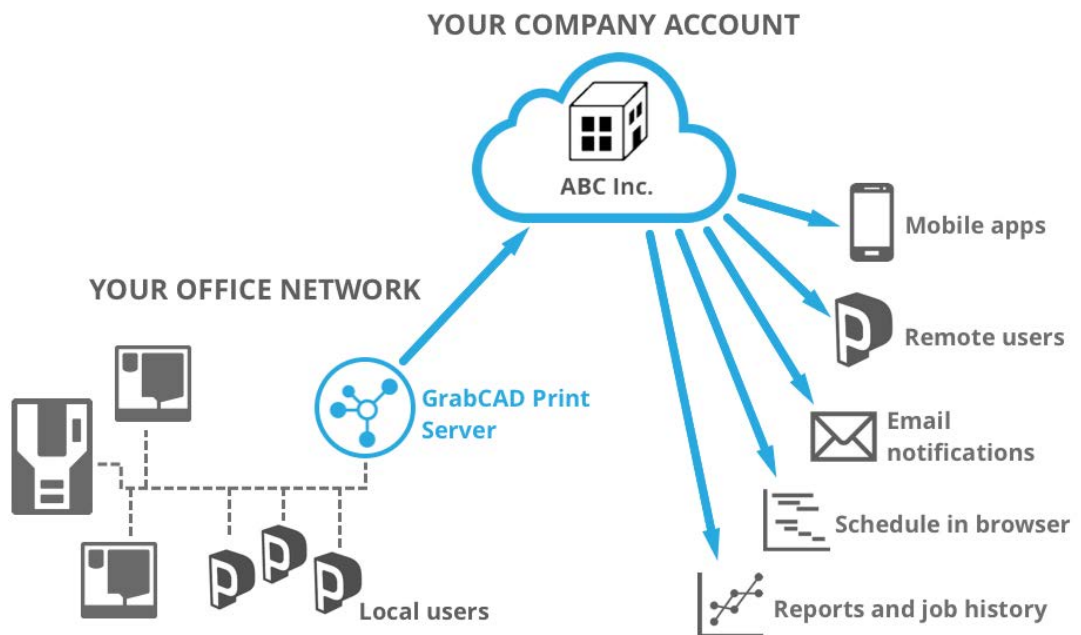
GrabCAD Print Server

GrabCAD Print Server runs as a Windows service on a customer-controlled Windows computer. It runs on the local area network (LAN) and connects to the GrabCAD web service running on the cloud. The GrabCAD Print Server expands the features of GrabCAD Print to:

- Run GrabCAD Print from a computer on or outside the network.
- Program jobs and send them to printers on the network.
- Monitor printer schedules and status from GrabCAD Print, from a preferred browser on grabcad.com, or from GrabCAD Print Mobile on IOS and Android devices.
- Review printer job history from GrabCAD Print or grabcad.com.
- Review material and printer usage analytics on grabcad.com.

Access to GrabCAD Print Server enabled features requires a GrabCAD user account and membership in the company account referenced by the GrabCAD Print Server. A company account links to all of the features of the GrabCAD Print Server as shown in the image below.

Figure 82: GrabCAD Print Server



Setting up GrabCAD Print Server

GrabCAD Print Server requires: a Windows computer that is always connected to a local area network. The Windows computer must be:

- Windows 11 or newer
- Windows Server 2016 or newer
- 64-bit architecture only (32-bit is not supported)

As stated earlier, administrator rights are required to install GrabCAD Print Server on a computer. Once GrabCAD Print Server is installed, sign in and select the company account for printers on the LAN. GrabCAD Print Server automatically detects printers on the network. A printer can also be added by entering its IP Address. GrabCAD Print Server will run in the background as long as the computer is running, and will restart automatically when its host computer is restarted.

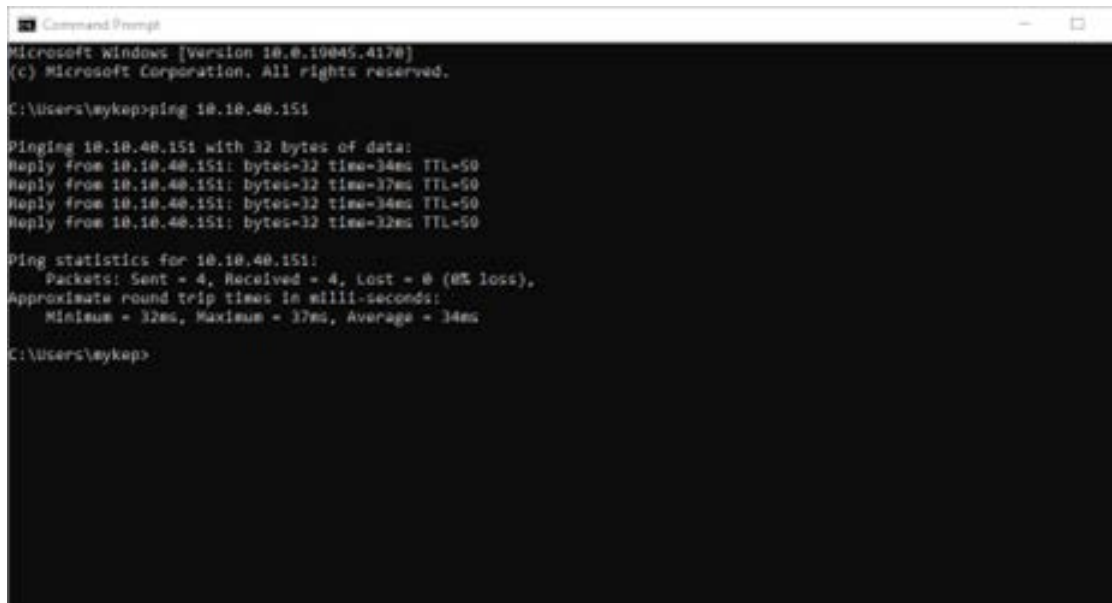
For additional information about GrabCAD Print and GrabCAD Print Server system requirements, click [here](#).

Connecting to the F3300 printer in GrabCAD Print

To use an F3300 with GrabCAD Print either offline or online:

1. Confirm the computer is on the same network as the F3300.
2. Write down the IP address of the F3300.

Figure 83: Confirm printer is on the same network



```
Command Prompt
Microsoft Windows [Version 10.0.19045.4170]
(c) Microsoft Corporation. All rights reserved.

C:\Users\laykep>ping 10.10.40.151

Pinging 10.10.40.151 with 32 bytes of data:
Reply from 10.10.40.151: bytes=32 time=34ms TTL=50
Reply from 10.10.40.151: bytes=32 time=37ms TTL=50
Reply from 10.10.40.151: bytes=32 time=36ms TTL=50
Reply from 10.10.40.151: bytes=32 time=32ms TTL=50

Ping statistics for 10.10.40.151:
    Packets: Sent = 4, Received = 4, Lost = 0 (0% loss),
    Approximate round trip times in milliseconds:
        Minimum = 32ms, Maximum = 37ms, Average = 34ms

C:\Users\laykep>
```

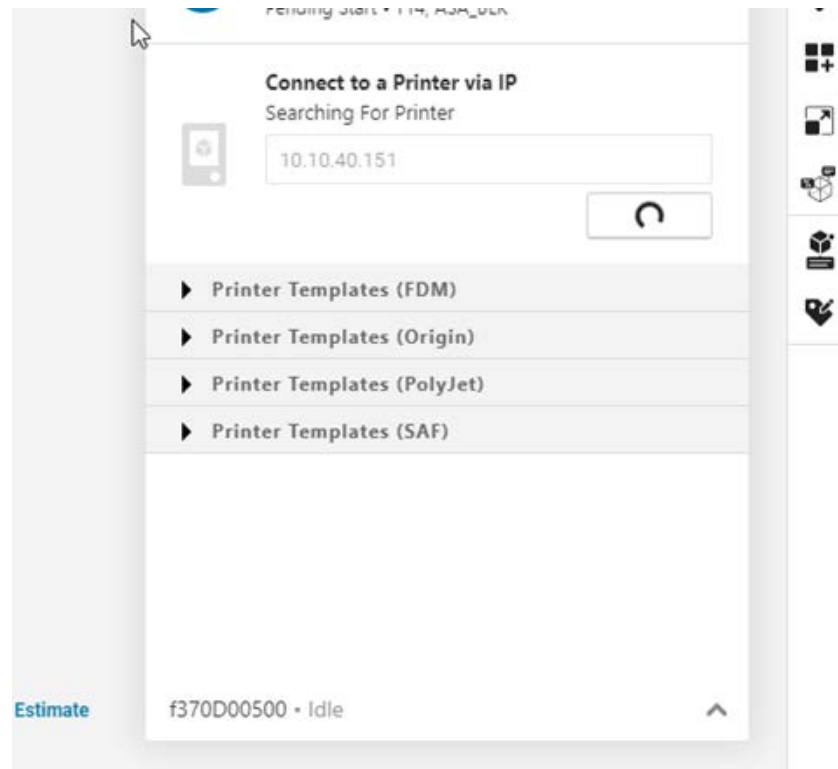
3. Launch GrabCAD Print using the Applications menu or clicking the desktop icon.

If this is the first time that GrabCAD Print is being used on this computer:

- Sign in with your username and password and choose your company account.
- or
- Continue working in offline mode.

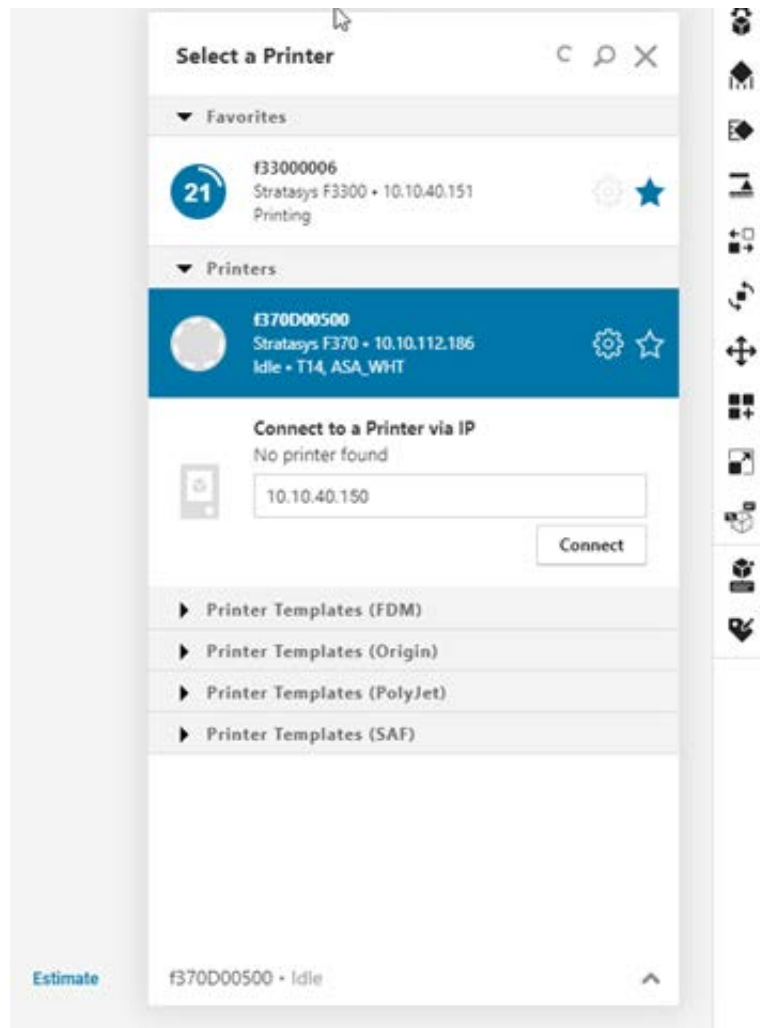
4. Open the **Printer Panel** in GrabCAD Print. Enter the IP address of the F3300 in the **Connect to a Printer via IP** text box. Click **Connect**.

Figure 84: Searching for a printer to add by IP address



5. GrabCAD Print searches for the printer, adds it to the printer list if it is found, or informs you if it is not found.

Figure 85: Printer found



To use an F3300 with GrabCAD Print and GrabCAD Print Server:

1. Launch GrabCAD Print and sign in.

Figure 86: Signing in

2. Choose the company account that includes the F3300 printer.

Figure 87: Choosing the company account

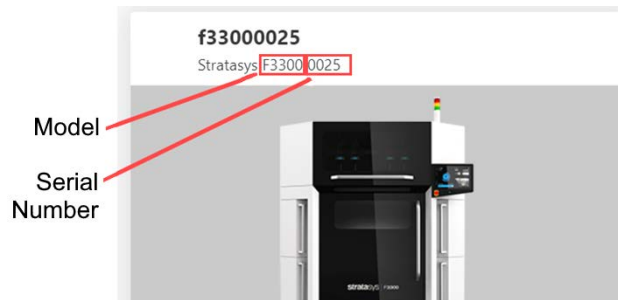
3. Open the **Printer** panel and scroll to the F3300 printer. Alternatively, use the **Search** field at the top of the **Printer** panel to locate the F3300. An F3300 may be searched by its name, model, IP address, printer state, materials, and nozzles currently loaded on the printer.
4. Select the F3300. Its current setup, including items such as materials and tools, is copied to GrabCAD Print for use while programming.

Viewing Printer Details

Using Print View

Open the **Printer** panel, find the desired F3300 printer, and click the gear icon to open its **Detail** panel. The model and serial number are displayed at the top of the F3300 printer panel.

Figure 88: Print view ID



Using Schedule View

Scroll through the list of printers to find the desired F3300. Click the row header. The **Printer Details** panel displays. The model and serial number are shown at the top of the panel.

GrabCAD grabcad.com

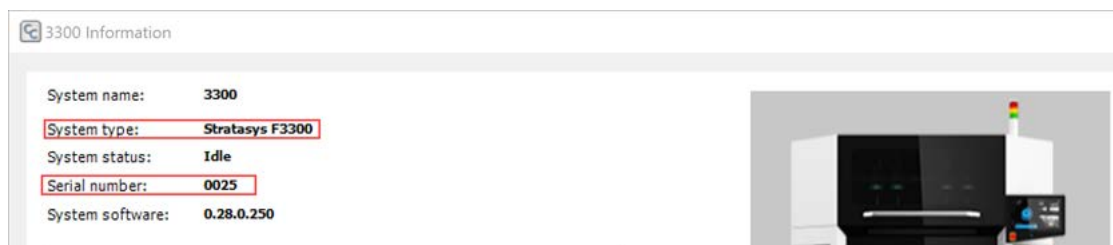
To view printer information online, GrabCAD Print Server must be installed and include the IP addresses for the printers in your company:

1. Navigate to login.grabcad.com.
2. Sign in.
3. Select an app (**Control**, **Analyze** or **Shop**) if you have more than one.
4. Select **Schedule** from the left-hand navigation bar.
5. When the schedule view window displays, select the row headers of your F3300 printer to view its printer information.

Control Center

Select the **Services** tab. Select the desired F3300 printer from the **Name** drop-down list. Click **System Info**. The System Type and Serial Number fields are displayed near the top of the Information dialog box.

Figure 89: Control Center ID



Creating Print Jobs Using GrabCAD Print

The steps required to create a print job are shown below.

Set Up a Tray

To set up a tray, keep the default settings, copy the settings from a selected F3300 printer, or choose settings for material, color, and slice height.

Figure 90: Change Materials and Slice Heights

Change Materials and Slice Heights

Add or change materials. Material, color and slice height may be changed.
4 materials added.

Material (Primary)	Color	Slice height
F3000 ASA	Black	<input checked="" type="radio"/> 0.2500 mm N500 <input type="radio"/> 0.5000 mm N750
F3000 SR35 Support	White	<input checked="" type="radio"/> 0.2500 mm N410 <input type="radio"/> 0.5000 mm N750
☆ Material	Ivory	<input checked="" type="radio"/> 0.2500 mm N500 <input type="radio"/> 0.5000 mm N750
☆ Material	Red	<input checked="" type="radio"/> 0.2500 mm N500 <input type="radio"/> 0.5000 mm N750

Read Materials from Printer Cancel Change



The first material in the list is the primary material. The primary material is the default material for models added to the tray.

Click ☆ to make a material primary and 🗑️ to delete it.

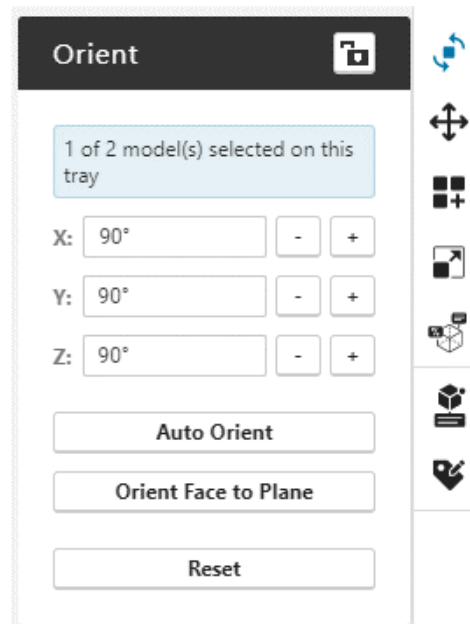
Add Models for Printing

GrabCAD Print supports parts and assemblies from common CAD applications such as Solidworks, Creo, NX, Inventor, and CATIA, among others. It supports data exchange formats like STEP and IGES as well as faceted formats like STL, 3MF, and WRL among others.

Orient Models

Keep the default orientation or change it to one better suited for the current print job.

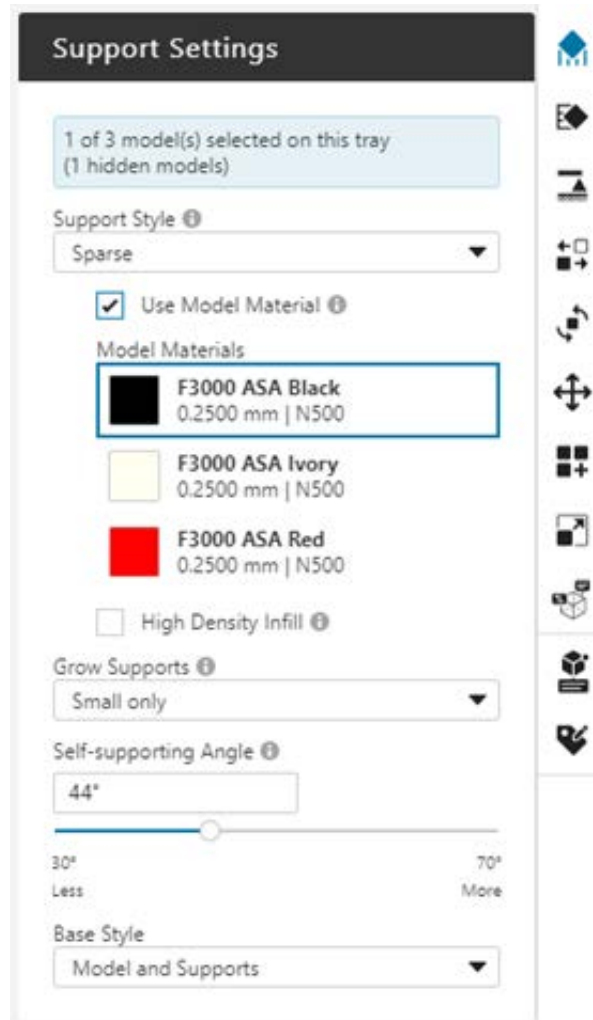
Figure 91: Orient panel



Change Support Settings

Supports are generated automatically. Review and accept the defaults based on the material and the slice height or change it to something that works better for the current print job.

Figure 92: Support settings



Modify Print Settings

GrabCAD Print allows for varying settings for models on a tray, for bodies in a model, and for faces and features in a body. Assign settings as required for the best print job results.

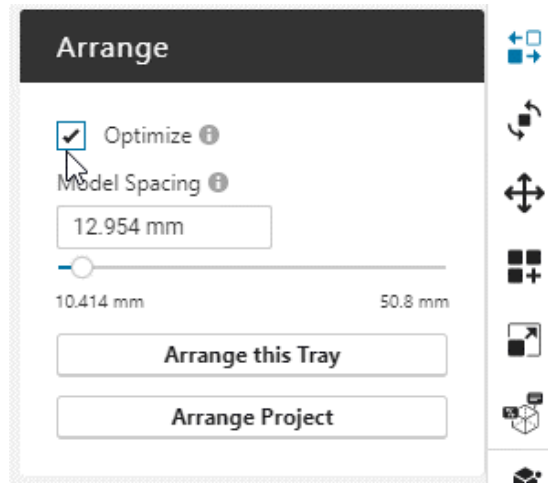
Figure 93: Model settings



Placing Parts on a Tray

Use the arrange tool to place the print job parts. Click the **Arrange this Tray** box or click the **Optimize** button and calculate the toolpaths.

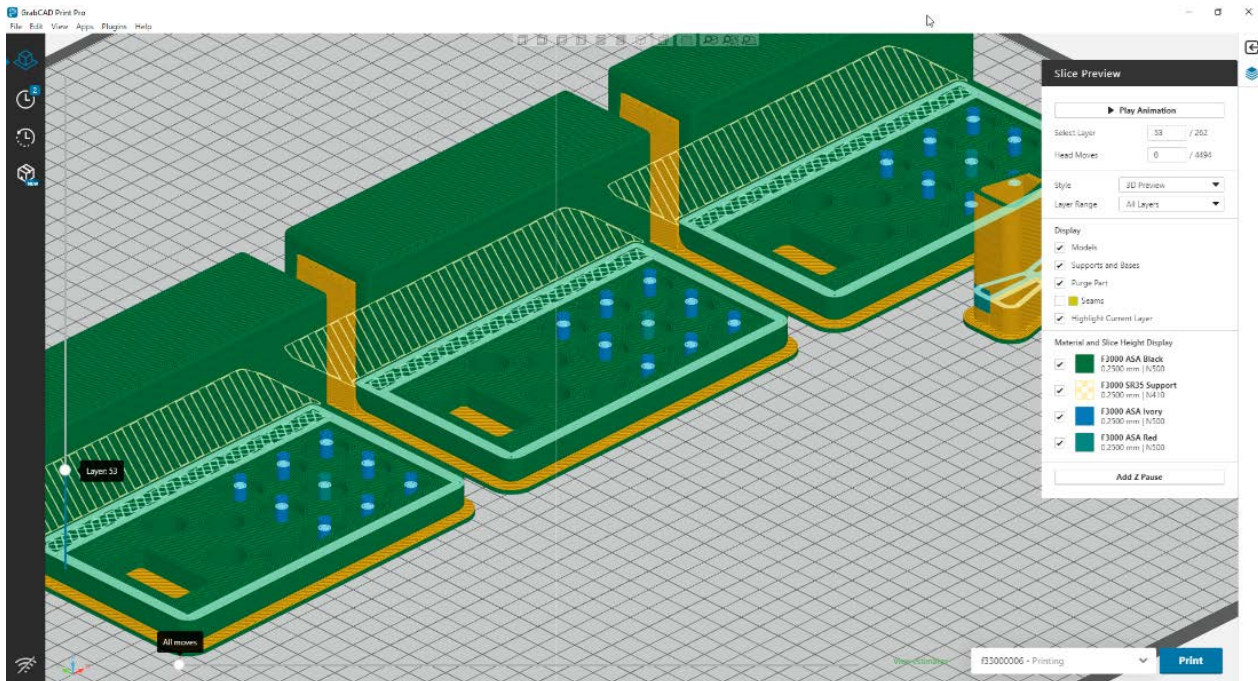
Figure 94: Arrange panel



Check the Toolpaths

Use **Slice Preview** to confirm the selected materials and slice heights and that the toolpaths represent the process plan.

Figure 95: Slice Preview



Using the Insight as a Companion Application

Insight is the toolpath engine for GrabCAD Print, and is available from the Apps menu. Open Insight, import an STL, program the part, send it back to GrabCAD Print for placing with other CMBs, and then send it to the printer.

Data Sharing with Stratasys Using GrabCAD

GrabCAD Print and GrabCAD Print Server provide many options for users and administrators to control data sharing:

GrabCAD Print Offline

When working offline GrabCAD Print shares no data. To work offline, see “/offlineMode” (page 86) or launch GrabCAD Print and select **File | Preferences**. Next select the **Privacy** tab and check **Use GrabCAD Print in Offline Mode**.

GrabCAD Print Online with Privacy Controls

When using GrabCAD Print enabled by GrabCAD Print Server, a user can opt out of data sharing. To opt out of data sharing, select **File | Preferences**. Next, select the **Privacy** tab and uncheck data sharing options for the following:

- **Automatically send anonymous usage statistics to Stratasys**
- **Automatically send personal statistics to Stratasys**
- **Automatically share tray images with your company account**

Users may also opt out of data collection during GrabCAD Print installation. Electing to work offline or change data sharing options requires administrative privileges.

GrabCAD Print Server

To opt out of anonymous data collection during or after installing GrabCAD Print Server, select **Help** and uncheck **Automatically send anonymous statistics**.

GrabCAD and GDPR

GrabCAD complies with the European Union’s General Data Privacy Regulation (GDPR). For any questions, please contact support@grabcad.com.

Insight Software

(Insight and related software are an alternative to GrabCAD Print and GrabCAD Print Server)



For detailed information and instructions on using Insight, see the associated Help file within the Insight application (available by selecting the Help option within the Insight toolbar).

Insight software is installed on your workstation PC as part of the initial installation and setup process (performed by your authorized service representative). Insight is the software used to process job files and then transfer them to the printer to be built. The F3300 builds parts by processing the original STL job file into a Stratasys CMB file that is downloaded to the printer. To build a job, you must send the job file to the F3300 using the Insight application.



FDM Control Center is an application that connects with Insight software to send jobs to the printer to be built. For detailed information about using FDM Control Center, use the associated Help file within the application.

Jobs are sent to the printer in CMB format and are placed into the Job Queue (stored on the printer's SD memory card). The header of the CMB file contains the processed job's basic information (material type, approximate material amounts required for the build, tip size, etc.). This information is used to verify job compatibility with the printer's materials/tips configuration.

To start Insight, navigate to **All Programs > Insight (installed version) > Insight (installed version)** from your workstation's Start Menu or double-click on the Insight desktop shortcut (if available).

Insight STL file processing consists of:

1. Configuring the modeler (printer).
2. Orienting the STL model.
3. Slicing the STL model.
4. Creating support curves (defining where temporary supports will be built).
5. Creating toolpath fill for model and support curves.
6. Saving a toolpath file (CMB file).
7. Downloading the toolpath file to the modeler (printer), via FDM Control Center, to be built.

FDM Control Center Software

FDM Control Center is an application that connects with Insight software to send jobs to the printer to be built. Control Center is designed to be used with your network-based Stratasys printer. Insight performs the model processing to prepare a CMB file and Control Center connects to the printer to build the job and monitor the printer's status.



For detailed information about using FDM Control Center, see the associated Help file within the application (available by selecting the Help option within the Control Center toolbar).

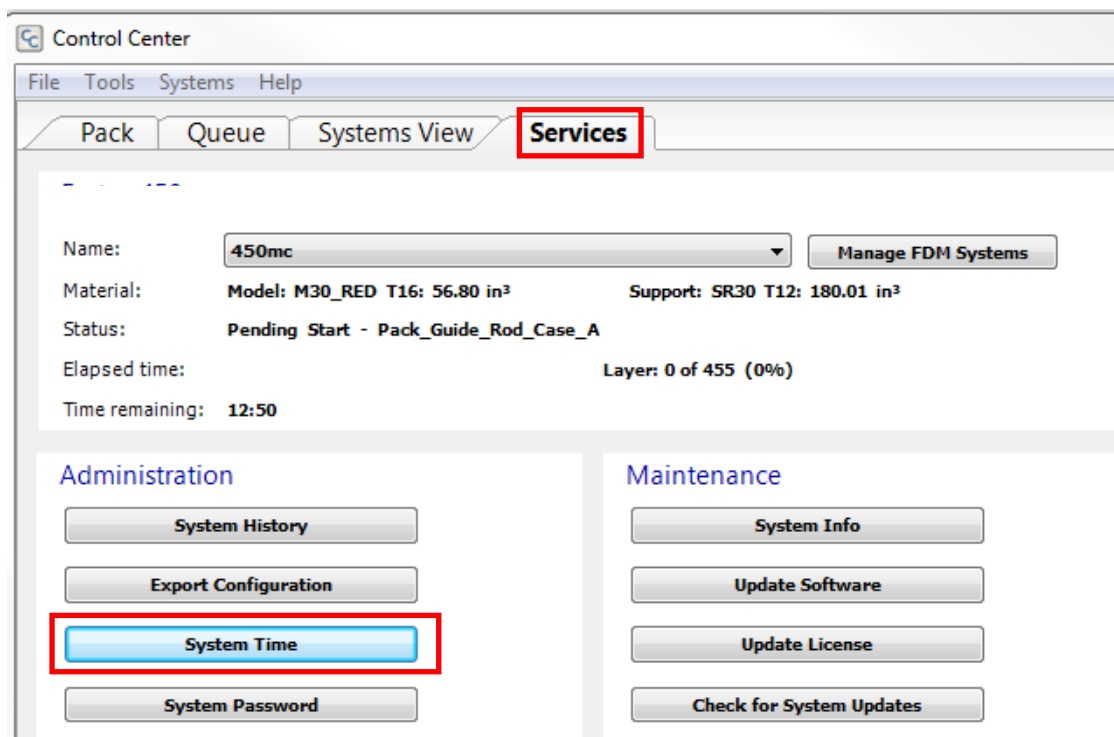
Control Center software is packaged together with Insight software, and is installed on your workstation PC as part of the initial installation and setup process (performed by your authorized service representative). During the software installation process, your printer's network information should have been configured within Control Center allowing you to send CMB files to the printer. If you find that you are unable to select your printer from the drop-down menu within Control Center, you will need to add your modeler (printer) to your list of available FDM systems.

Setting the Printer's Date and Time (FDM Control Center)

In order to ensure accurate build times, the printer's clock must be set. This can be done within the FDM Control Center application which was installed on your workstation PC as part of the installation process (see ["FDM Control Center Software" \(page 101\)](#)). Perform the following steps to set the printer's date and time:

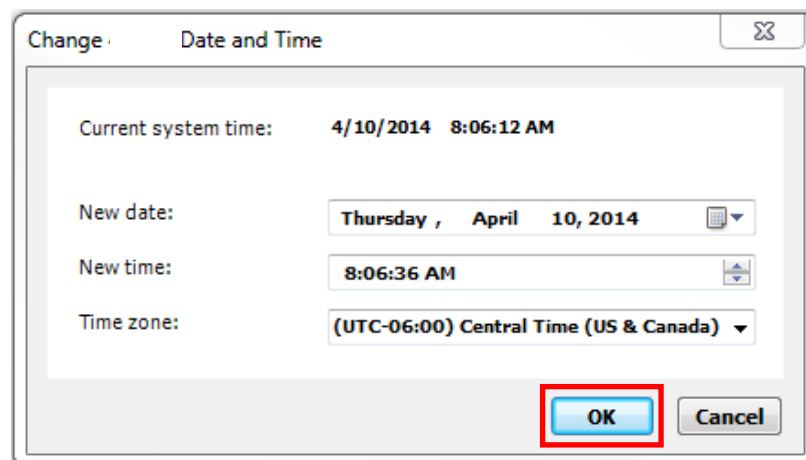
1. Open FDM Control Center by navigating to **All Programs > Insight (installed version) > Control Center (installed version)** or double-clicking the Control Center shortcut (if available).
2. Select the *Services* tab, and ensure that your printer is selected from the *Name:* drop-down menu. If your printer is not available from the drop-down menu, you will need to add the printer within Control Center.
3. Click **System Time**.

Figure 96: System Time Button Location



4. The *Change Date and Time* dialog will be displayed. The date and time settings within this dialog are automatically configured based on the workstation PC's date and time settings.
5. Adjust the date and/or time setting if needed, then click **OK** to close the dialog.

Figure 97: Change Date and Time Dialog



Setting the Printer's Date and Time (GrabCAD Print)

For an idle printer:

1. Open GrabCAD Print.
2. Expand the printer panel and find your Stratasys F3300 printer.
3. Select the Gear icon, then select **Settings**.
4. Select **Edit**.
5. Change the date, time, and time zone.
6. Click **Save** to apply the changes.

Figure 98: Setting Time in GrabCAD Print

← **f3300TA0001** ×
Stratasys F3300 TA0001

Settings

11/11/2025 02:16 PM
(UTC-05:00) Eastern Time (US & Canada)

Cancel Save

Current Firmware Version: 3.6.0.688
Firmware update is available 3.7
To update the firmware, go to the printer and turn on update mode while idle.

Costing Rates Edit

Alias: ⓘ No alias specified Edit Clear

Printer Name: f3300TA0081 Edit

[Export printer configuration](#)

Stratasys F3300 • Template

Updating the Controller Software Version

Update the controller software if necessary. See [“Calibration and Adjustments”](#) (page 196).

Adjusting the Tip Wipe Height

If necessary, adjust the tip wipe height. See [“Tip Wipe Height Adjustment”](#) (page 184).

Stratasys Online Resources

Stratasys encourages you to learn more about additive technologies and your Stratasys printer. A wealth of information is available on our online platforms.

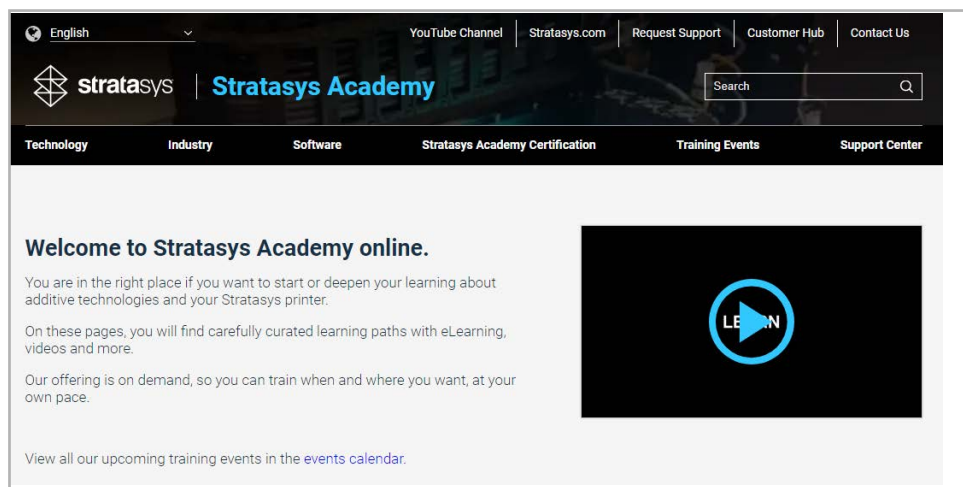
Subscribe to our customer newsletter for quarterly updates on Stratasys knowledge and training. You can learn about the release of new documentation and learning resources.

Stratasys Academy

[Stratasys Academy](#) is your online learning platform where you can quickly learn and acquire skills on additive technologies and your Stratasys printer.

To guide you in your learning, our online academy provides a variety of resources such as an extensive library of videos and eLearning modules. We periodically update the site with new content. Start your learning journey today.

Figure 99: Stratasys Academy



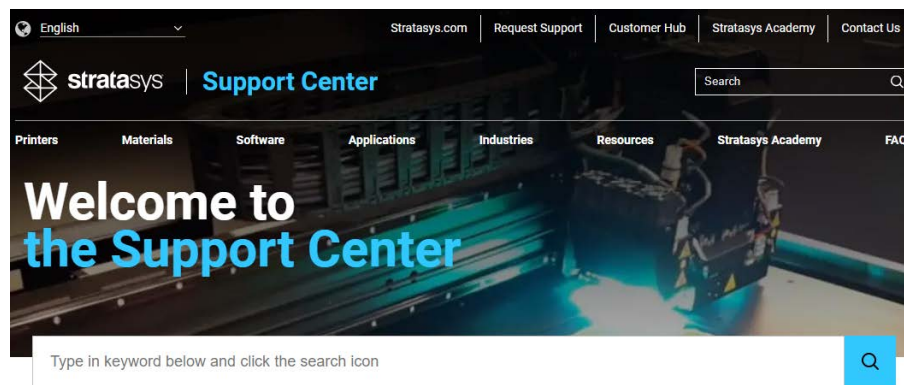
Stratasys Support Center

The [Support Center](#) is a knowledge base that includes information about design, applications, printing material, and links to many other resources such as [GrabCAD Help Center](#).

In addition, you can check the latest revision of the user guide for your Stratasys 3D printer and download documents in different languages.

The Support Center is available in multiple languages. You can change the display language using the language drop-down menu in the top-left corner of the homepage.

Figure 100: Support Center

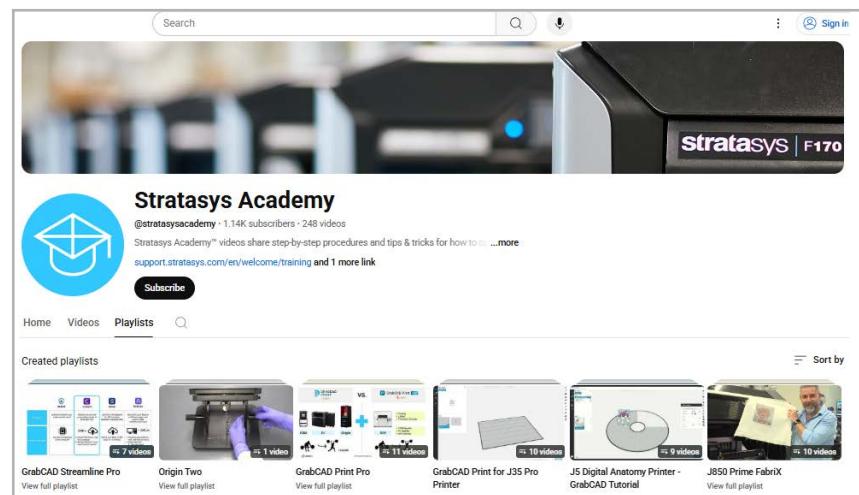


Stratasys Academy YouTube Channel

The [Stratasys Academy YouTube Channel](#) features instructional videos about how to operate and maintain Stratasys printers. The channel includes dedicated playlists for different printers and special topics like post-processing.

Make sure to check out this new Stratasys Academy Channel and remember to subscribe!

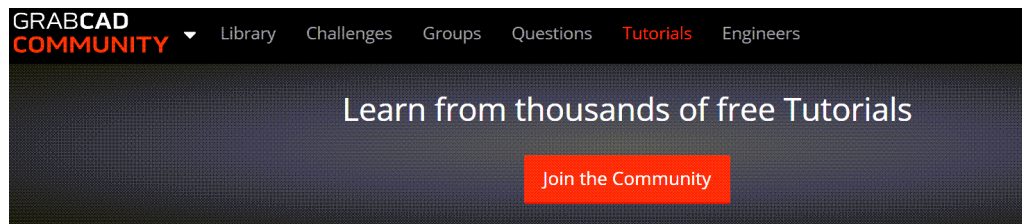
Figure 101: Stratasys Academy YouTube Channel



GrabCAD Community

The [Tutorials section of the GrabCAD Community](#) portal is a valuable resource for Stratasys-sponsored and user-generated 3D printing tips. You can also ask 3D-related questions on the portal and download free CAD files.

Figure 102: GrabCAD Community



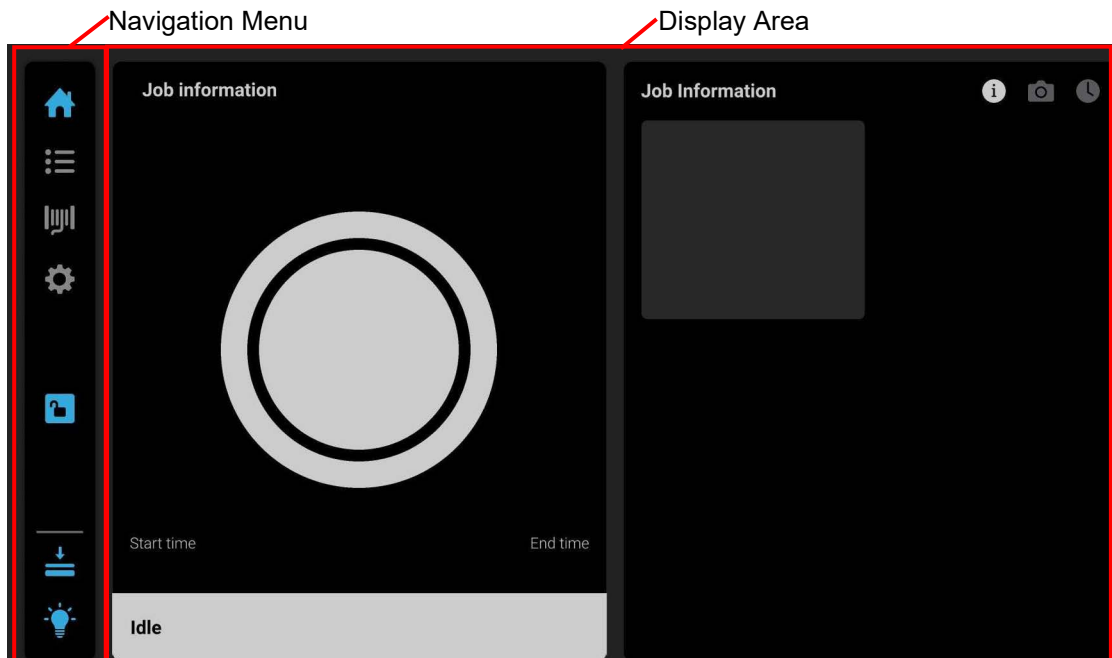
5 User Interface

This chapter provides an overview of the F3300 printer User Interface (UI). Specific printer operation information and procedures can be found in [Chapter 6, Operating the Printer \(page 146\)](#). You must power ON the printer prior to using the touchscreen (see “Powering On the Printer” (page 146) for instructions).

Overview

The User Interface is composed of a touchscreen located on the front right face of the printer (see [Figure 2 \(page 6\)](#)). Each page of the UI is composed of two main areas of functionality; these items are highlighted in [Figure 103](#).

Figure 103: User Interface Overview



The touchscreen is easy to use and allows you to:

- Access material load and unload.
- Monitor printer status.
- Monitor material drive and hot end statuses (types loaded/installed, material volumes, drive and hot end odometers, etc.) and change materials and/or hot ends when necessary.
- Monitor build progress (name of job being built, materials usage information, estimated completion time, etc.).
- Access network configuration information and change printer defaults.
- Access the Job Queue and Sample Queue (internal storage).

Navigation Menu

The Navigation Menu provides one-touch access to the Home/Build, Queue, Consumables, and Settings menus of the printer (see [Figure 103](#) for details). The User Interface is broken up into several pages of related functionality. Selecting a button from the Navigation Menu will open the button's corresponding page, allowing you to perform tasks within that page. If a page contains sub-pages, additional buttons corresponding to these items will be displayed within the page's Display Area.

The buttons in the Navigation Menu are mutually exclusive, meaning only one button may be selected at a time. In some cases, a notification badge will be displayed within the button indicating a warning related to the functionality of the corresponding page. Buttons can appear as follows:

After selecting a button from the Navigation Menu, the selected button will change color from gray to blue indicating which menu active. This makes it easy to determine which UI page is being viewed.

Figure 104: User Interface Overview



Display Area

The Display Area contains the body portion of each page of the User Interface; this is where you can select from available functions and view current status. After selecting a button from the Navigation Menu, the Display Area will refresh and the main page corresponding to the selected button will be displayed. The information and buttons/icons shown within the Display Area will vary depending on which main page of the UI was selected.

Working with the Home Page

The Home page is composed of multiple areas of functionality that are necessary for building parts on the printer; these items are highlighted in [Figure 105](#). Within the Build page you can start, pause, and abort a job, view a build time estimate for the selected job, see status and estimated action points for a job in progress, and view a visual representation of the completed part. Please note that you must load a job file to the printer and select the file to be built before the job's details will be displayed within the Build page.

The Home page also contains the Notifications Display. Depending on the state of the printer a variety of notifications/warnings will be displayed within this area of the page. Touching the text on the screen will open a dialog indicating the reason(s) for the notification, and in some cases, steps to correct the notification (see [Figure 106](#)). Once all notifications have been corrected, press the **Close** button within the dialog to exit the dialog.

To access the Home page, press the **Build** button within the Navigation Menu. When there is not a build job in the queue, a screen similar to the one in [Figure 105](#) will be displayed. If there is a build job in the queue, a screen similar to the one in [Figure 106](#) will be displayed.

Figure 105: Home Page - No job in queue

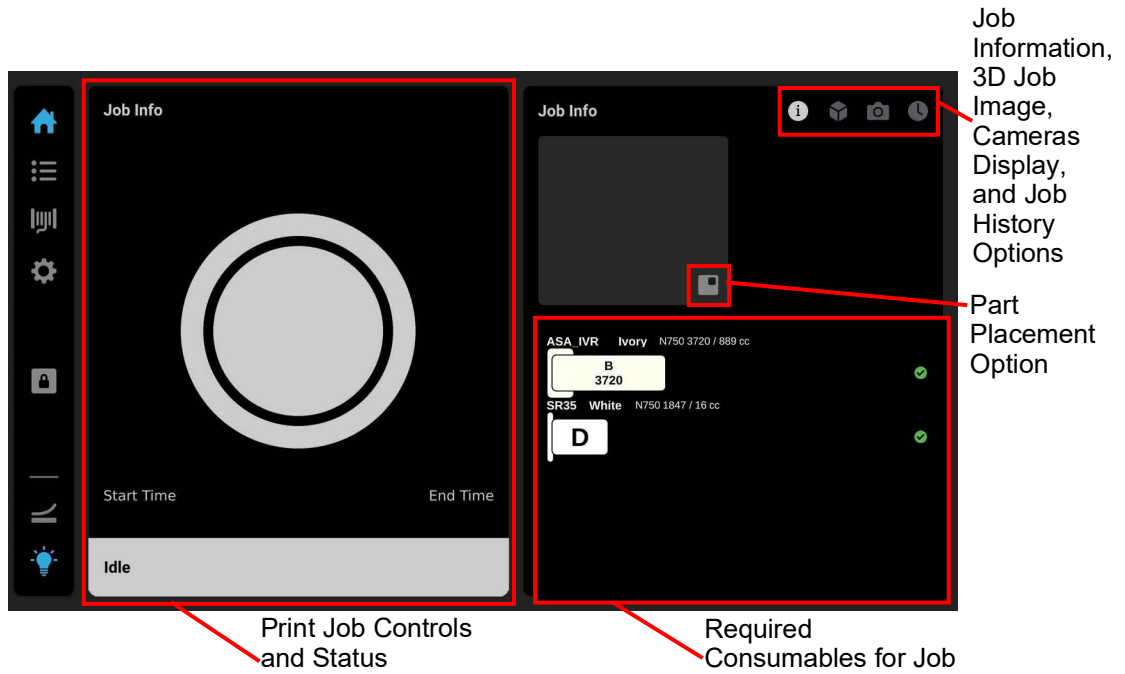
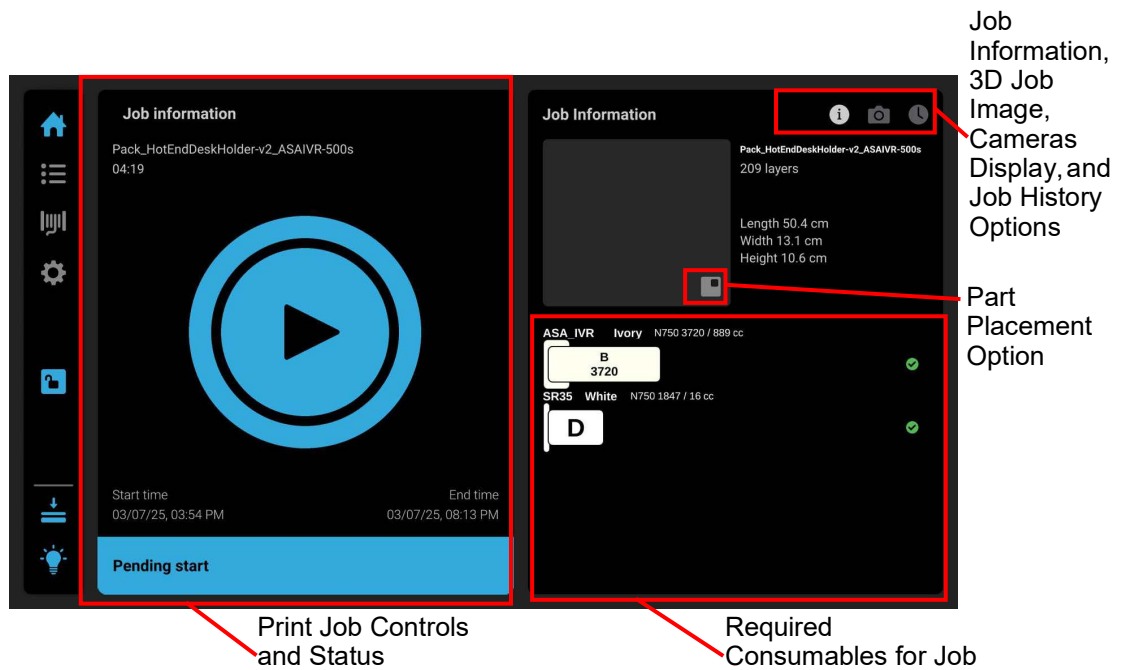


Figure 106: Home Page - Job in queue



If **Could Not Start Build** message is displayed in the print job status (see [Figure 107](#)), pressing the **Start** button will display a window detailing the conditions that must be addressed before printing will begin (see [Figure 108](#)).

Figure 107: Could Not Start Build

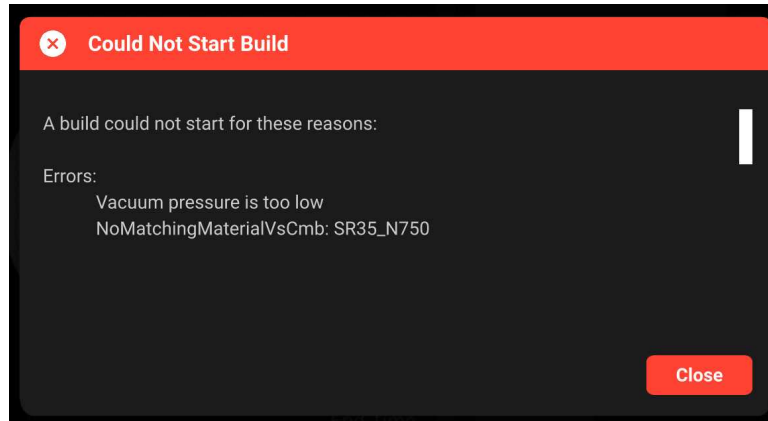
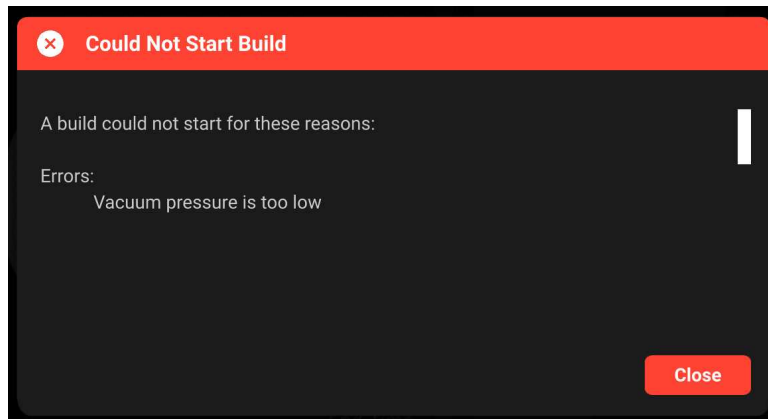


Figure 108: Could Not Start Build - Start pressed



Loading a File



A job file must be loaded onto the printer and selected for building before the job's details will be displayed within the **Build** page.

The Print Job Information Panel is empty upon initial startup and the **Build Status Display** reflects its idle state.

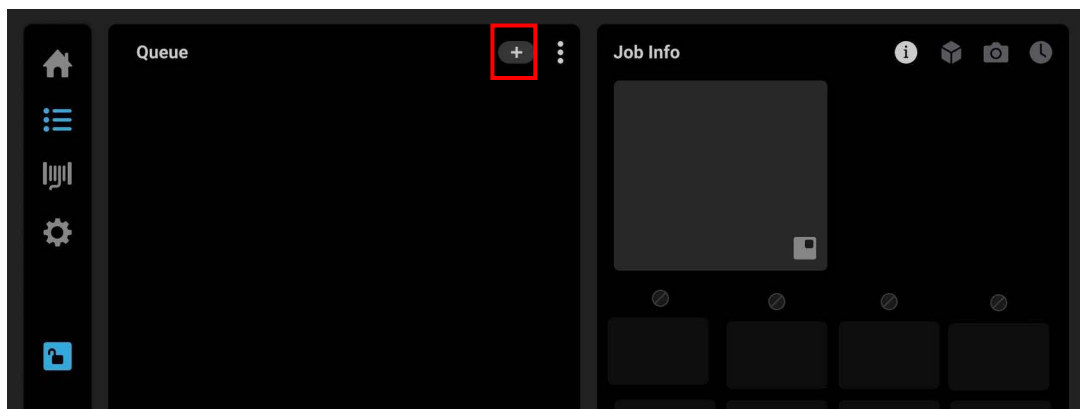
A job must be selected for building before the job's details will be displayed within the **Build** page. In order to build a job, you must first load the job's corresponding job file to the printer. Job files can be loaded via network transfer (Ethernet) using the GrabCAD Print application or Insight Control Center application on your workstation PC or by plugging a USB flash drive into one of the printer's USB ports and navigating to the job file via the **Queue** page (see ["Adding a Job to the Job Queue"](#) (page 124) for details). The job file you wish to build must be the first item listed in the **Job Queue**. Job files can be sorted as needed within the **Queue** page allowing you to select the job you'd like to build (see ["Editing the Job Queue"](#) (page 126) for details).

- If you send a single job file to the printer via network transfer using GrabCAD Print, the job's details will automatically be displayed within the **Build Status Display** once the job file is received by the printer, as this job will be the only item in the Job Queue. The **Load File** button will be hidden from view once the job file is received by the printer via network transfer.
- If you send two or more job files to the printer via network transfer using GrabCAD Print, the job details of the first file sent will automatically be displayed within the **Build Status Display** once the job file is received by the printer, as jobs are built in the order they're sent to the printer. The **Load File** button will be hidden from view once the first job file is received by the printer via network transfer.

To load a file using the USB port:

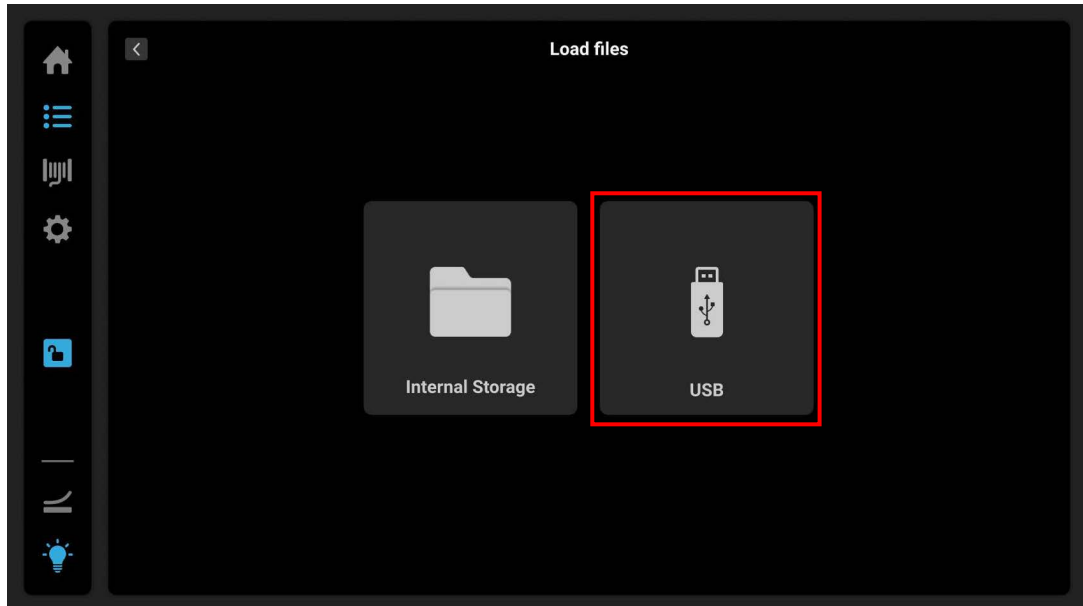
7. Plug a USB flash drive into the USB port on the front of the printer.
8. Press the **Queue** menu button. The queue menu display.
9. Press the + button.

Figure 109: Queue menu



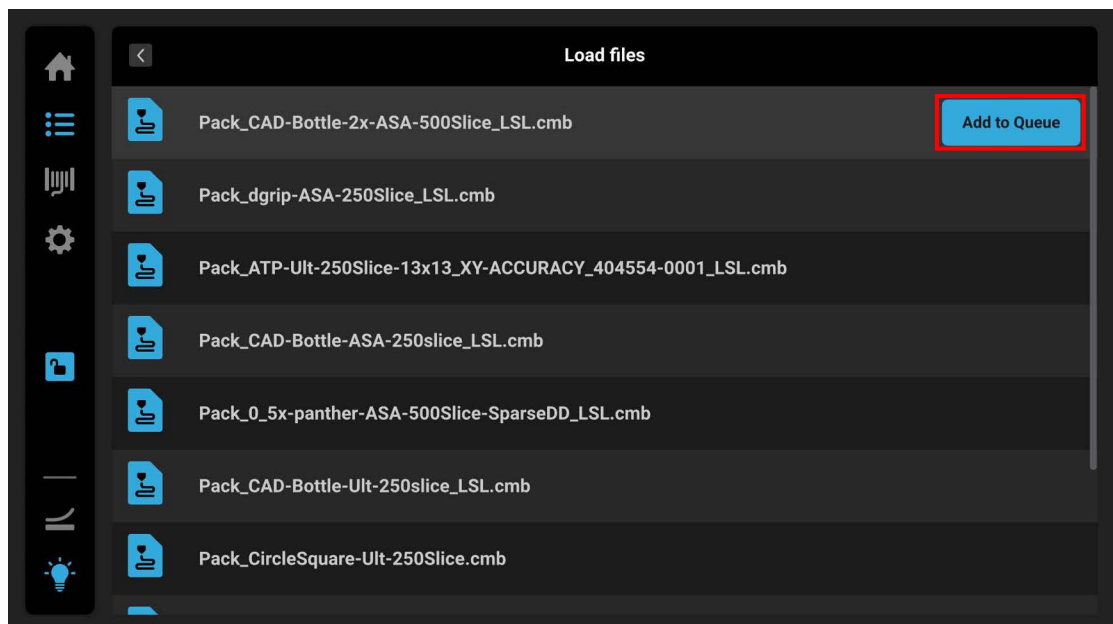
- The USB and Internal Storage options display.

Figure 110: Load File Page - USB Option



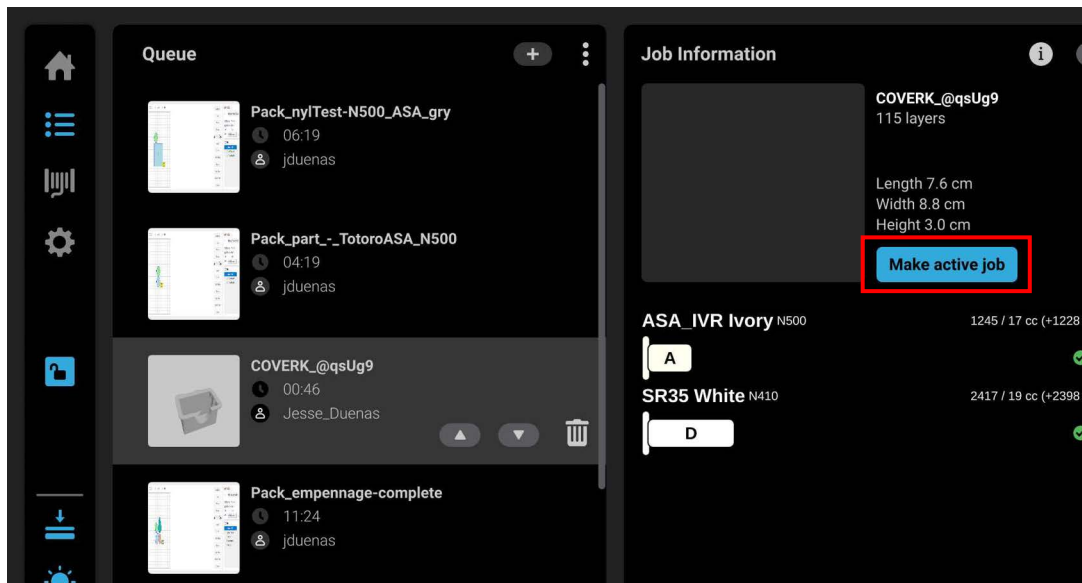
- The **Load File** page will display the contents of the USB flash drive. Locate the desired job and select it by touching its row on the screen.
- Within the Job Details page press the **Add to Queue** button; this will load the job into the Job Queue.

Figure 111: Add File to Queue



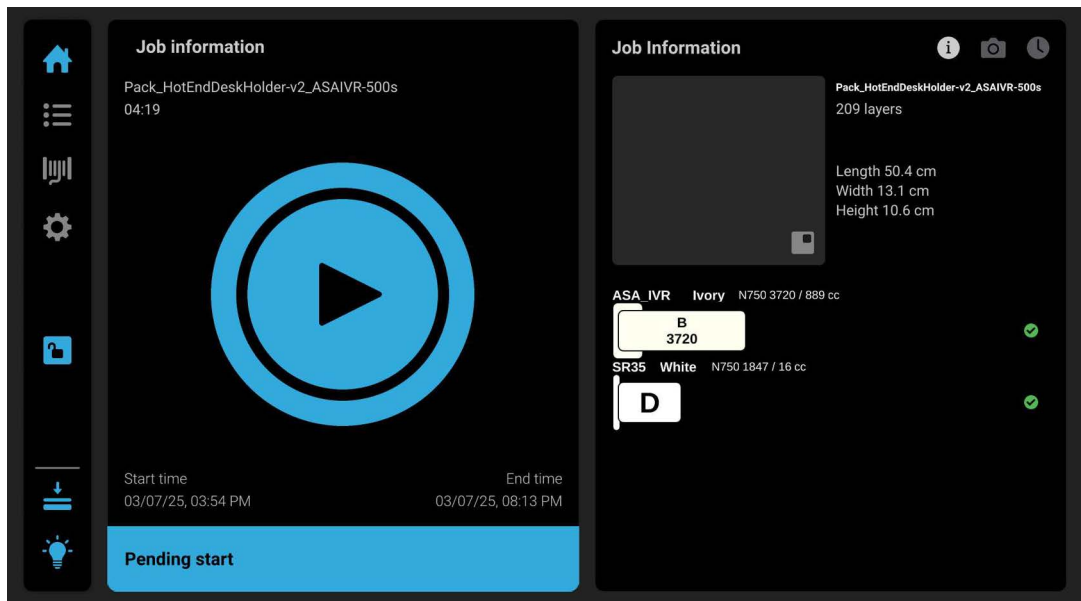
- After pressing the **Add to Queue** button you will be returned to the **Queue** menu. If the job selected and added to the queue is the only job in the queue, it will become the active job. If there are other jobs in the queue, select **Make Active Job** to promote it to the top of the list.

Figure 112: Promote a build job



- Press the **Home** button and then press the **Print** button to begin the build job.
- Pressing the **Print** button within the **Build** page will initiate the build. Build progress will be displayed within the Build Status Display, see [“Build Status Display” \(page 115\)](#) for details.

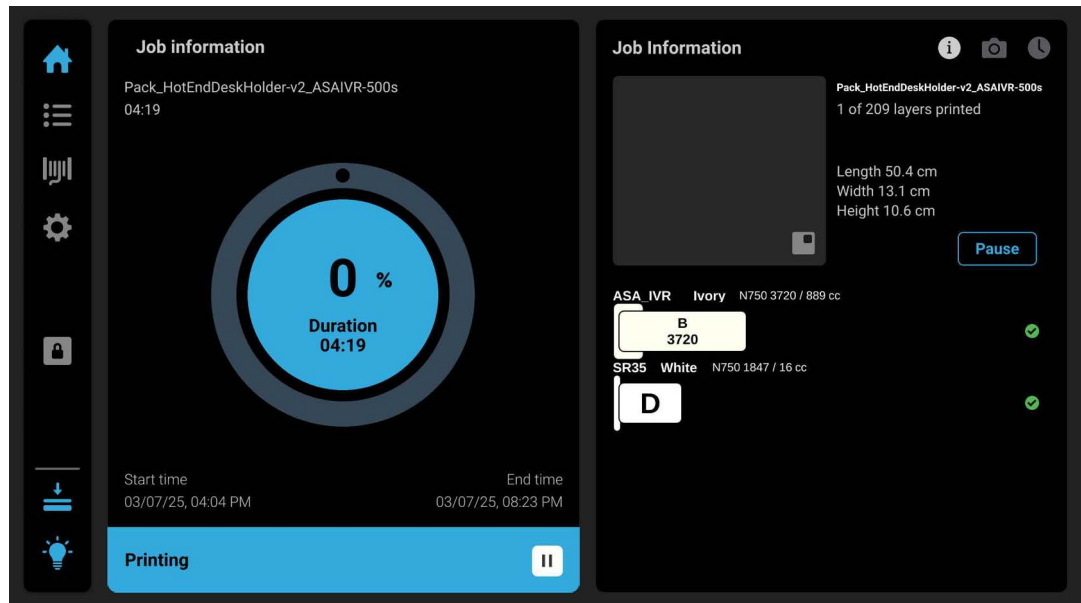
Figure 113: Home Page with Job Information



Viewing Print Job Information

Information pertaining to a selected job is displayed within the **Home** page.

Figure 114: Print Job Information



These two sections display a variety of information pertaining to the selected job, including:

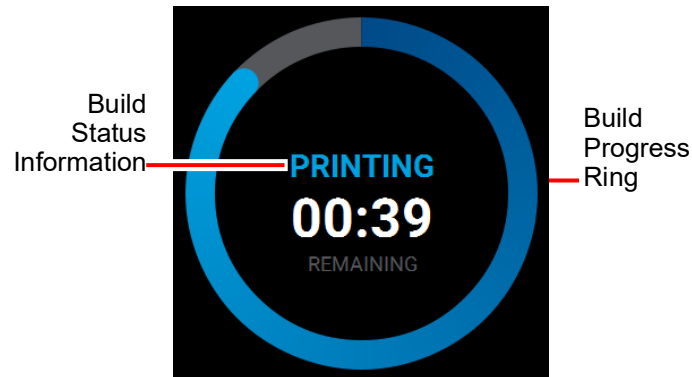
- Name of the job.
- Estimated build time for the job.
- Percent completed when building
- Part Dimensions
- Hot End Associated with the job
- Model and support materials and quantities required for job.
- Model and support materials associated with the job.

Touching any of the top right buttons will display additional information and details pertaining to the job. (see [“Viewing Job Details” \(page 127\)](#)).

Build Status Display

The Build Status Display section of the Home page is composed of a two-part graphic. The left portion provides information on a selected and/or building job while the outer progress ring corresponds with the build information displayed; the information displayed will vary depending on the state of the printer.

Figure 115: Build Status Display Overview



Idle

When the printer is idle, "IDLE" will be displayed within the center of the Build Status Display. This indicates that the printer is in a state where it is ready to start a build. No progress is indicated within the outer build progress ring and the time remaining is displayed as zero.

Figure 116: Build Status Display - Idle



Building



A job file must be loaded onto the printer and selected for building before build information will be displayed within the Build Status Display. See [“Loading a File” \(page 111\)](#) for details.

After pressing the **Play** button to start a build, "HEATING" is briefly displayed within the Build Status Display, and center circle will turn orange. The Build Status Display area next changes to Calibrating. The printer will pick up the required model tool and calibrate it using a built in inductance sensor. Once the model calibration is completed, the tool returned to the rack and a support tool is picked up and calibrated.

On the first calibration after powering on the printer, the model tool is used to level the platen. A new build sheet must be used after power on because the printer will touch on the four corners and center of the platen.

Subsequent builds after the first calibration will only touch on the center of the bounding area for the then current build job. Only that area needs to be clean.

After Calibration, the status changes to Heating and then to Printing.

Once printing, the circle displays the amount of time completed in both percent and time. The right side of the Home page displays the layer built out of the total number of layers for the job.

Figure 117: Build Status Display - Building



Extruder Drive Light Display States

The extruder drive assembly displays different colors depending on tool status. While calibrating and building these colors change to indicate heating and building or idle.

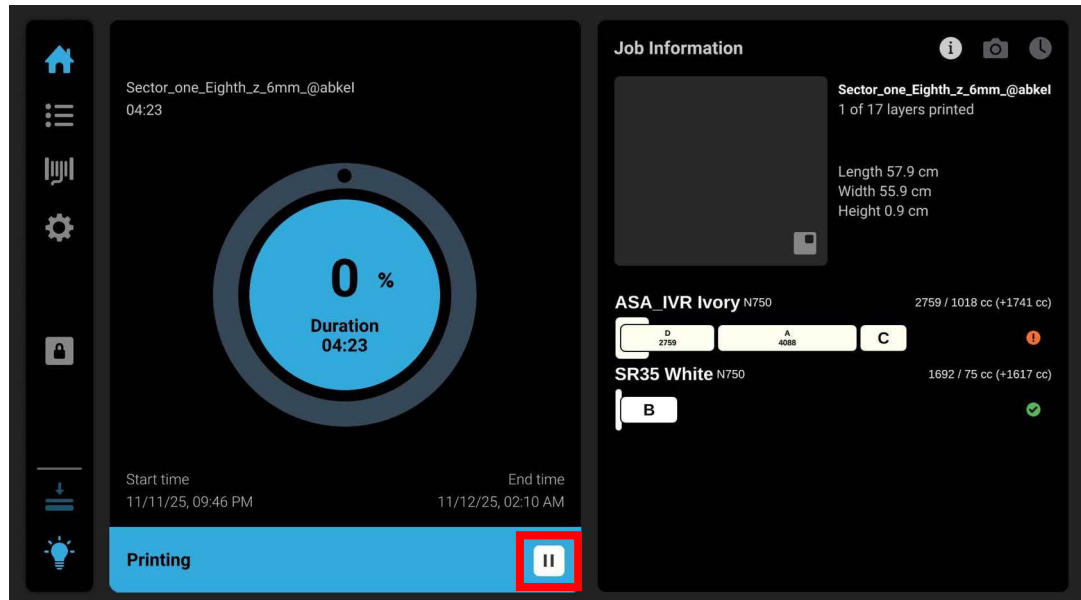
Table 12: Tool Light Display States

Color	Status	Description
None (Off)	Disabled	The tool is disabled and OK to remove.
Purple Solid	Unloaded	The tool is enabled but not loaded.
Purple Flashing	Unloaded	The tool is unloading.
White Solid	Loaded	The tool is loaded, but not currently in use. (may also be disabled)
White Flashing	Loading	The tool is in the process of loading.
Blue Solid	Utilized	The tool is in use, but not in the gantry.
Green Solid	Active	The tool is in the gantry.
Amber Solid	Warning	The tool is loaded and inactive, and life exceeds warning value.
Red Flashing	Error	<ul style="list-style-type: none"> The tool is loaded and life exceeds error value The tool is plugged.
Green Flashing	Heating	The tool is coming up to temperature.
Green Flashing	Purging	The tool is extruding material as part of a purge routine.
Green Solid	Manual Extrusion	The Manual Extrude button is pressed.

Print Job Controls

The **Play** button on the Home page will now display print progress. The status display on the bottom will display **Printing** along with a pause button. Pressing **Pause** will pause the current print.

Figure 118: Print Job Controls

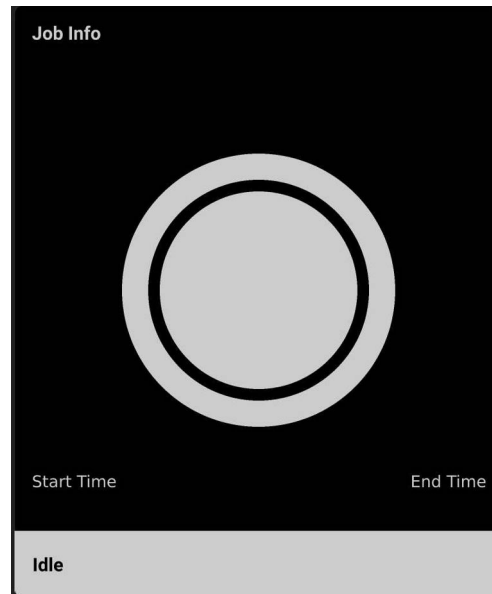


Play Button

The Play button allows you to start a build (see “Starting a Part” (page 179) for more information). The Play button can appear in the following states:

When there is not a build job in the queue, the print button will not display and the play button will be grayed out. The status will display Idle.

Figure 119: No build job in queue



When there is a job in the queue but there is a problem, (for example no vacuum, or incorrect material for the current job) the print button is displayed but is grayed out. The status will display Cannot Start.

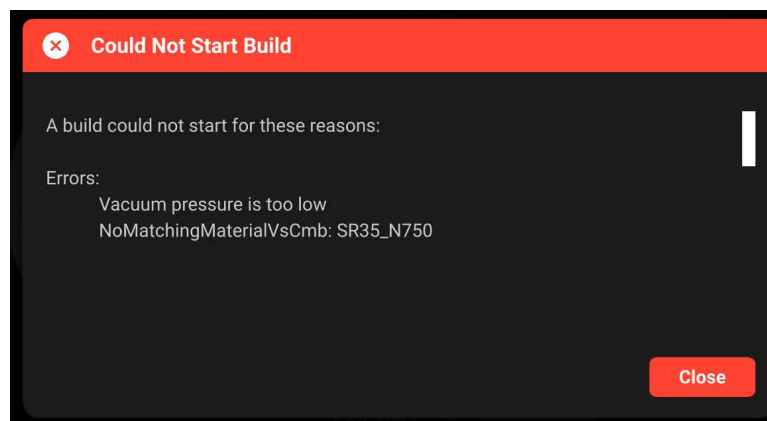


Taping the play icon will display a window detailing the conditions that must be addressed before printing will begin.

Figure 120: Job in queue with problem

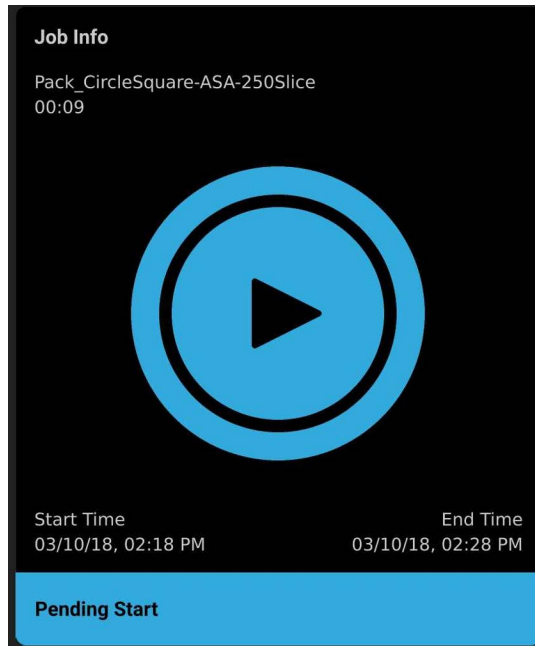


Figure 121: Problem message



When a job is selected and everything is ready, the print icon is blue and the status will indicate Pending Start.



Figure 122: Start



Pause Button

The Pause button allows you to pause an active build. The Pause button can appear in the following states:

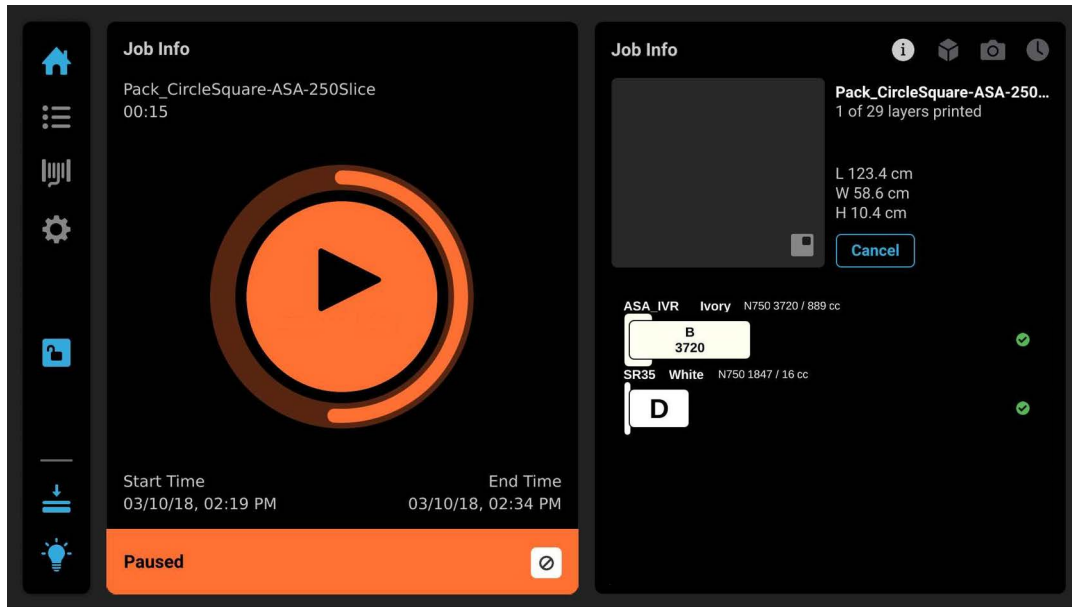
Table 13: Print Job Controls - Pause Button States

Button State	Description
	<ul style="list-style-type: none"> Printer is actively building. Selecting the Pause button in this state will pause the build. When the printer is paused, "PAUSED" is displayed within the Build Status Display.
	<ul style="list-style-type: none"> Printer is paused. Selecting the Play button will resume the build. If the build was automatically paused as the result of an error, a notification will be indicated on the screen. Touching the notification text displayed will provide additional details pertaining to the current build state. See "Warnings and Errors" (page 236) and "Build Pause Warnings" (page 238) for more information.

Cancel Button

The Cancel button allows you to abort an active build. The cancel button displays after a build is paused.

Figure 123: Cancel button



Working with the Queue Page

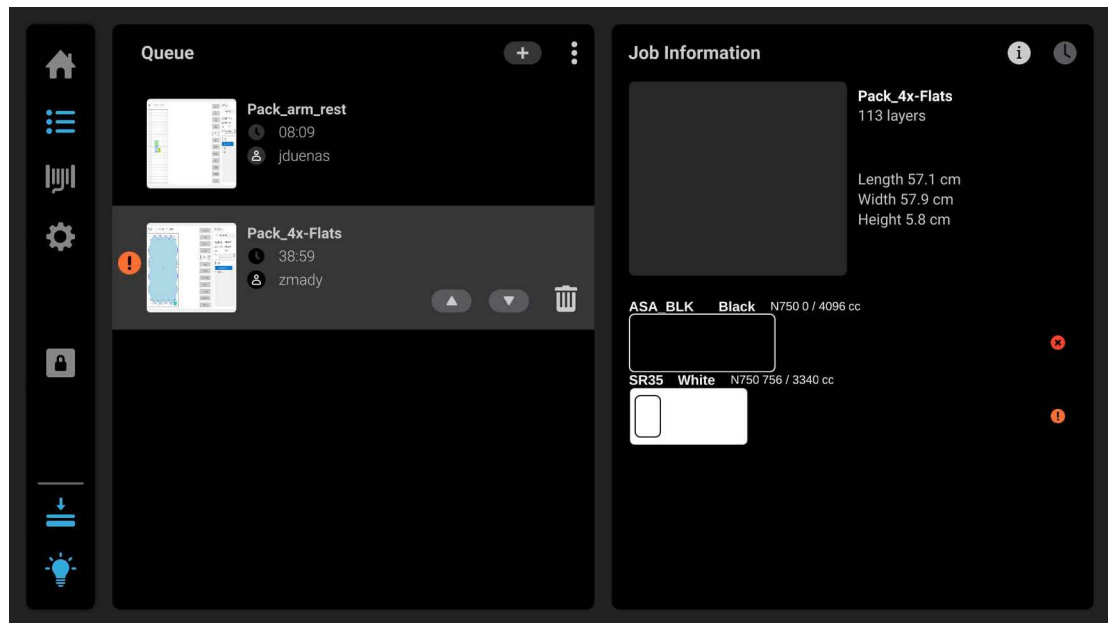
The Queue page contains the list of files (jobs) which have been downloaded to the printer and are queued for building; this list is referred to as the Job Queue. By default, jobs are added to the Job Queue in the order they were sent to the printer via GrabCAD Print and/or transferred from a USB flash drive. Individual jobs are listed in numbered rows with row one corresponding to the first job in the Job Queue. Each row displays the name of the job, estimated build time for the job, and name of the user that submitted the job. From the Queue page you can add files to the Job Queue, select a file to build, sort jobs within the Job Queue, view additional details associated with a selected job, and access the Sample Queue.

To access the Queue page, press the **Queue** button within the Navigation Menu; a screen similar to the one in

[Figure 124](#) will be displayed. Please note that the Job Queue is empty upon initial startup.

Pressing the **Edit** button within the heading of the page will display the Job Queue Control buttons; these buttons allow you to sort and /or delete the jobs within the Job Queue as needed. Pressing the **Load File** button within the heading of the page will allow you to add additional files to the Job Queue. Touching one of the rows listed within the Job Queue will open that job's Job Details page; this page contains additional information pertaining to the selected job (material configuration, tip size, etc.). After selecting either of these buttons or opening a job's details page a "Back" button will be displayed within the heading of the page; press this button to return to the main Queue page.

Figure 124: Queue Page



Adding a Job to the Job Queue

The Job Queue is empty by default. To populate the Job Queue you must first load individual job files to the Job Queue using one of the following methods:

1. Network transfer via the GrabCAD Print application on your workstation PC. See [“GrabCAD Print Method” \(page 124\)](#) for detailed instructions. This is the preferred method for adding jobs to the Job Queue.
2. Network transfer via the Insight Control Center application on your workstation PC. See [“Insight Software” \(page 100\)](#) for detailed instructions.
3. USB method via a USB flash drive inserted into the USB port on the front of the printer. See [“USB Method” \(page 124\)](#) for detailed instructions. This method can be used as a backup to the GrabCAD Print method if you are unable to transfer job files to the printer via your Ethernet connection (due to poor connectivity, a network outage, etc.). This method also provides a convenient option for you to reprint a common job, as you can store the processed job file on the USB flash drive and access it repeatedly.

GrabCAD Print Method

As part of the printer’s installation and setup process, you should have downloaded and installed the GrabCAD Print application onto your workstation PC (see [“GrabCAD Print Software” \(page 42\)](#) for details). GrabCAD Print is the software used to process job files and then transfer them to the printer (via your facility’s Ethernet connection) to be built.

Jobs are sent to the printer in CMB format and are placed directly into the Job Queue. No additional steps are required to add a job to the Job Queue when sending job files directly to the printer via GrabCAD Print. After sending the job file to the printer navigate to the Queue page by pressing the **Queue** button within the Navigation Menu. The transferred job file will be displayed within the Job Queue list. Jobs will appear within the Job Queue in the order they’re sent to the printer from GrabCAD Print. To build a specific job, that job must be listed as the first item in the Job Queue. You can sort jobs within the Job Queue as needed to select the job you’d like to print (see [“Editing the Job Queue” \(page 126\)](#) for details).

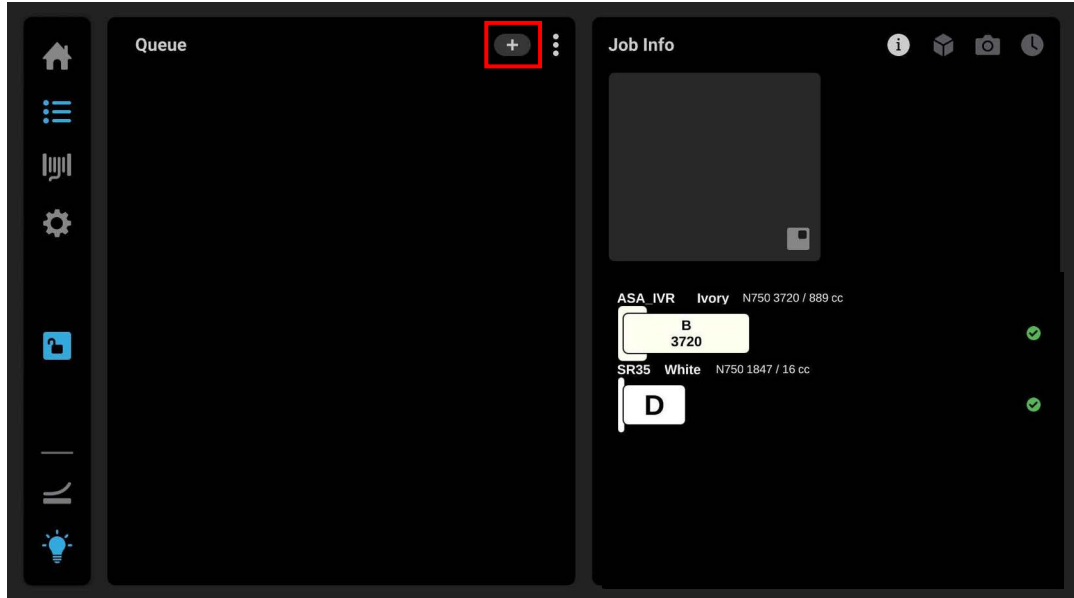
USB Method

The printer features one USB port. A USB flash drive can be inserted into the port and job files contained on the flash drive can be added to the Job Queue. Please note that job files should be processed using GrabCAD Print or Insight before they are placed onto the flash drive and subsequently added to the Job Queue. Once the flash drive is plugged into the printer’s USB port, you will need to perform the following steps to add the desired job file to the Job Queue:

1. Plug a USB flash drive into one of the available USB ports on the printer.
2. Navigate to the Queue page by pressing the **Queue** button within the Navigation Menu.

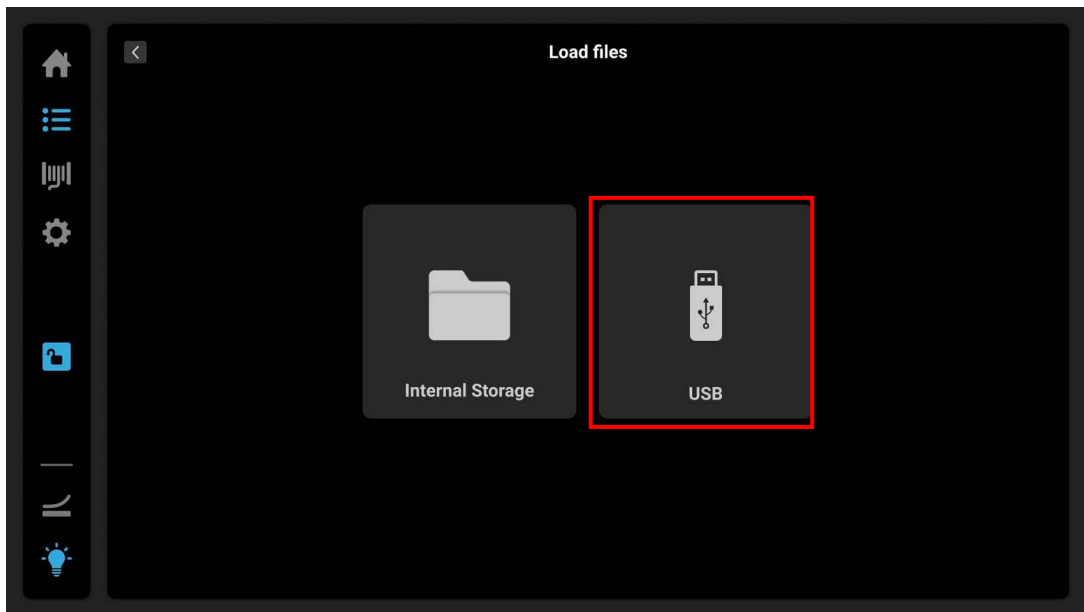
3. Press the **Load File** button in the upper-right corner of the touchscreen.

Figure 125: Load File Button Location



4. The Load File page will be displayed; press the **USB** button within this page.

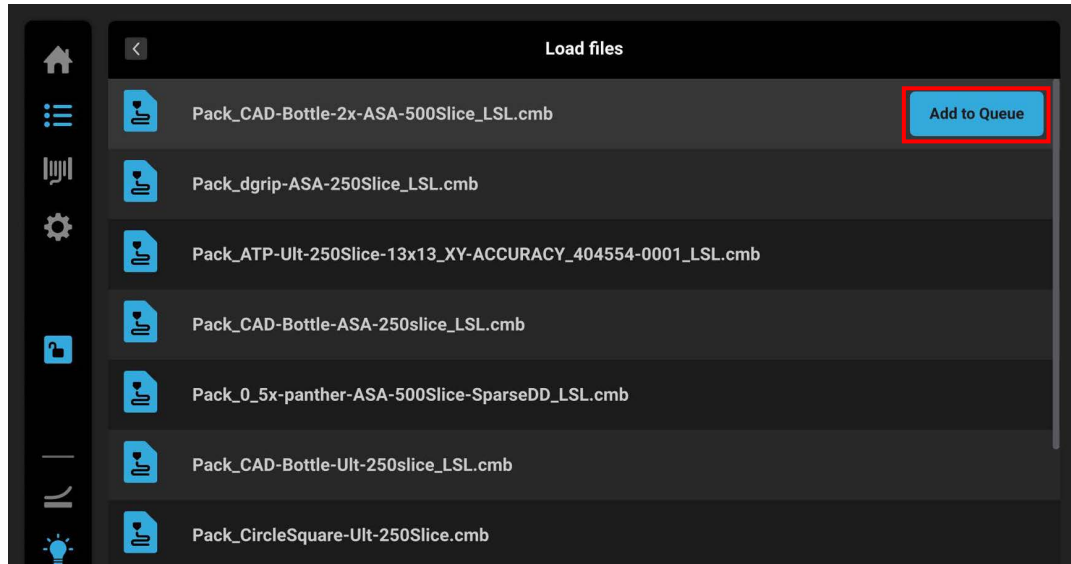
Figure 126: Load File Page - USB Option



5. The Load File page will display the contents of the USB flash drive. Locate the desired job and select it by pressing its row on the screen. Doing this will display the Add to Queue button.

- Press the Add to Queue button to add job to queue.

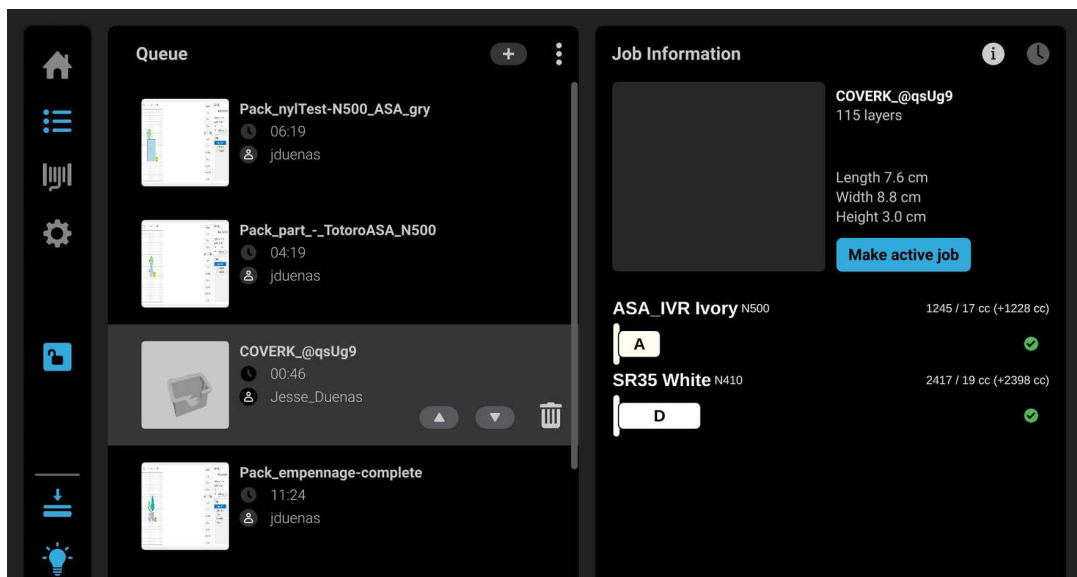
Figure 127: Select File to Load



Editing the Job Queue

By default, jobs are built in the order in which they appear within the Job Queue. To build a specific job, that job must be listed as the first item in the Job Queue. Using the Job Queue Control buttons found within this page you can sort and /or delete the jobs within the Job Queue as needed, to ensure the job you wish to build is the first item listed within the Job Queue.







Figure 128: Edit Queue Page



Job Queue Controls

These buttons will allow you to rearrange the jobs in the Job Queue as needed. These buttons have the following functionality:

Table 14: Job Queue Control Buttons

Name	Button States		Description
Move Up		Selectable	<ul style="list-style-type: none"> When selectable, moves the selected job up one position in the Job Queue list.
		Disabled	<ul style="list-style-type: none"> To move a job to the top of the Job Queue list, press this button repeatedly until the job appears at the top of the list. There is not an option to move a job directly to the top of the list.
Move Down		Selectable	<ul style="list-style-type: none"> When selectable, moves the selected job down one position in the Job Queue list.
		Disabled	<ul style="list-style-type: none"> To move a job to the bottom of the Job Queue list, press this button repeatedly until the file appears at the bottom of the list. There is not an option to move a job directly to the bottom of the list.
Delete		Selectable	<ul style="list-style-type: none"> Removes the selected job from the Job Queue list. You will not be asked to confirm this action prior to the job being deleted from the Job Queue.
Make Active Job			<ul style="list-style-type: none">

Viewing Job Details

To view additional details regarding a particular job in the Job Queue, select the desired job by touching its row on the screen. Doing so will open its Job Details page; this page displays the following:

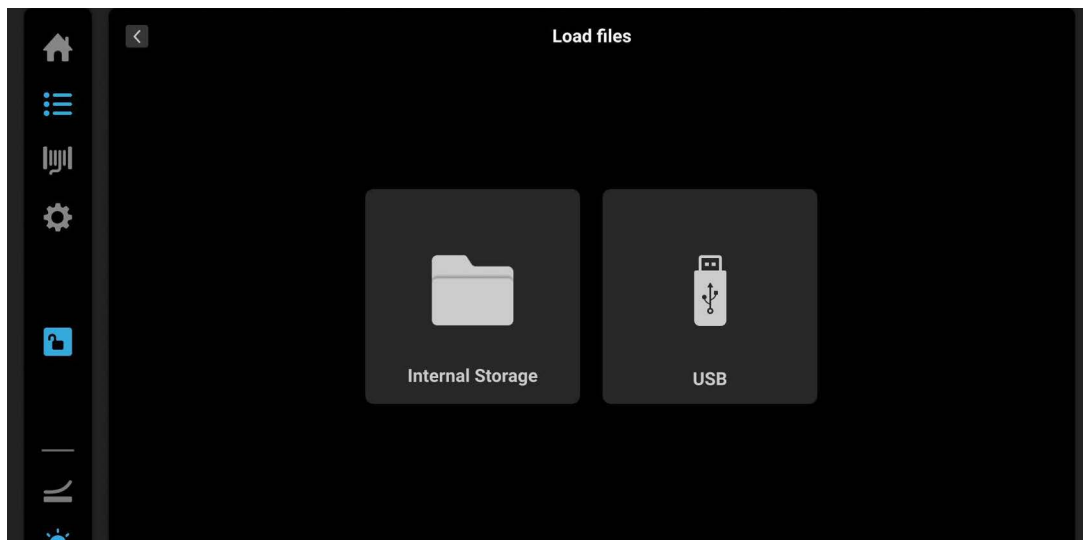
- Duration: amount of time required to complete the build.
- Author: name of the user that submitted the job.
- Materials: model and support materials associated with the job.
- Layers: number of layers in the job.
- Slice height: slice height associated with the job.

About the Sample Queue

The printer comes with several sample job files permanently installed on its hard drive. These files are accessible via the Sample Queue. This queue is composed of a few sample part files as well as a variety of other files that are helpful for testing the printer. The majority of the files within the Sample Queue will be utilized only by authorized service representatives when performing maintenance on the printer. To access the Sample Queue:

1. Navigate to the Queue page by pressing the **Queue** button within the Navigation Menu.
2. Press the **Load File** button in the upper-right corner of the touchscreen (see [Figure 125 \(page 125\)](#) for button location).
3. The Load File page will be displayed; press the **Internal Storage** button within this page. The list of sample jobs contained within the Sample Queue will be displayed.

Figure 129: Load File Page - Internal Storage Option



Overall, the functionality of the Sample Queue is the same as that of the Job Queue:

- Additional details for a job can be viewed by opening its Job Details page.
- Within the Job Details page you can view the specifics of the job including build time, author, material requirements, number of layers, slice height, and Insight version that the job was compiled with.
- Pressing the Zoom In button within the page will provide a detailed view of what the job will look like once it has been successfully built. Pressing the Zoom Out button will close this view and return you to the Job Details page.
- Pressing the Print button within the Job Details page will select the job for building.

However, the following functionality differences exist for the Sample Queue:

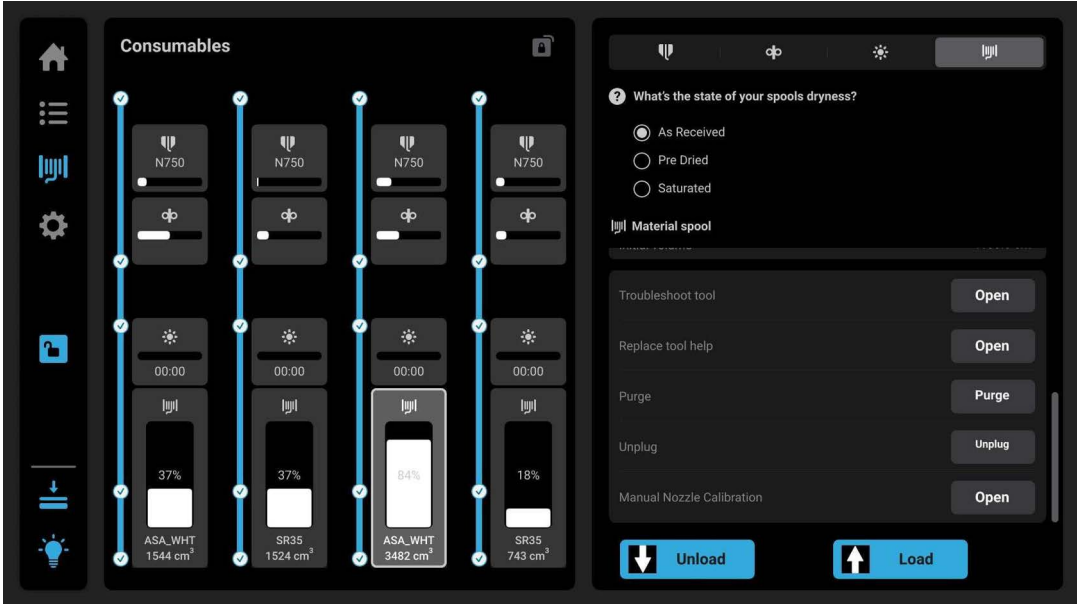
- “[Job Queue Controls](#)” ([page 127](#)) are disabled for the Sample Queue, and therefore these job files cannot be deleted.
- Jobs in the Sample Queue cannot be sorted (as described in “[Editing the Job Queue](#)” ([page 126](#))).

Working with the Consumables Page

The Materials page displays a detailed representation of the printer's current materials configuration. Within this page you can view the printer's current materials configuration including material types and colors, view material volumes and load statuses, load and unload materials, view current tool temperatures, and perform a variety of tool related maintenance functions.

To access the Consumables page, press the **Consumables** button within the Navigation Menu; a screen similar to the one in [Figure 130](#) will be displayed.

Figure 130: Consumables Page

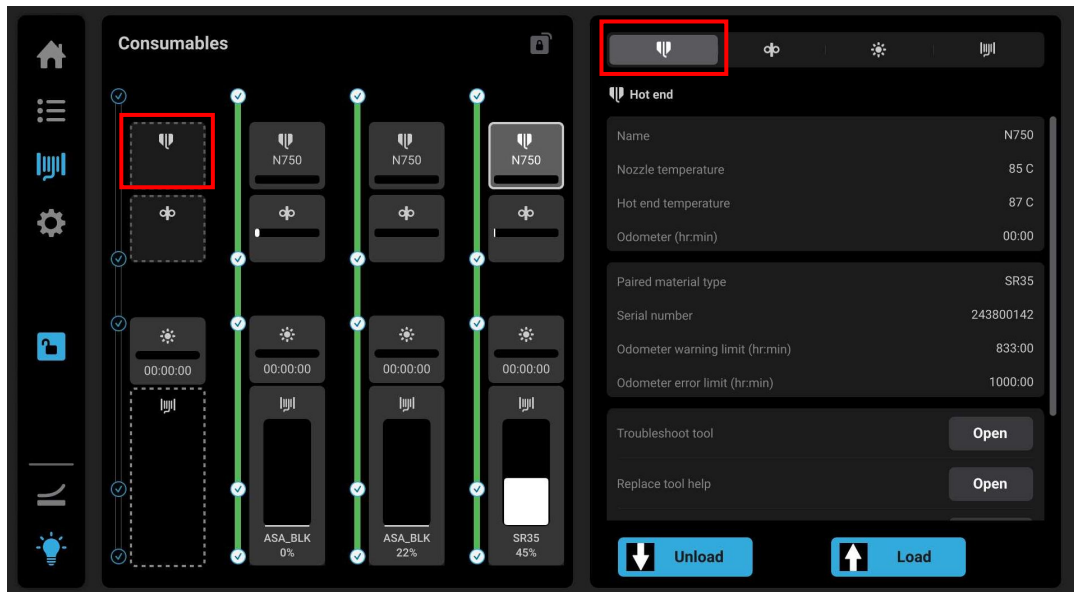


Four filament paths are displayed. Each path display begins with the material loaded to the installed hot end and the state of the filament in the printer. Each item in the filament path can be selected either directly or at the top right side of the Consumables menu. When a Hot End, Extruder Drive, Dryer bay or Material is selected, information such as temperature, odometers, and serial number is displayed. Options to load or unload, troubleshooting tools, or help menus are included to aid in replacement of tools. Press the Home button to return to the main Materials page.

Viewing Hot End Details

To view additional details about the different hot ends installed in the printer, select the desired hot end by either touching the Hot End icon in the filament path section or by touching the top right side icon labeled **Hot End**.

Figure 131: Hot end details



The right portion of the screen displays status information pertaining to the selected hot end:

- **Name:** Displays the name of the hot end.
- **Lower Temp:** Displays the current temperature.
- **Upper Temp:** Displays the current temperature.
- **Odometer (hr:min):** Displays the hot end usage.
- **Type:** Displays the hot end type.
- **Serial number:** Displays the hot end serial number.
- **Odometer Warn limit (hr:min):** Displays the set warning limit for the selected hot end.
- **Odometer error limit (hr:min):** Displays the set limit for the selected hot end.
- **Troubleshoot tool:** Selecting the **Open** icon displays a menu with images that aid in fixing hot end related issues such as clogged extruders.
- **Replace Tool Help:** Selecting the **Open** icon displays a menu with images that aid in replacing a hot end and or extruder.
- **Load:** Selecting the **Load** icon heats up the hot end and purges material.
- **Unplug:** Selecting the **Unplug** icon will perform a purge using special unplug parameters.

Selecting the **Unload** icon will first heat the hot end and then unload the filament from the hot end. The **Unload** icon then changes to **Retract**. If replacing the hot end or drive, select the **Load** icon after completion to load the filament into the tool.

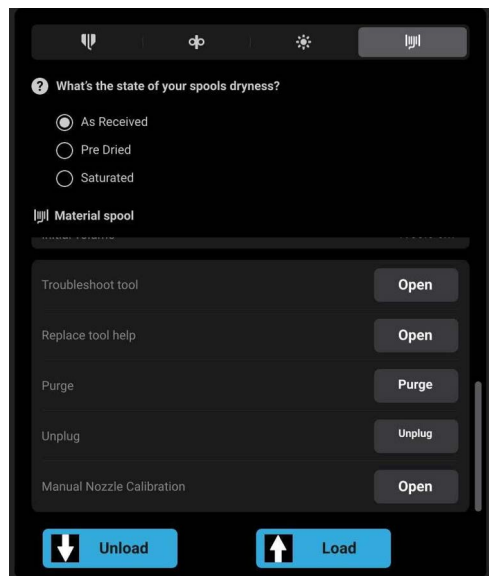
Material Status Icons

The Material Status Icons within the Consumables page represent the model and support material spools loaded in the printer. Colored bars indicating the color of the material currently installed, the name of the material currently installed, and a percentage indicating the current volume of material on that material spool. Touching one of these icons on the screen will open that material's detail on the right side of the menu.

Viewing Material Details

To view additional details regarding a particular material, select the desired material by either pressing the appropriate material icon on the screen, or by selecting the material icon on the top right side of the appropriate active filament tool path.

Figure 132: Selected Consumables highlighted



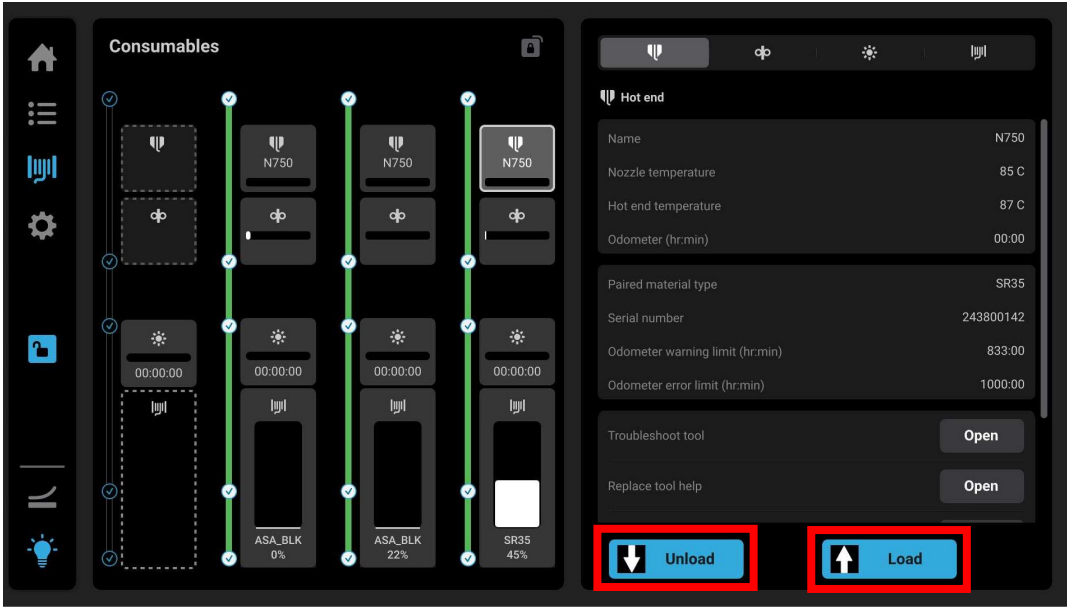
The right portion of the screen displays detailed information about the material pool including:

- **Spool Dryness State:** Provides options to select for the state of the spool being inserted.
- **Display Name:** Displays the type of the loaded material.
- **Color:** Displays the color of the loaded material.
- **Filament Position:** Displays the filament status.
- **Filament Action:** Displays current state of the filament, such as **idle** or **loaded**.
- **Mfg Date:** Displays date of manufacturing for material loaded.
- **Mfg Lot:** Displays the spool manufacturing lot.
- **Serial number:** Displays spool serial number.
- **Current volume:** Displays current volume of the spool.
- **Initial volume:** Displays initial volume of spool when it was loaded into the printer.

Material Load Controls

The Material Load Control buttons are used to load and unload material to the hot ends. The Material Load Control buttons are displayed in the lower-right portion of the Consumables page; however, the visibility of these buttons is dependent upon the material states.

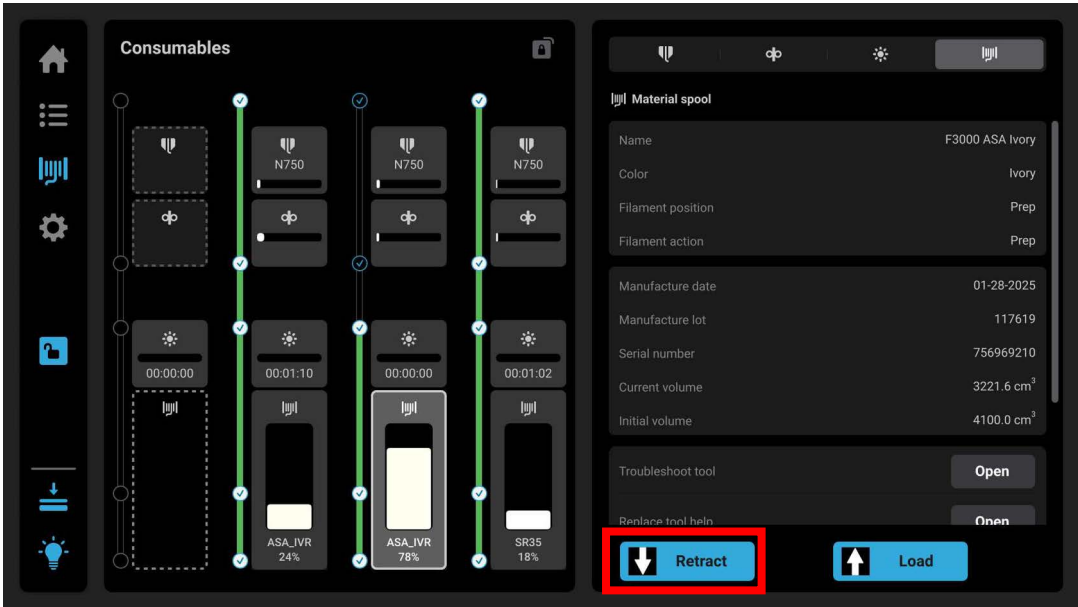
Figure 133: Material Load Control Buttons



Pressing the **Load** button when material is loaded will, after the hot end heats, purge material from the hot end. Pressing **Load** when material is unloaded will load the selected material to the drive, to hot end, and then purge material. See [“Loading Material into the Tool”](#) (page 158).


Pressing **Unload** will heat the hot end to the appropriate temperature, and then reverse the drive wheels to remove the filament from the hot end and drive. The **Unload** button will then change to **Retract**.

Figure 134: Unload complete and Retract button displayed



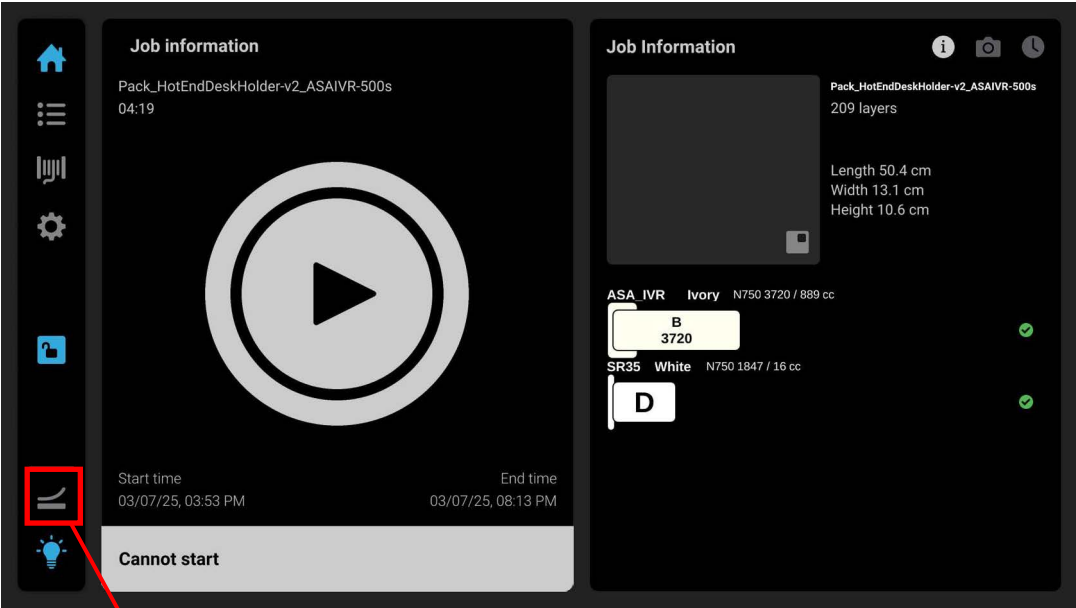
Press **Retract** to remove the filament from the printer. See “Unload Material from the Tool” (page 163).

Platen Vacuum Control

 The system cannot be in Energy Save mode while stabilizing the build sheet.

The F3300 printer uses a vacuum system to hold down the build sheet. Achieving vacuum is required before building a part can begin. After installing a new build sheet, vacuum must be re-enabled using a button located on the UI. See [Figure 135 \(page 134\)](#).

Figure 135: Platen vacuum button



Platen vacuum button toggles vacuum pump on/off.
Button disabled when vacuum switch is closed

When the platen vacuum icon is selected, a valve opens and provides air for vacuum. The icon changes to blue unsecured while vacuum is achieved. See [Figure 136 \(page 134\)](#).

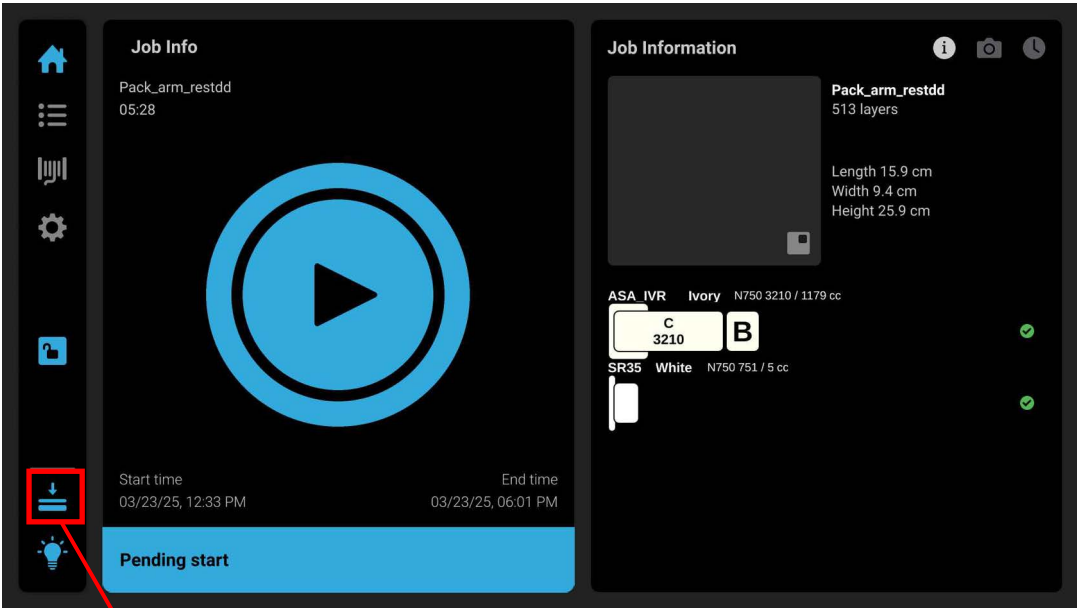
Figure 136: Vacuum enabled, but not achieved




Platen vacuum enabled, but not achieved

When vacuum is achieved, the icon will change to two flat lines colored blue. See [Figure 137](#) (page 135).

Figure 137: Vacuum on and achieved



Platen vacuum enabled and achieved

 The platen vacuum system icons are displayed as follows: A grey icon indicates that vacuum off. A blue icon indicates that vacuum is on. A blue icon with two flat lines, as shown in Figure 37 indicates vacuum is achieved and building may commence.

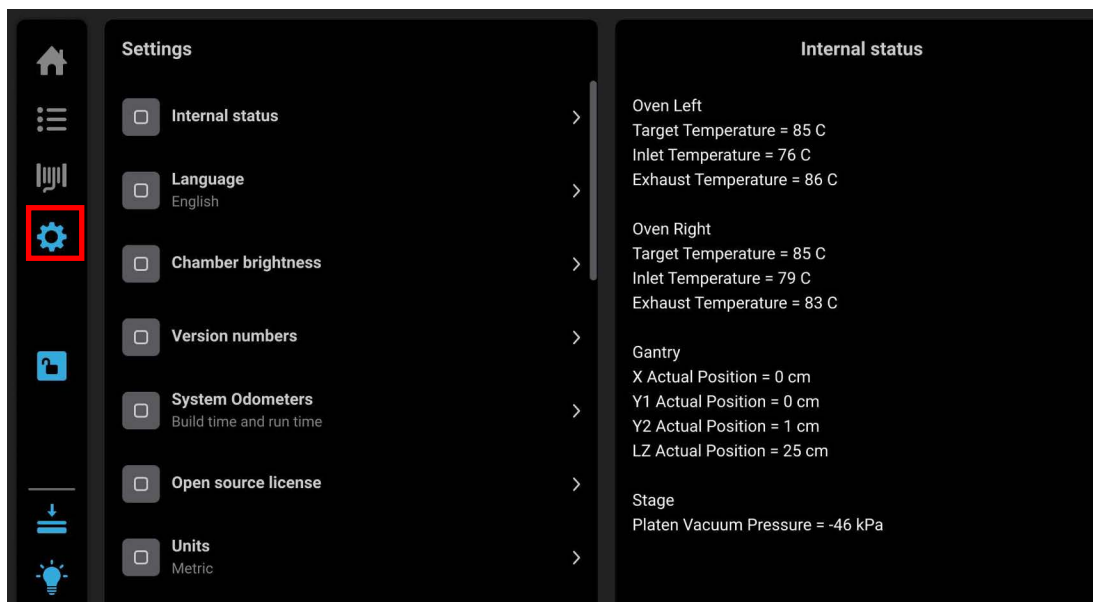
Working with the Settings Menu

The Settings menu is comprised of multiple options menus as well as a few information menus. Some options include the ability to select language, set chamber brightness, set energy saver mode, select the units, and other items. Other options give information such as software version numbers and odometer readings.

Within this page you can turn a variety of printer settings on/off (including part placement, standby mode, etc.), select your printer's address type (dynamic or static), adjust the brightness of the oven light. As a part of its initial installation and setup (performed by your authorized service representative) your printer's network settings will be configured within this page (as described within "[Configuring the Network](#)" (page 83)). Once those settings are configured you may need to occasionally access this page in order to adjust printer preferences.

To access the Settings menu, press the **Settings** icon within the Navigation Menu; a screen similar to the one in [Figure 138](#) will be displayed.

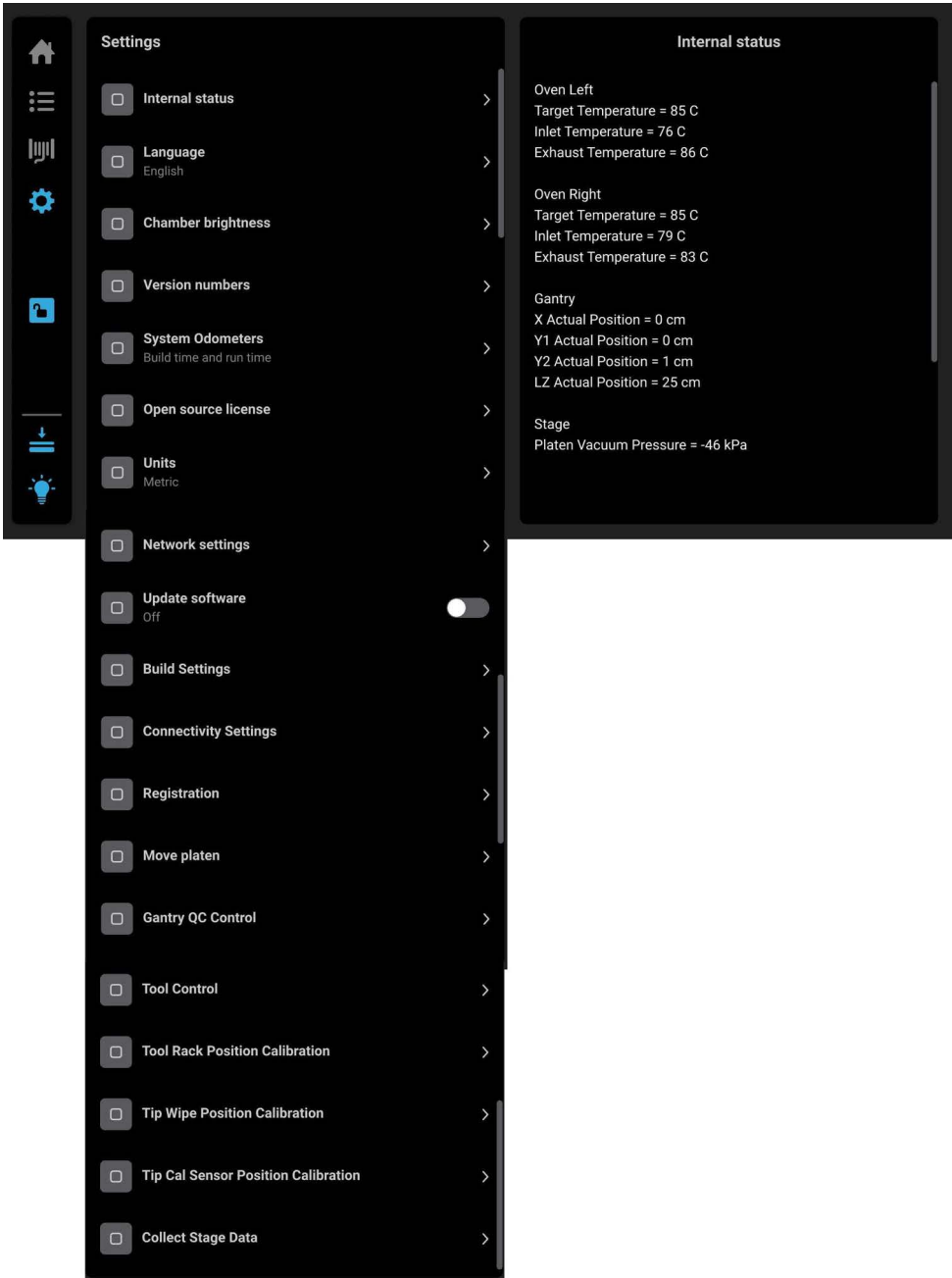
Figure 138: Access Settings menu



Settings Menu

The Settings menu contains the configuration options shown in [Figure 139 \(page 137\)](#). Selecting any of these options displays relevant information or the selection on the right side of the menu. In [Figure 139](#), the **Language** option is selected and displays the available languages. Select a preferred language.

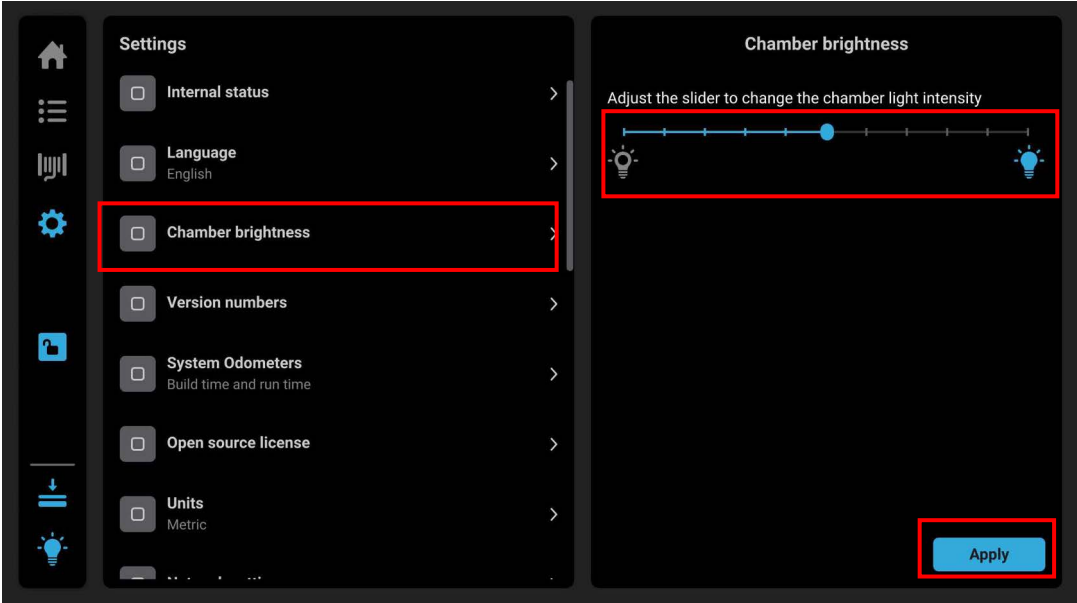
Figure 139: Settings menu



Chamber Brightness

Selecting **Chamber Brightness** displays the Chamber Brightness menu. Position the fader to the desired chamber brightness and select **Apply**.

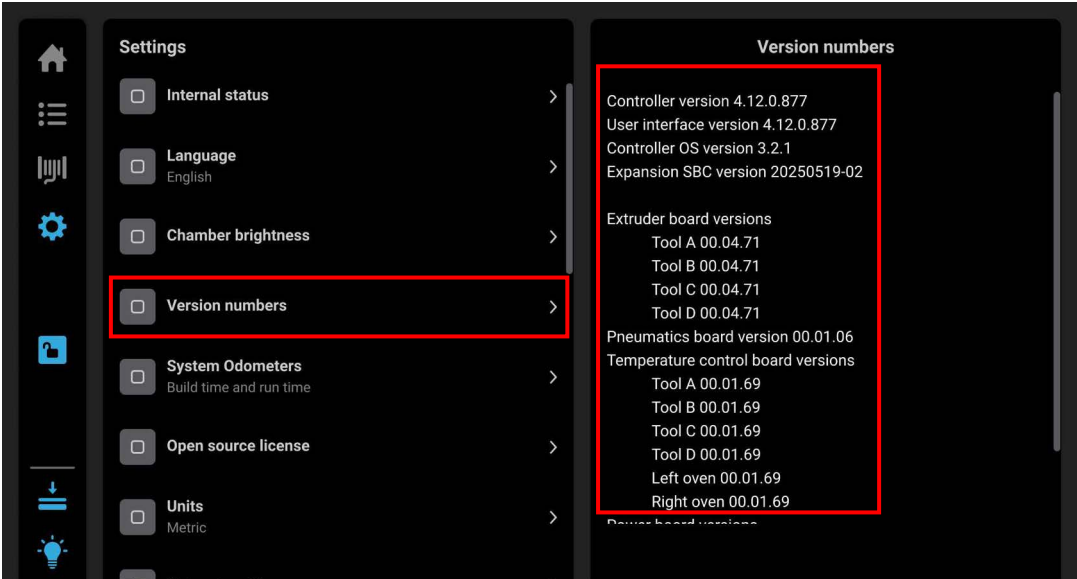
Figure 140: Chamber brightness



Version Numbers, System Odometer, and Open Source

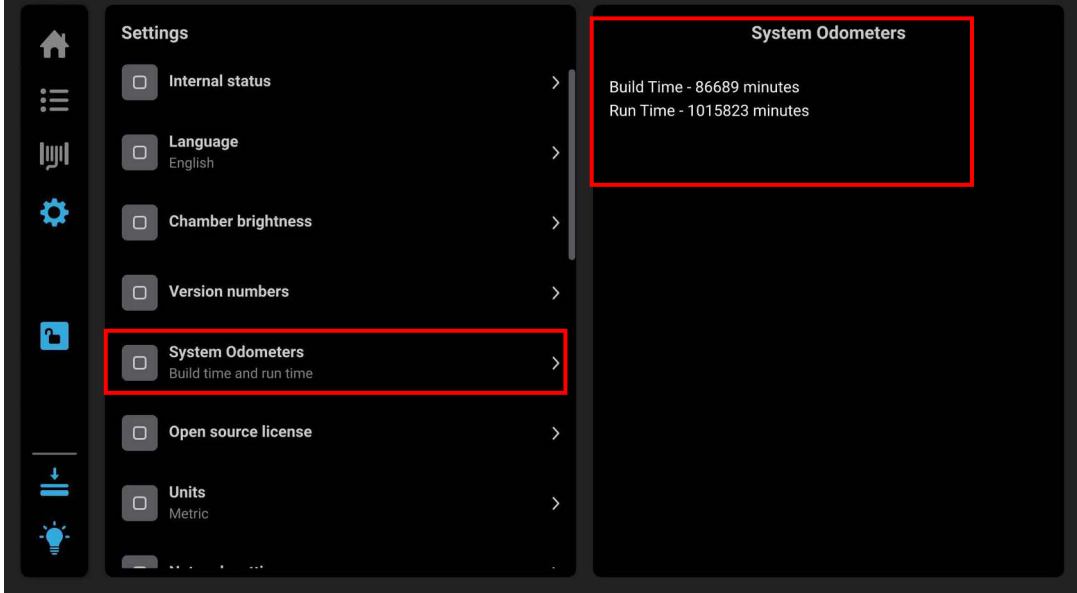
These sections contain information about the printer such as software version and material use. When working with customer service, it may be necessary to relay printer software version information. In the **Settings** menu, select the **Versions Numbers** option. The software version information displays on the right side of the menu.

Figure 141: Version Numbers screen



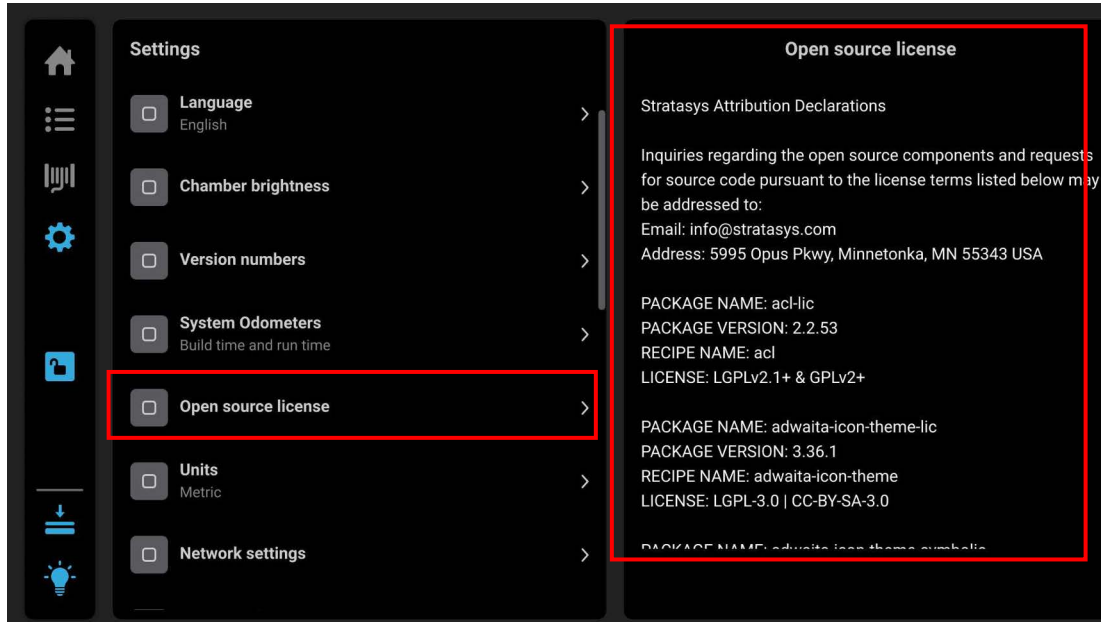
System Odometer displays information on printer use.

Figure 142: System Odometer screen



Open Source displays the printer open source license information.

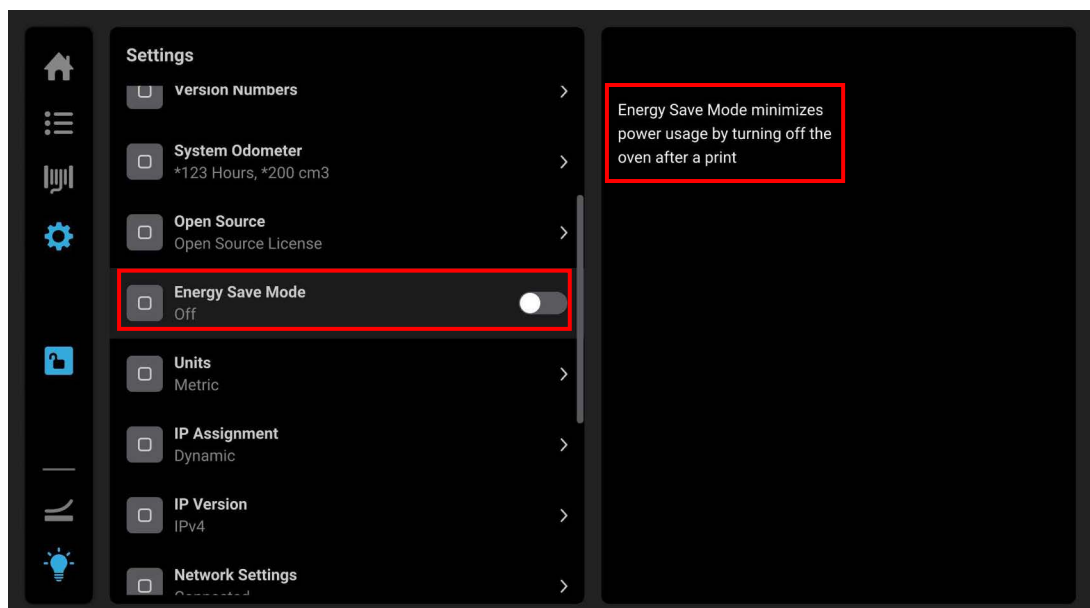
Figure 143: Open Source screen



Energy Saver

Selecting **Energy Saver** in the **Settings** menu displays a feature description as well as an **ON** or **OFF** toggle button.

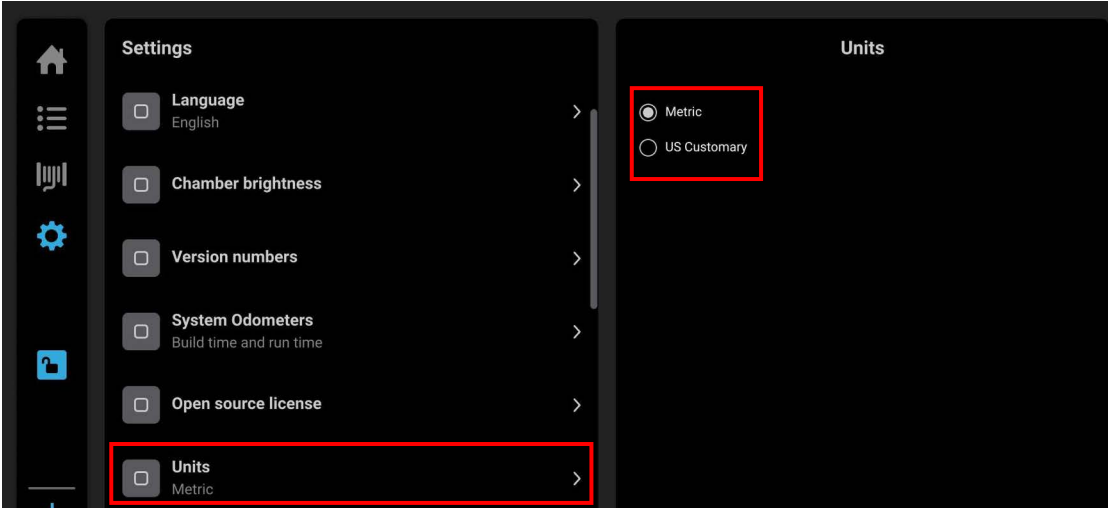
Figure 144: Energy Saver toggle button



Units

Select **Units** in the **Settings** menu to change between Metric and English units.

Figure 145: Units screen

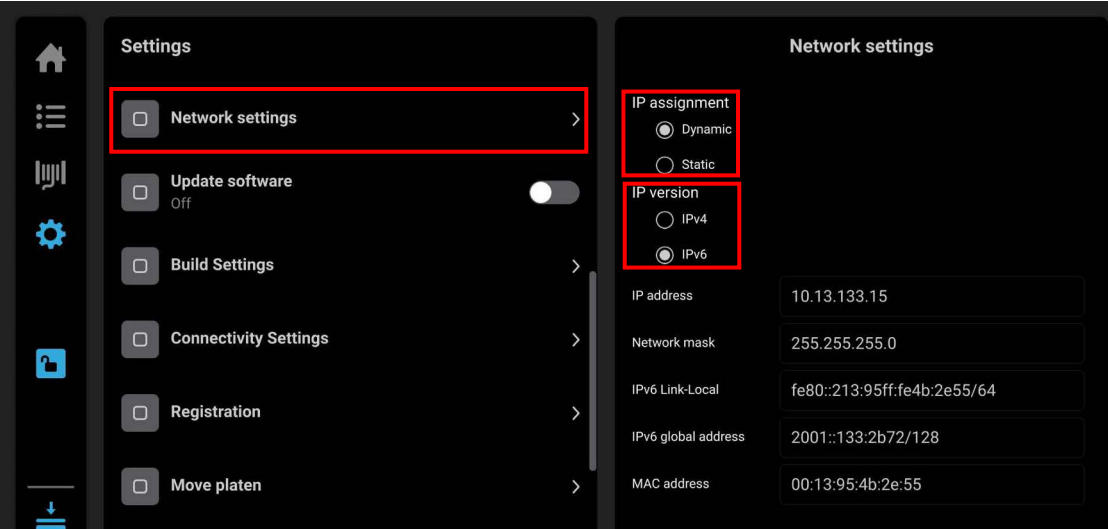


Network Settings

Selecting the **Network Settings** option displays the options for either **Dynamic** or **Static IP Assignment** and IP versions, **IPv4** or **IPv6**.

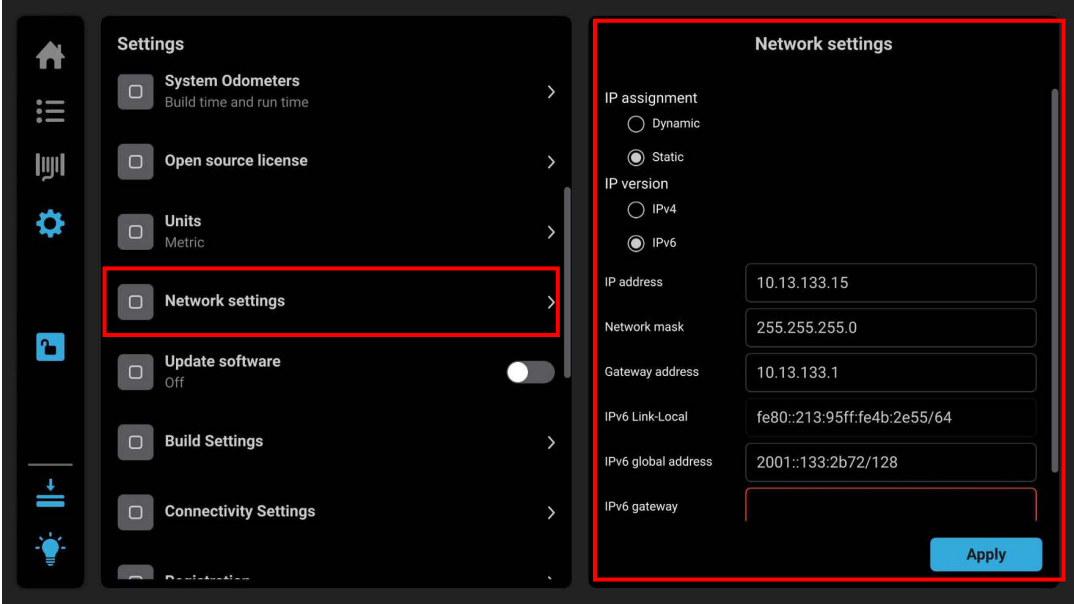
When the **Dynamic** (DHCP) network option is enabled, a network server or PC generates an IP address for the printer. A different IP address may be generated from time to time by the server or PC. The generated IP address displays within the **Network Settings** option, **IP Address** field, along with the corresponding **Subnet Mask**. The **MAC Address** information is also displayed.

Figure 146: Network Settings screen



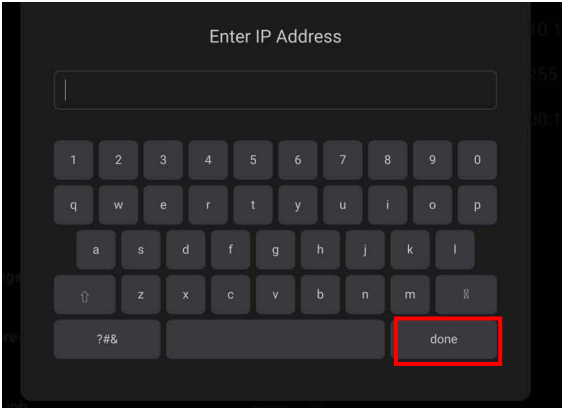
If **Static** is selected as the IP Assignment, blank boxes are displayed next to the appropriate label.

Figure 147: Static screen



Select the **IP Address** box. This displays a keyboard that is used to enter the IP address. Select **Network Mask** and **Gateway Address** next. Enter the appropriate information.

Figure 148: Popup keyboard

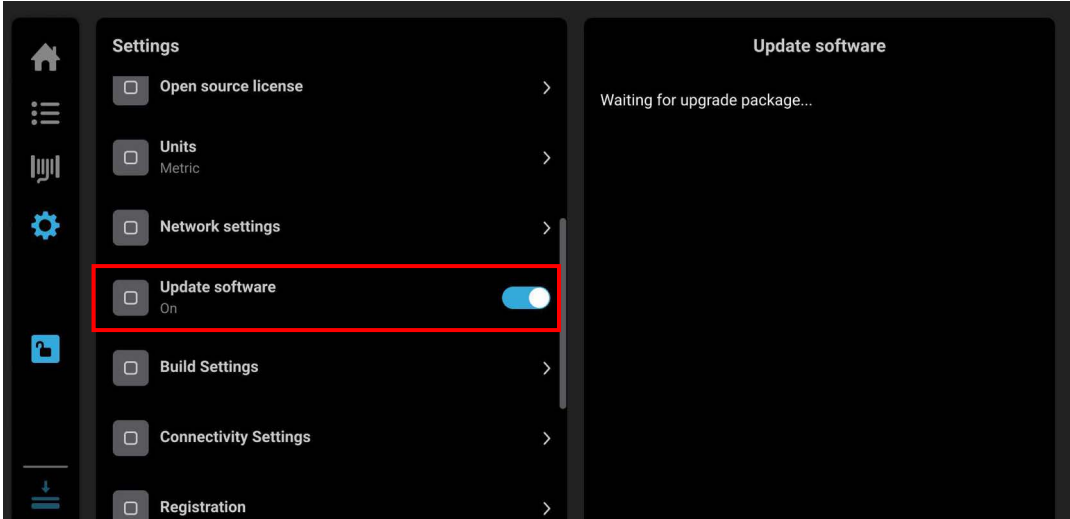


Selecting **done** or pressing cancel will return to the previous menu.

Update Software

Toggle the **Update Software** button from **OFF** to **ON**.

Figure 149: Update Software button

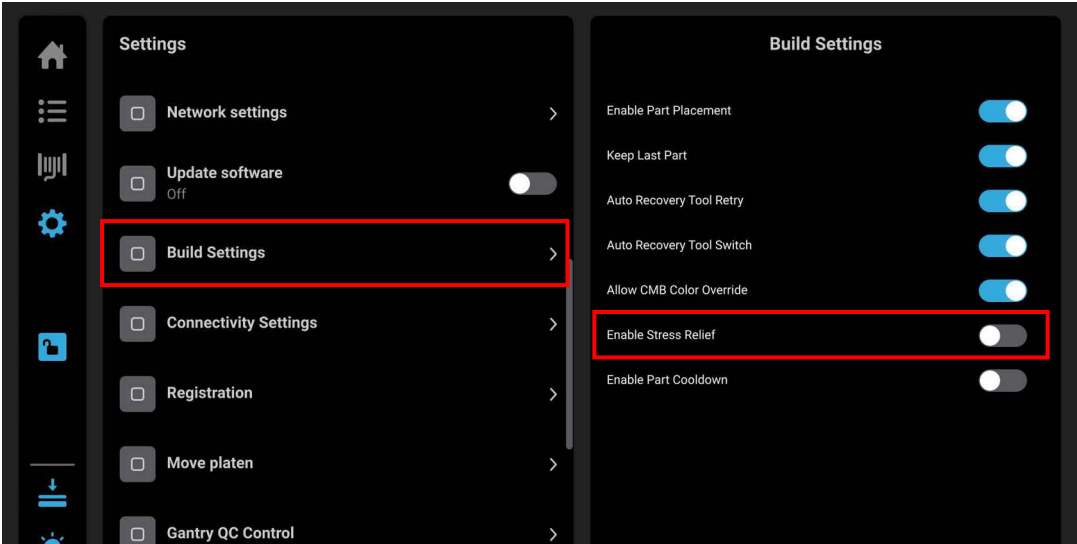


While Update Software is set to **ON**, at the workstation, select the appropriate upgrade software package and perform an update. Refer to [“Calibration and Adjustments”](#) (page 196).

Build Settings

Select Build Settings to enable and disable part placement, keep last part and various other build options.

Figure 150: Build Settings screen



Enable Stress Release

Toggle ON the **Enable Stress Release** option to reduce post part curl. The Stress Relief feature helps to stabilize the shape of some part geometries and materials that exhibit curl after removal from the printer.

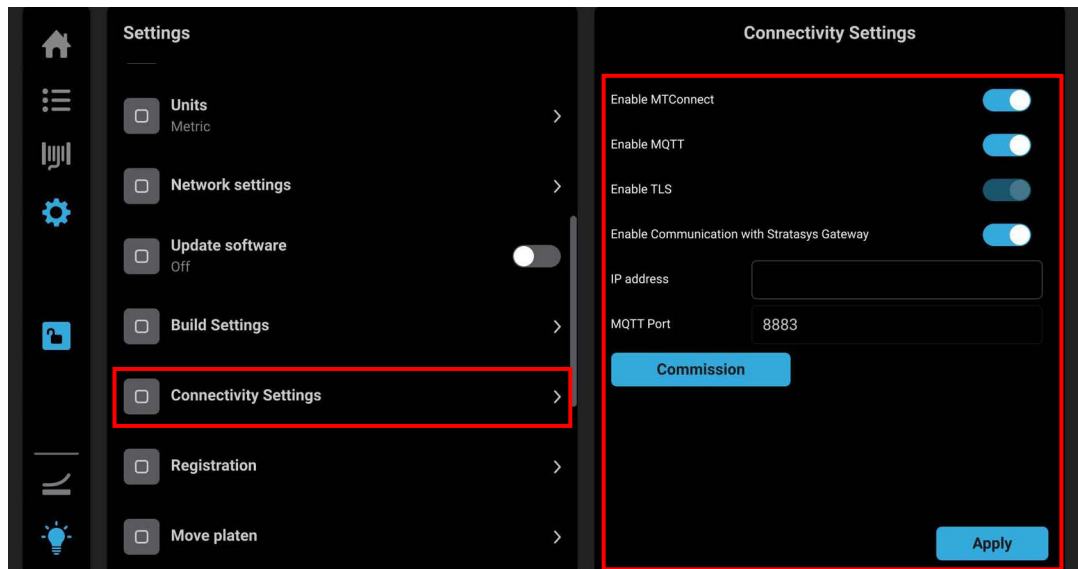
When Stress Release is enabled, the platen will remain at the top of the oven when the part is complete to allow it to soak at higher temperatures. Holding the part higher briefly can reduce the sudden temperature change that may contribute to curl. Shorter parts (35mm to 110mm) will primarily benefit from this feature. Taller parts generally will **not** benefit as they naturally transition gradually through the oven's temperature gradient.

The mode you select in Insight (Thin Wall, Normal, Brick) adjusts print behavior to balance quality and throughput for that mode. Some Post-Build Soak behavior may vary by material and mode, and it is managed automatically by the printer software. Taller parts outside the 110mm will proceed without a soak time. Soak times are typically between 5 minutes and 3 hours based on the material used and height of the part. The soak can be canceled after part completion if desired.

Connectivity Settings

Select Connectivity Settings to enable MTConnect and access gateway settings. See [“Registering and Commissioning the Printer”](#) (page 72).

Figure 151: Connectivity Settings screen



Registration

Printers must be registered with Stratasys to enable the printer. Unregistered printers will be unable to print. See [“Registering and Commissioning the Printer” \(page 72\)](#). Please contact your Stratasys regional support for more information.

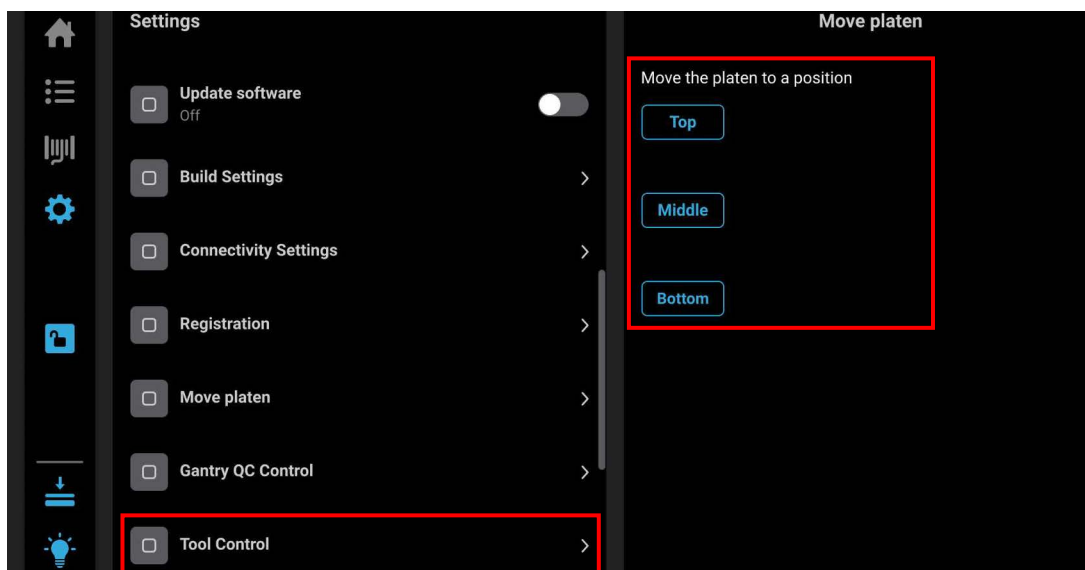
Figure 152: Registration screen



Move Stage

Selecting the **Move Stage** option displays **Top**, **Middle**, and **Bottom** touch buttons. Pressing the touch buttons moves the platen to the indicated location. This can be useful for rapidly attaining vacuum between the platen and build sheet before the start of a build.

Figure 153: Move Stage screen



6 Operating the Printer

This chapter explains basic steps in operating the printer.

Basic User Operations

Powering On the Printer



The power-on process typically takes between 3-5 minutes. The screens displayed during the power-on process may change depending on software version. What is shown below is typical.

To power the printer on:

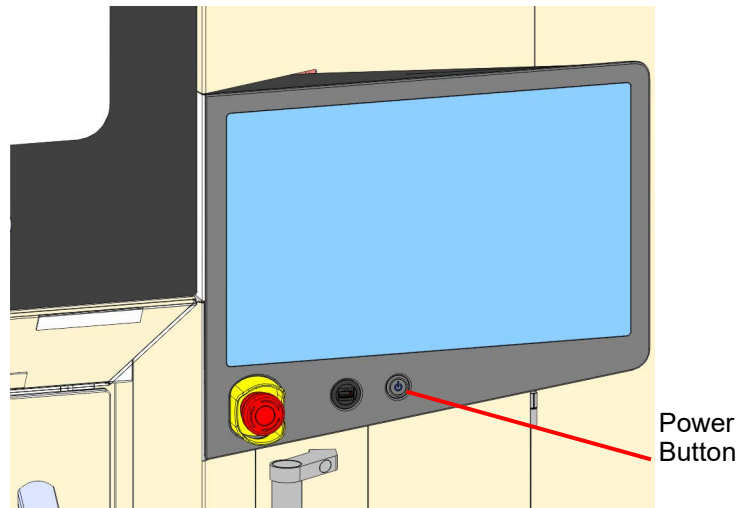
1. Ensure that the printer is properly connected to the required power source. See the F3300 Site Preparation Guide for further information.
2. Turn the electrical disconnect switch to the ON position.

Figure 154: Electrical disconnect switch in ON position



3. Press the power button located on the front of the printer. The button illuminates.

Figure 155: Power button location under screen



4. If any tools are installed, lights on the tools will momentarily illuminate in green to indicate proper installation.
5. The printer will begin to boot. The touchscreen will turn on and begin initializing.

Figure 156: Initializing start up screen



6. After approximately 3 minutes, the oven fans will begin blowing and the interlocks engage.
7. The light tower will illuminate green if the printer is ready to print, or red if there is an error. The light tower relays status as follows:

Green solid: Printer is printing. There are no issues, and no attention is required.

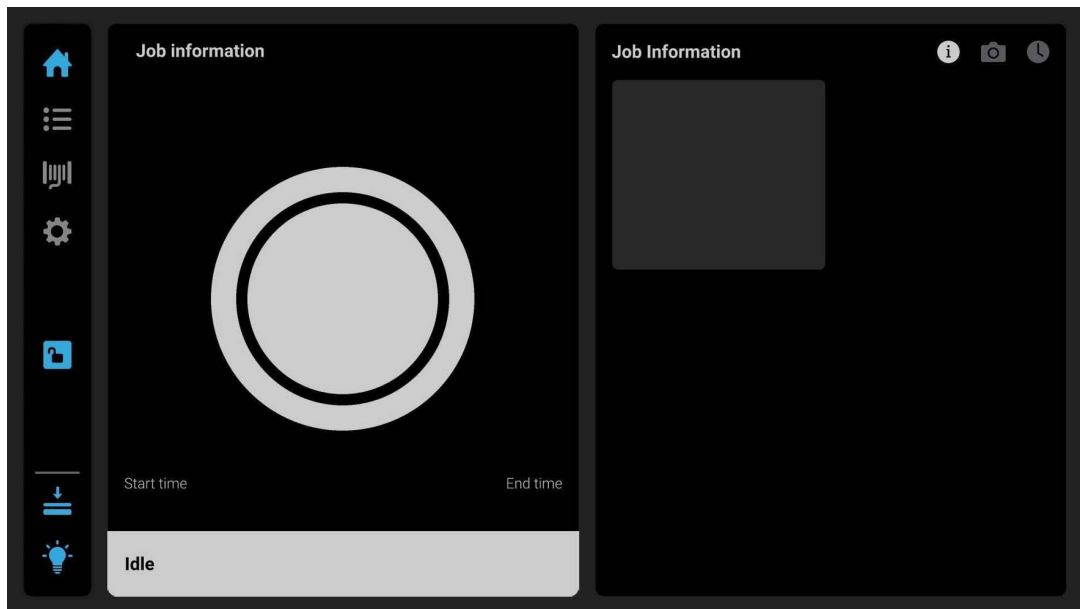
Green flashing: Printer is ready to print if a part is removed from the build chamber or if Play is pressed.

Yellow: Printer is paused and needs operator intervention to resume build.

Red: Printer is experiencing an error or a fault condition.

8. After the initialization and start up process is complete, the touchscreen will refresh to display the Home page and the printer will automatically perform an XY Gantry Homing process.

Figure 157: Home Page

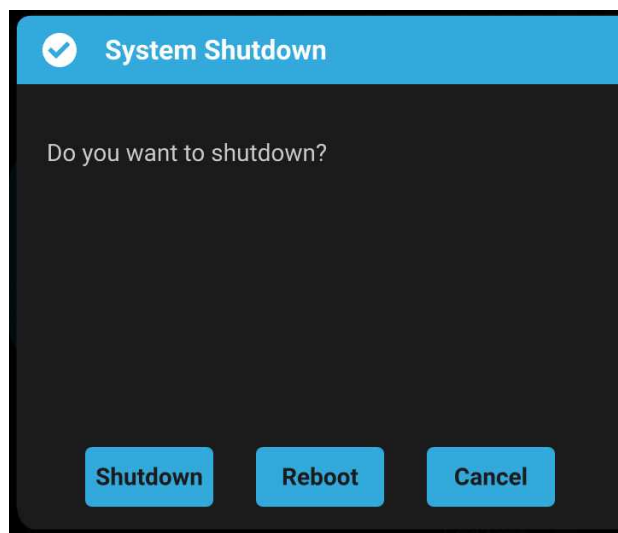


Powering Off the Printer

To power the printer OFF:

1. Ensure that the printer is stopped (idle) and is not building.
2. Press the power button located on the front of the printer (see [Figure 155](#) for button location).
3. A dialog box will display on the user interface with the following options:
 - Shutdown
 - Reboot
 - Cancel

Figure 158: System Shutdown Options



4. Select **Shutdown** to power down most, but not all, of the electronics.
5. To completely disengage power to the printer:
 - Set the electrical disconnect to OFF and,
 - If the printer is not connected directly to power, unplug the power cord located at the rear of the printer.

Figure 159: Electrical Disconnect OFF



For extended non-use periods greater than 72 hours, unload the material, store the material in an air tight bag and power OFF the system.

Installing the Extruder Assembly

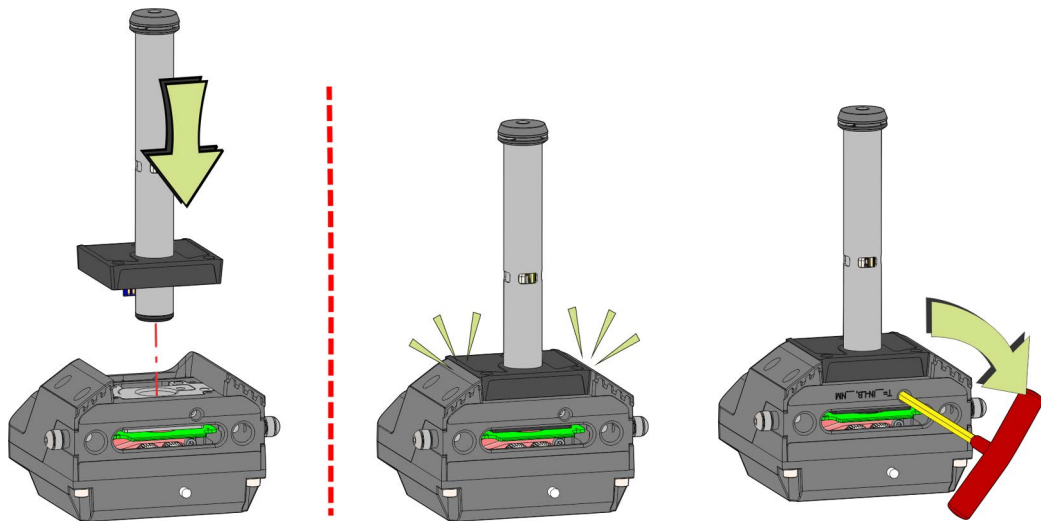
1. From the touchscreen interface, navigate to the Consumables screen.
2. Press the hood icon to unlock the hood. The icon changes from gray to blue to indicate the hood is unlatched.
3. Open the printer front gantry hood.
4. Remove the new hot end and extruder drive from their individual packaging.
5. Assemble the hot end to the extruder drive. Ensure that the connection is fully seated.
6. Use a 4 mm hex wrench to snugly fasten the captive screw securing the hot end to the extruder drive.



CAUTION: Damage to Equipment

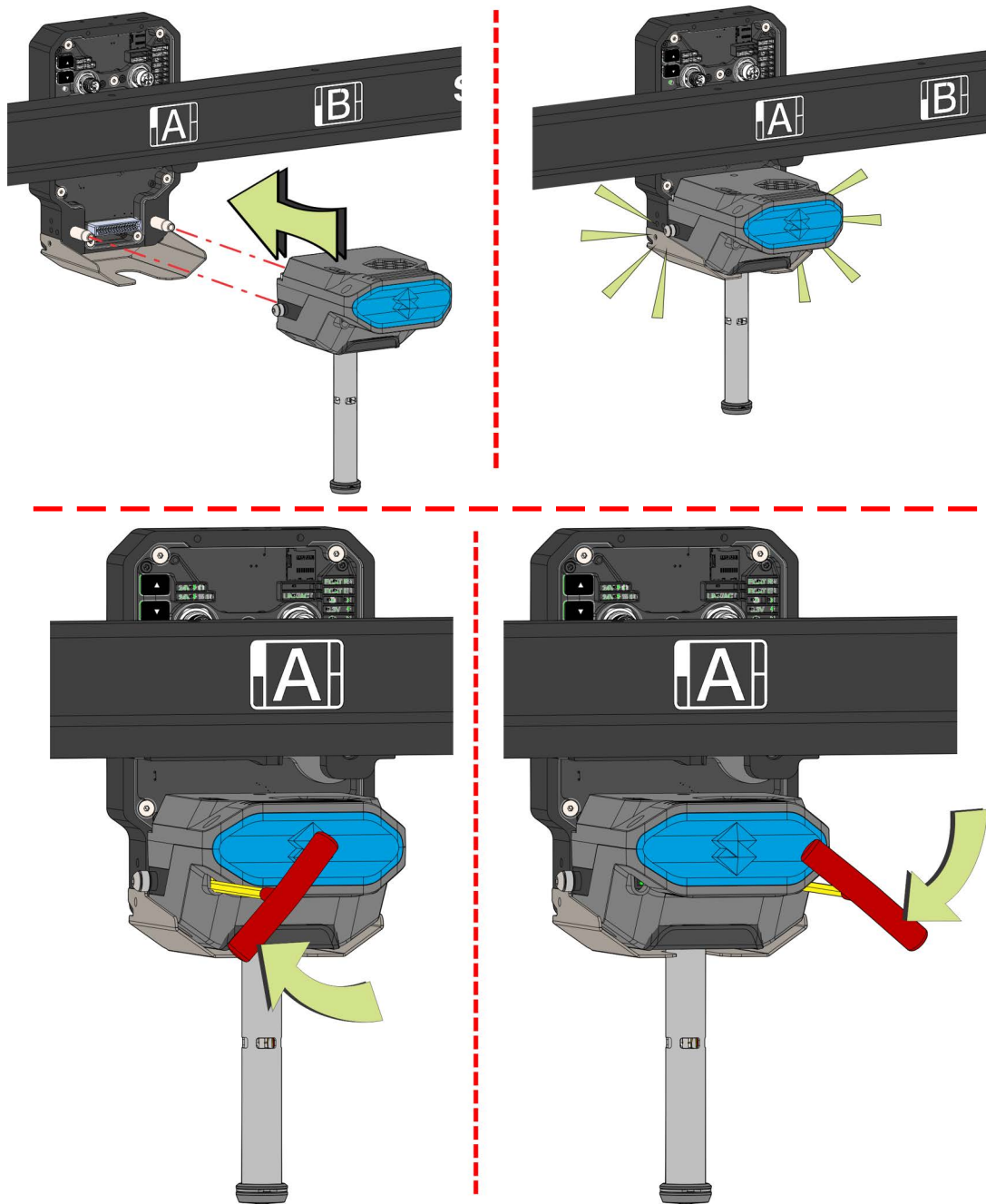
Make sure that the hot end is properly secured to the extruder drive. If the hot end is loose, system damage or print failures will occur.

Figure 160: Constructing the Extruder Assembly



7. Loosely install the extruder assembly to the two alignment pins on its designated printer extruder tool base. See [Figure 161 \(page 152\)](#).
8. Gently push in the extrusion tool assembly to ensure that it is fully seated in the tool base.
9. Use a 4 mm hex wrench to snugly fasten the captive screws (2) securing the extruder assembly to the tool base.

Figure 161: Installing the extruder assembly



10. Close the printer front gantry hood.

Loading Material

Inserting a Spool into a Material Bay



Caution: Prevent cross-winding of the material filament.

- Always keep material spools in a vertical orientation.
- Always ensure that the end of the filament is held securely so that loose wraps cannot occur.

1. Place the material spool box on a flat surface with the box label in an upright orientation.
2. Open the top of the box.

Figure 162: Opening the Upright Material Spool Box



3. Remove the top protective foam piece from the box.
4. Remove the material spool bag and bottom protective foam piece from the box.

Figure 163: Removing Material Box Contents



5. Set aside the box and protective foam pieces.
6. Use a cutter to carefully cut open the top of the material spool bag.
7. Reach into the material spool bag and use the docking handle to remove the material spool from the bag.

Figure 164: Inside the Material Spool Bag



8. Remove and dispose the desiccant bags located inside the material spool (8).



Ensure that the material spool always remains in an upright vertical orientation.

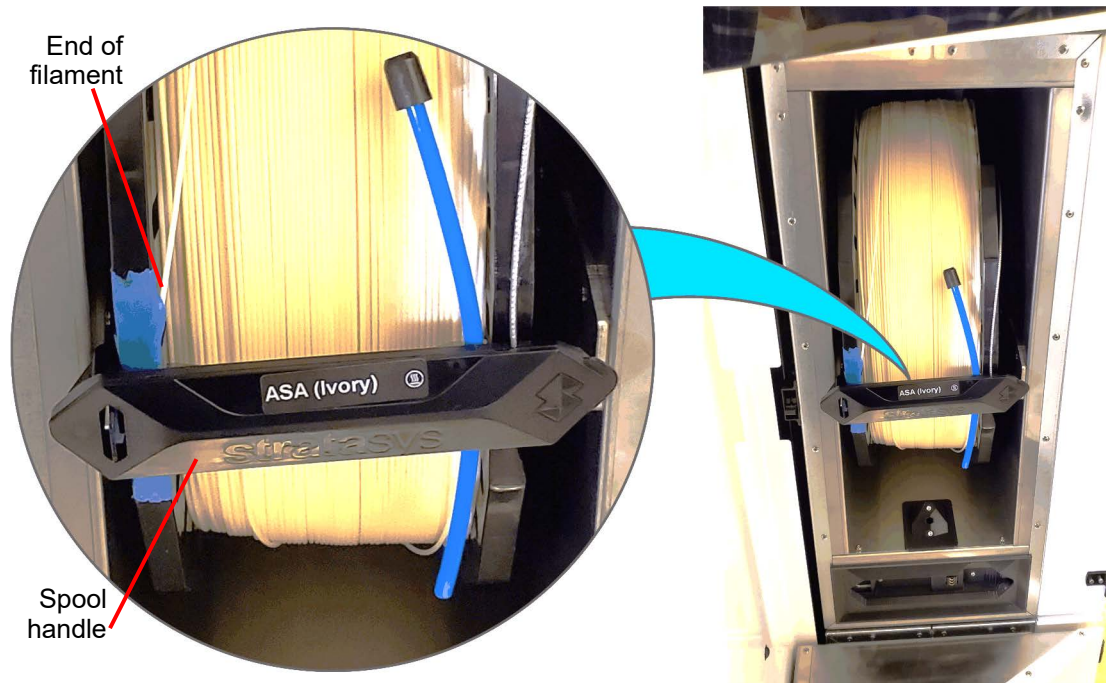
Figure 165: Removing Desiccant Bags



9. Open the material bay door corresponding to the extruder station in use.

10. Insert the spool into the material bay so that the lettering on the docking handle is in an upright orientation. The end of the filament should be secured (taped or clipped) to the spool in the front, pointing downward.

Figure 166: Material spool orientation inside material bay



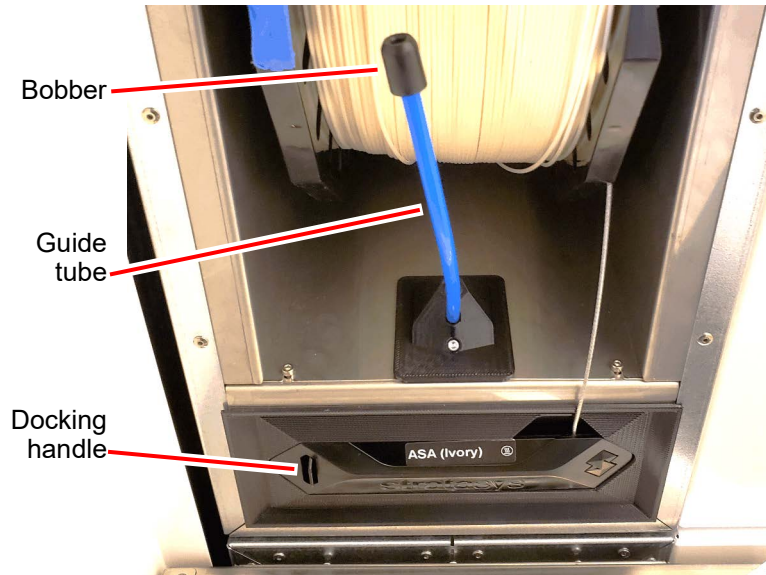
11. Push the material spool as far as far as possible into the material bay.
12. Unlatch and remove the docking handle from the front of the material spool.
13. Remove the guide tube and bobber from the docking handle.
14. Insert the guide tube into the filament receiver, with the bobber attached to the tip.



Do not lose the bobber. It is necessary to prevent cross-winding of the filament.

15. Insert and latch the docking handle into its docking position below the open material bay.

Figure 167: Guide Tube and Docking Handle Installed

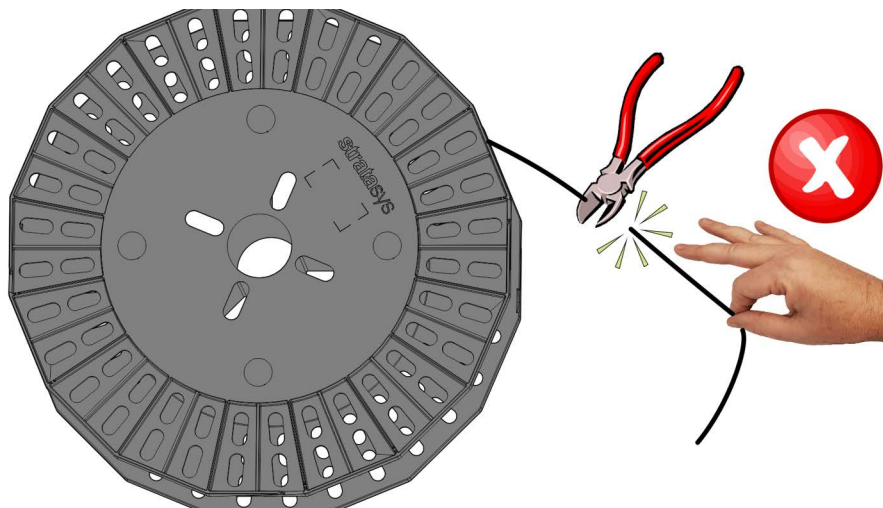


16. Remove the end of the filament from the clips on the material spool flange. Keep tension on the filament to prevent loose wraps from occurring.
17. Use a cutter to remove any filament that was wrapped over the flange. Kinks in the filament can cause high friction in the filament path and lead to a load failure.

i

- When cutting the end of the filament, ensure that the filament end is held securely and taut until it is fed into the guide tube. This prevents loose filament wraps from developing which can create spool snags.
- Cut perpendicular to the filament, not at an angle. This will prevent the filament from catching on any edges as it loads to the hot end.

Figure 168: Cutting the End of the Filament



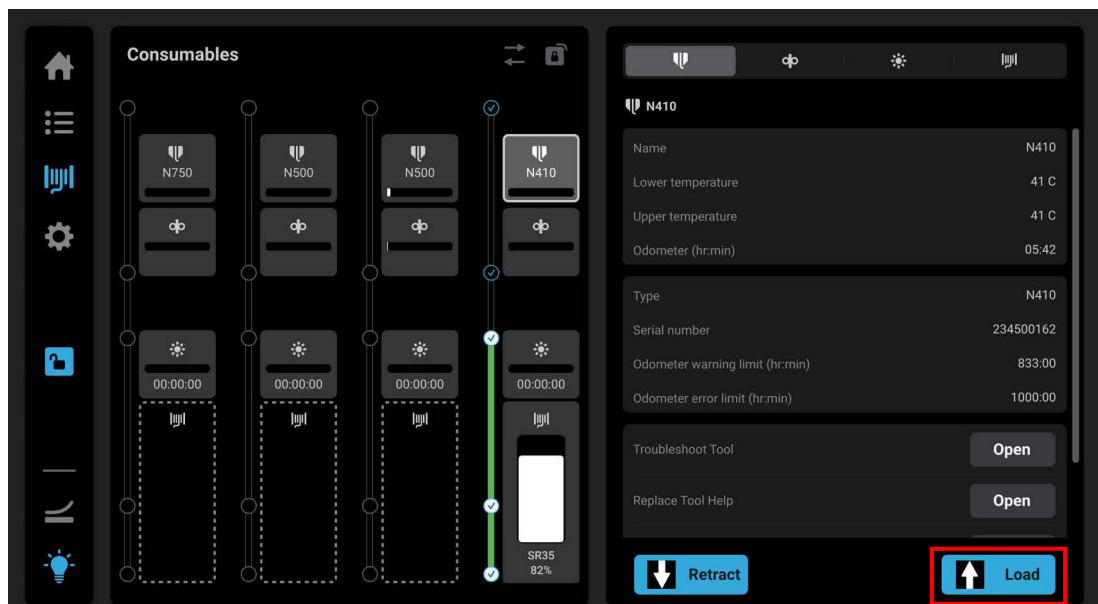
18. Insert the end of the filament into the guide tube and slowly feed it until it engages with the drive. When the drive engages, it will pull the filament approximately 40mm into the printer and stop. The filament may be left in this state to dry or may be loaded immediately to the Hot End.

Figure 169: Feeding the Filament into the Guide Tube



19. Close the material bay door.
20. From the touchscreen interface, navigate to the Consumables screen. Select the desired filament path that will be loaded by pressing on any of the components in the filament path, such as the Hot End, Extruder, Dryer Bay, or Material.
21. Press **Load**. Monitor the status of the material bay and filament as it is loaded into the printer.

Figure 170: Consumables Screen



Loading Material into the Tool

The following steps are used to load either support or model material into the tool. As the filament progresses from the material bay to the tool, the information shown on the touchscreen reflects the status of the material loading process.

To load material into the tool:

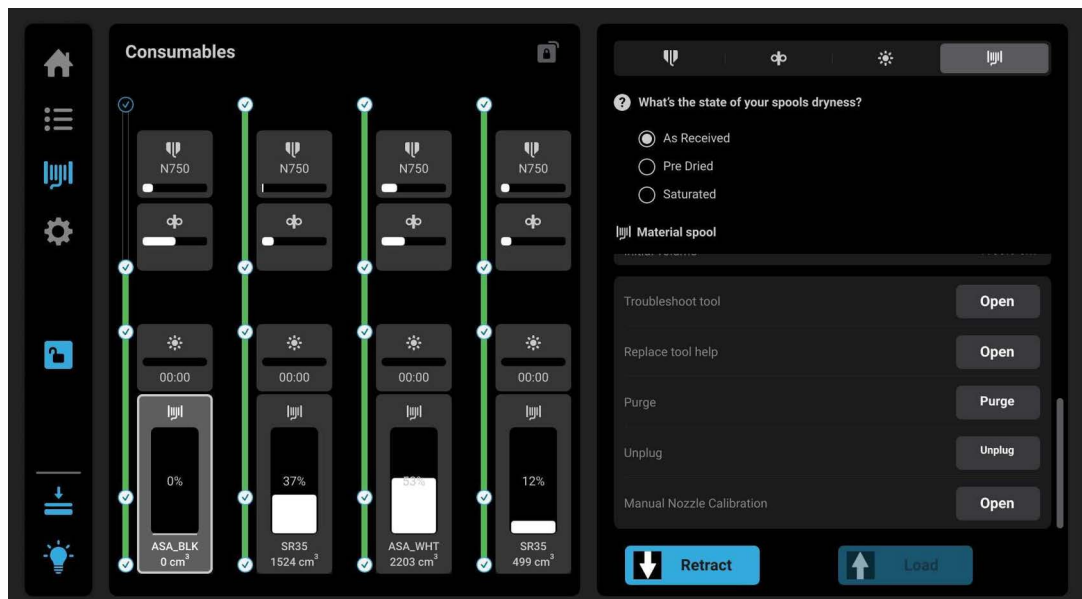
1. Insert a spool into the material bay. See [“Inserting a Spool into a Material Bay” \(page 153\)](#).
2. From the touchscreen display, select the spool in the right panel to view the material dryness options:
 - If the spool is newly opened, select **As received** from the options available.
 - If the spool is used and has been left out, select **Saturated** to ensure that the spool is dry for use after the drying cycle.
3. Feed the filament into the material guide tube until the bay drive engages and pulls the filament into the printer.



The load process is independent for each tool. All four tools can be loaded simultaneously.

4. The load process takes approximately six minutes to complete. The consumables screen provides feedback on the load process. Press the Material touchbutton for the tool being loaded. Status updates display on the right-hand pane.

Figure 171: Filament position update



5. Once filament is inserted, and the loading process has begun, the filament position status will change to the following: At Bay ([Figure 172](#)), Initializing ([Figure 173](#)), Loading to Extruder ([Figure 174](#) and [Figure 175](#)), At Head ([Figure 176](#)), and Loaded ([Figure 177](#)).

- Click the Hot End touchbutton to display extruder status during the load. See the referenced screen captures for the displayed status changes.

Figure 172: At Bay

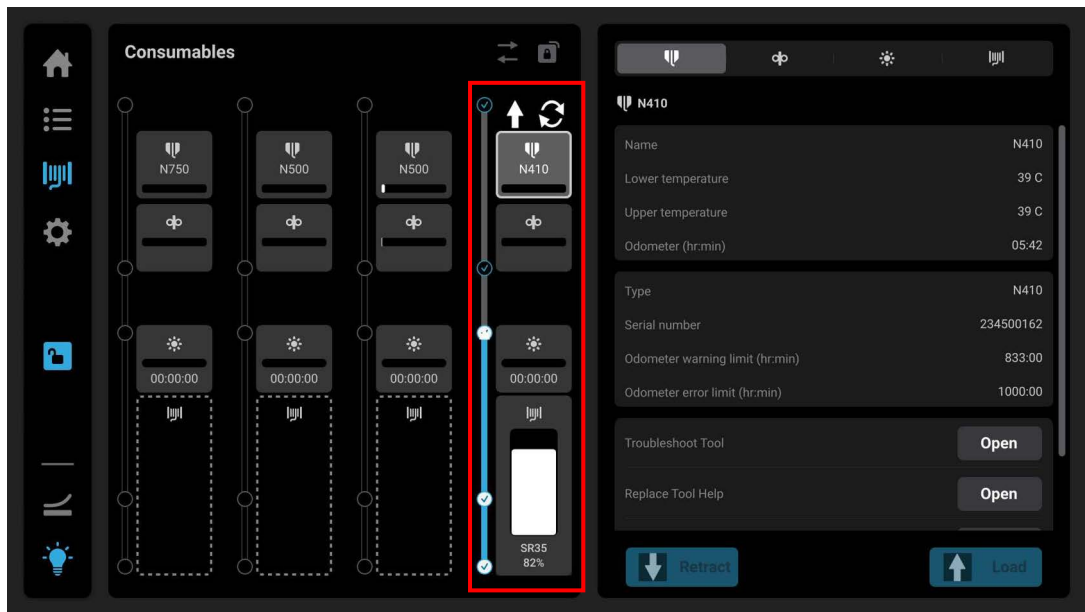


Figure 173: Initializing

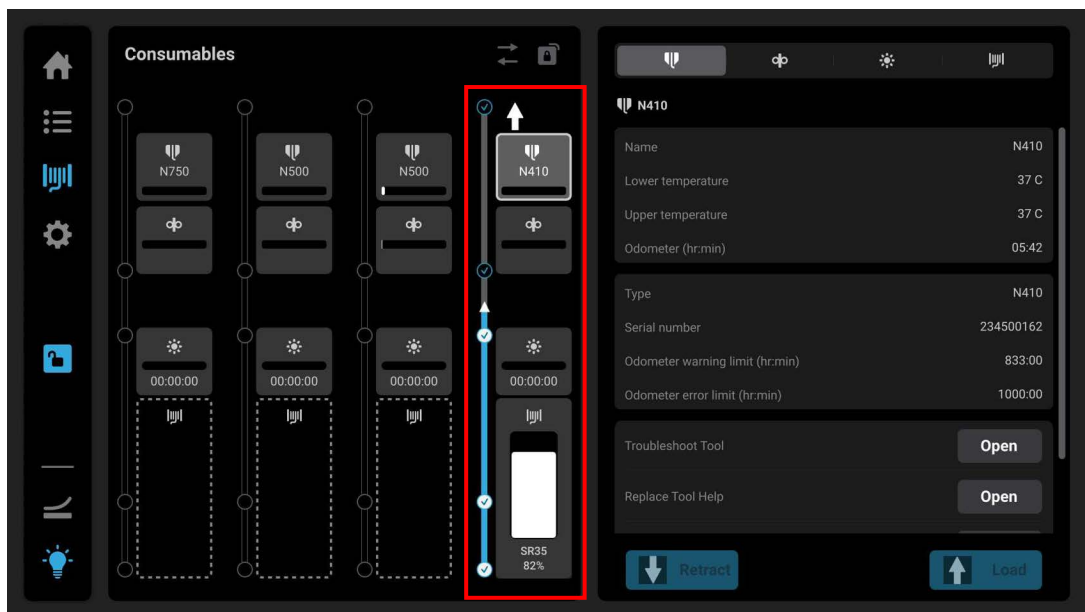


Figure 174: Loading to Extruder

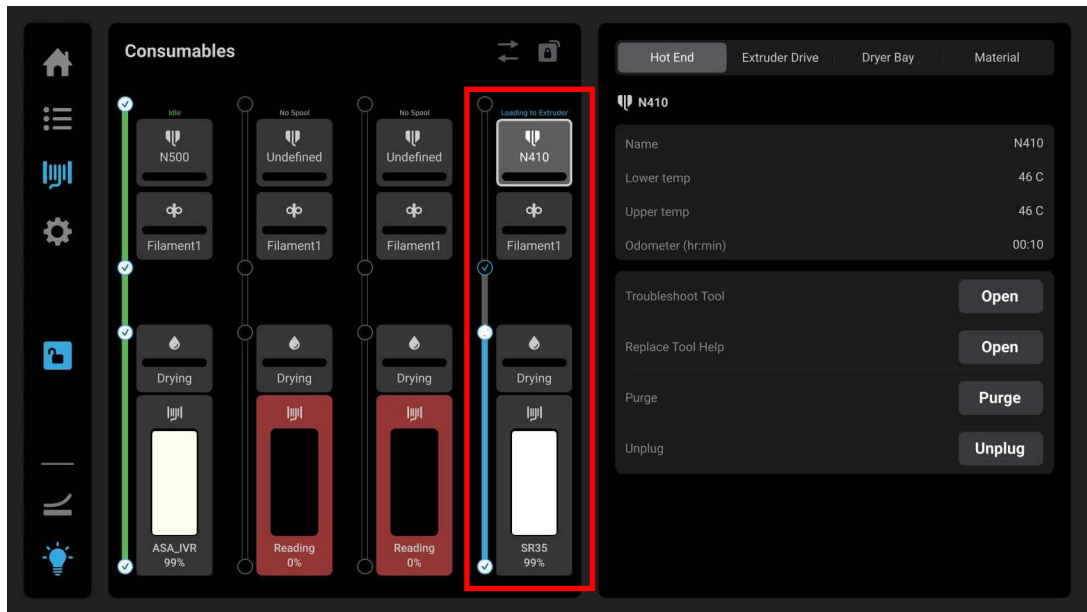


Figure 175: Loading to Extruder (continued)

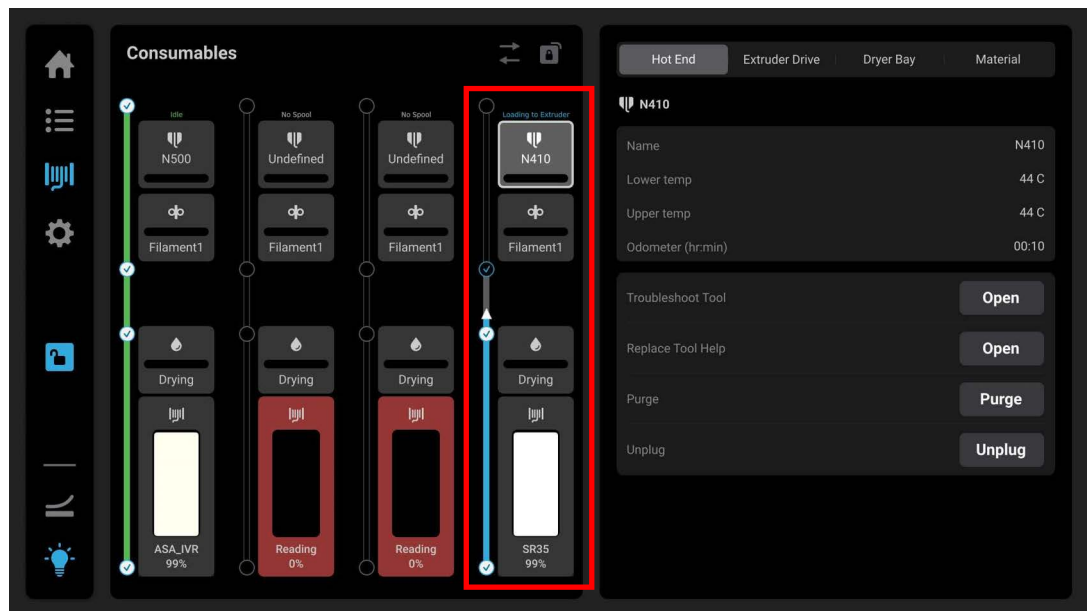


Figure 176: At Tool

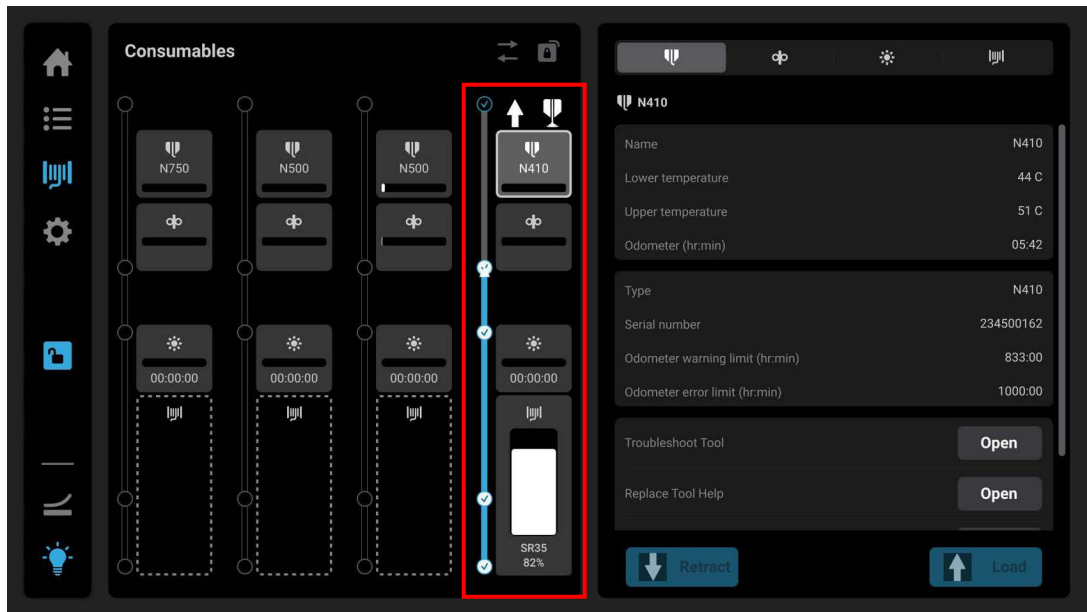
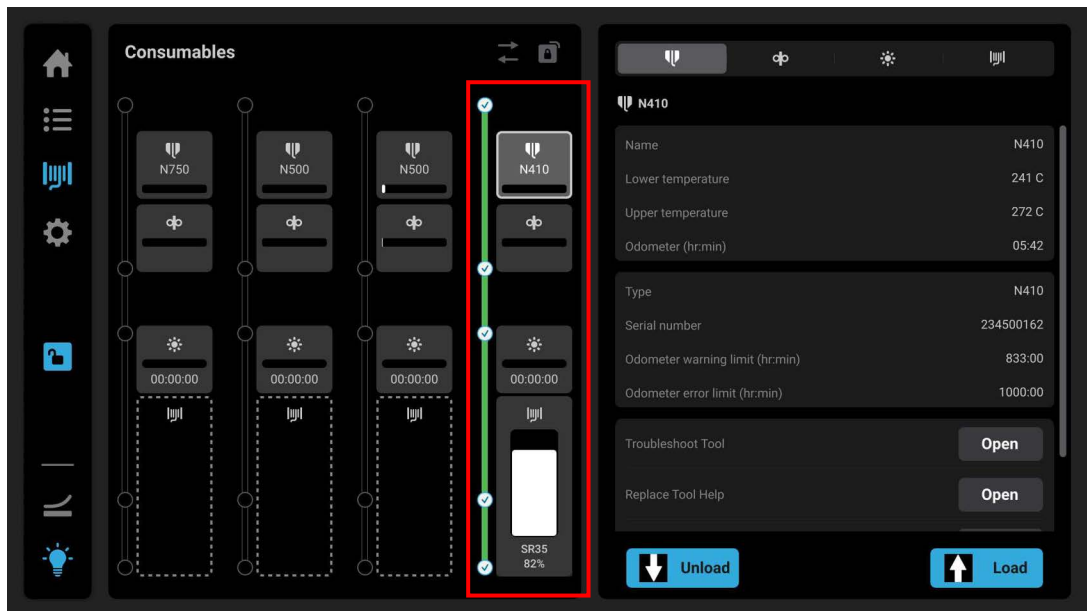
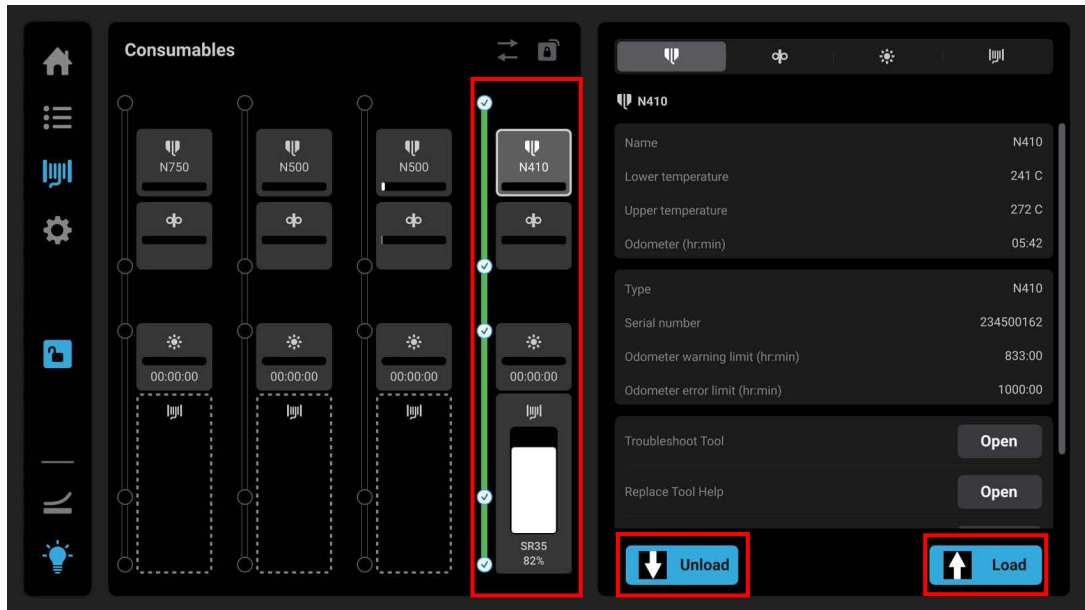


Figure 177: Loaded



- When load is totally complete, the **Load** and **Unload** touchbuttons display on the bottom of the right panel.

Figure 178: Load complete



i The extruder drive assembly displays different colors depending on the current tool status. See [“Tool Light Display States”](#) (page 117).

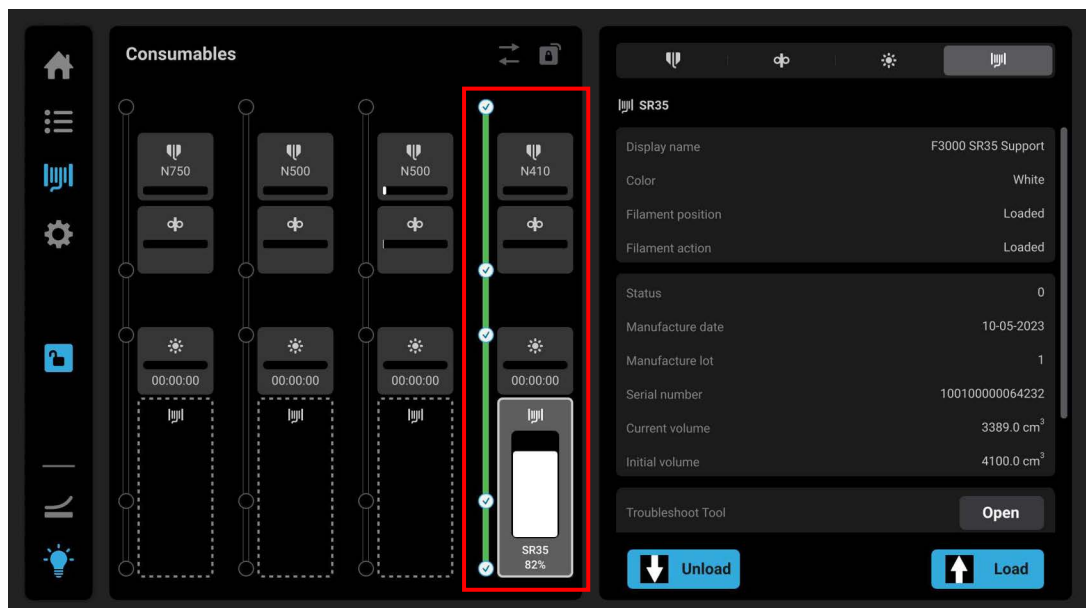
Unloading Material

Unload Material from the Tool

Perform the following steps to unload material from the tool:

1. Navigate to the Consumables screen.

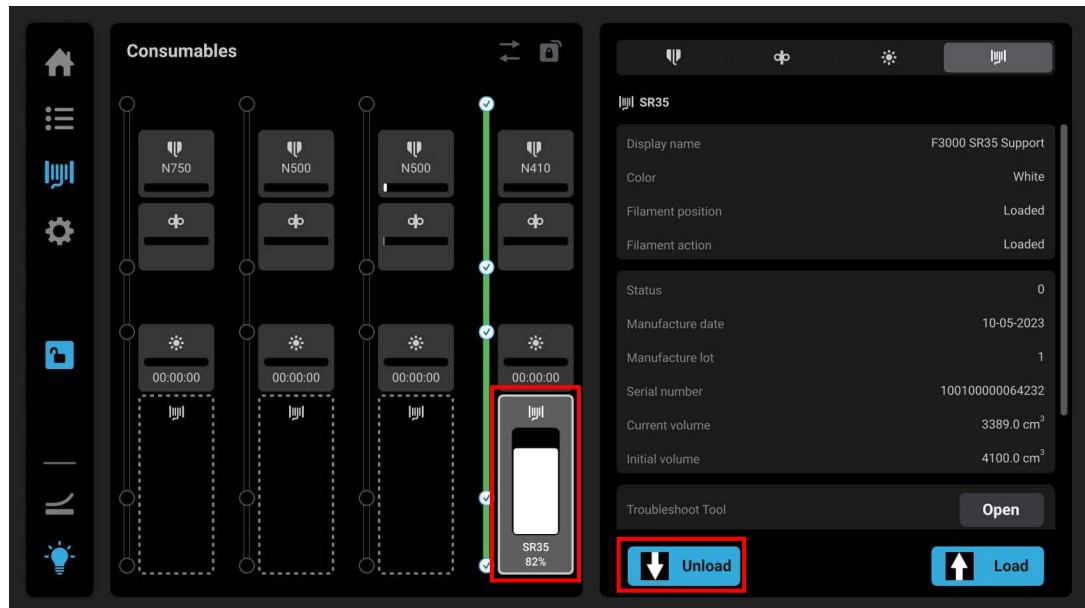
Figure 179: Consumables screen



2. Select the material bay that will be unloaded.

3. Press the **Unload** touch button.

Figure 180: Select material bay and press Unload



4. It takes approximately one minute for the material to unload from the tool. During this time, the extruder heats, and then both the extruder and bay drive backwards for a few seconds.

The filament is pulled from the hot end and left just above the extruder drive. At this point, the tool can be removed.

Figure 181: Unloading (screen 1)

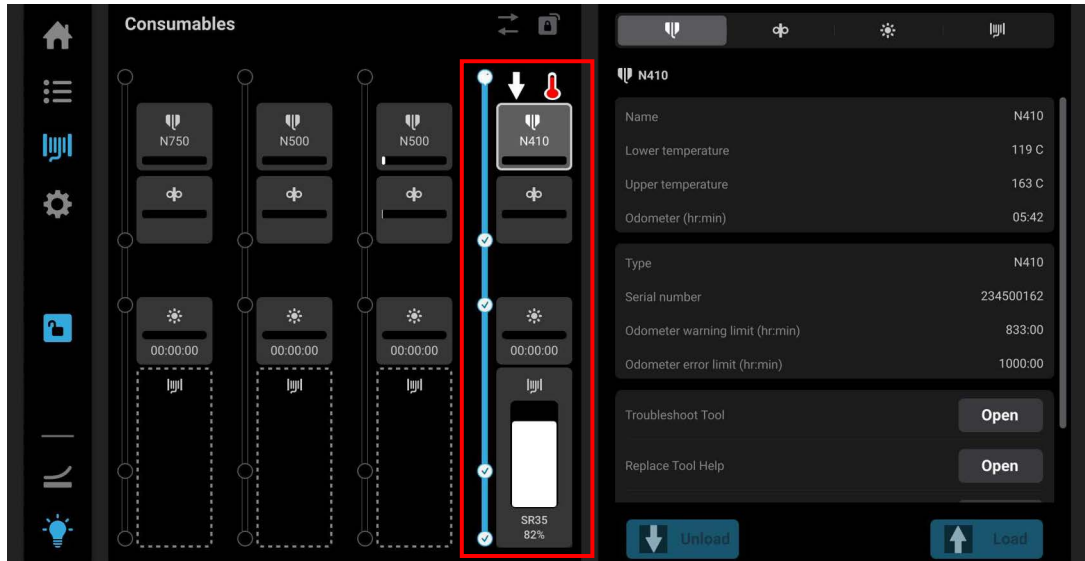
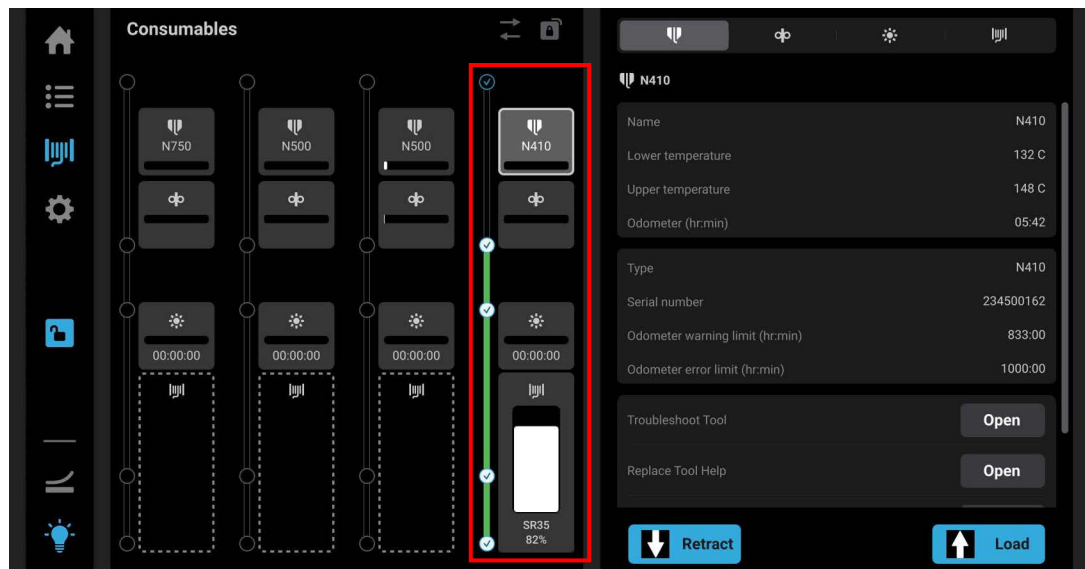


Figure 182: Unloading (screen 2)



5. The tool can now be removed to either replace the Hot End or perform troubleshooting on the tool.
6. To remove the spool, the filament must be retracted from the system. See [“Retracting Material from the System and Removing a Spool”](#) (page 166).
7. If replacing the Hot End or troubleshooting tool, the tool can be loaded by selecting **Load**. if replacing spools see [“Retracting Material from the System and Removing a Spool”](#) (page 166).

Retracting Material from the System and Removing a Spool

1. Unload material from the tool. See [“Unload Material from the Tool” \(page 163\)](#).
2. Open the material bay door for the bay to be unloaded.
3. At the filament guide, cut the filament at a perpendicular angle.
4. At the spool end, secure the filament to prevent tangling.
5. Leave the material bay door open to allow the retracted filament to exit.



Caution: Damage to Fan

Confirm the filament does not feed back into the rear of the dryer bay. If this occurs, the filament may enter the fan enclosure and cause damage to the fan.

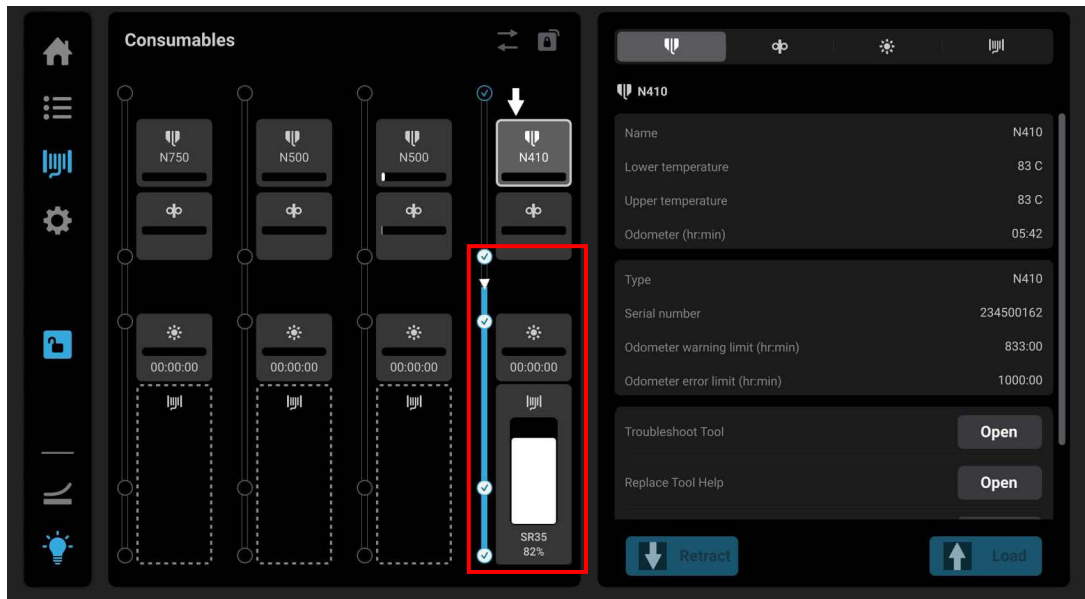
6. At the Consumables screen, press the Retract touch button. See [Figure 183 \(page 166\)](#).

Figure 183: Retract material



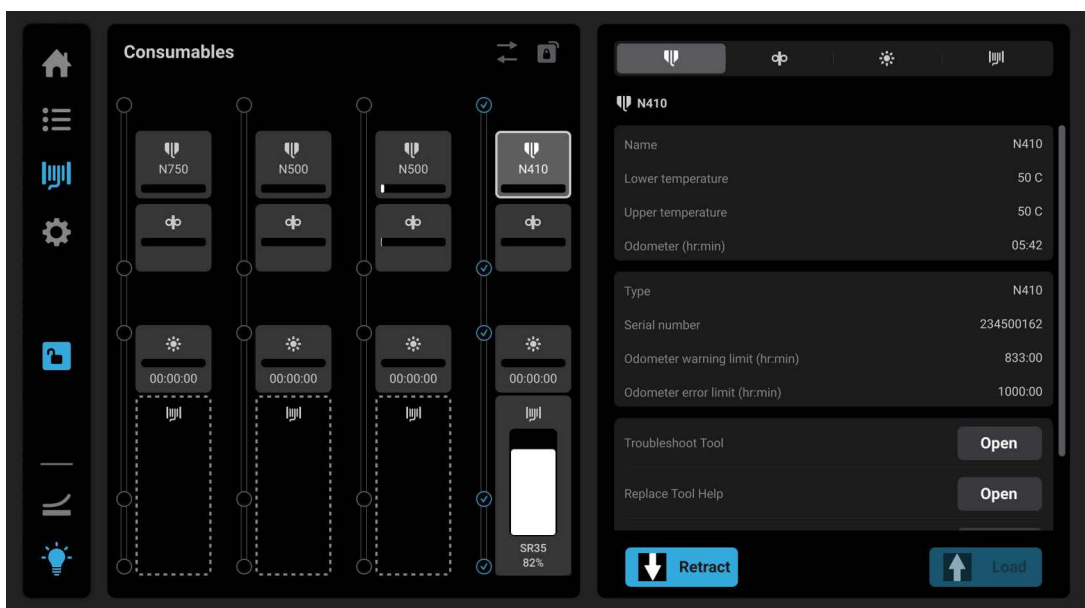
7. Select the hot end to see the unload temperature.
8. The filament position display changes from green to blue during the unload process.

Figure 184: Filament retract in process



9. The retract process takes a couple minutes. During this time, the material bay will drive backwards until filament is ejected from the material drive.
10. Remove and discard retracted filament.
11. Remove the spool and handle from system if desired.
12. Close the material bay door.

Figure 185: Material fully retracted



Handling/Storing Materials

Stratasys FDM thermoplastic materials will maintain proper product performance over an extended period of time, when handled and stored according to recommended procedures. Like other thermoplastics, the filament can absorb moisture when exposed to ambient humidity. When a filament absorbs moisture, a finished part's surface quality, seam quality, and overall part aesthetics can be affected. In addition to part quality issues, printing with wet material can cause reliability issues such as extruder jams and plugging of hot ends. While the dryer bays are capable of drying material to prevent part quality issues, additional time (up to 10 hours) is required to dry saturated material before printing. Therefore, care should be taken to ensure filament remains dry.



Box dimensions for material storage estimates are:
~ 453.25 mm x 453.25 mm x 220.5 mm (18.5 x 18.5 x 9.0 inches).



Caution: Material Storage Requirements

New unopened material storage shall be in the range of 55°F to 86°F (13°C to 30°C), with relative humidity less than 70%. Previously opened partial spools stored in sealed storage containers require the same storage conditions to ensure they remain dry when not in use.

Use the following recommended methods for storing previously opened material.

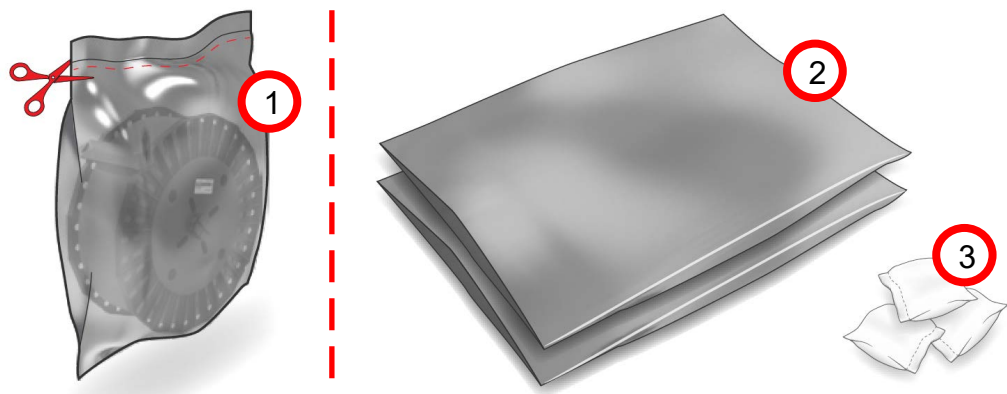
Reuse Spool Packaging

By carefully unpacking your F3300 material spools, you can save all of your package components and reuse them to help minimize filament moisture absorption when the spool is not in an F3300 dryer bay or other active heated drying cabinet. This can significantly reduce drying wait-time inside in a spare F3300 dryer bay prior to 3D printing and help maximize printer use efficiency.



Always maintain filament spool upright when handling or storing.

Figure 186: Unpacking the Material Spool



1. Carefully cut the top edge of the mylar bag just below the heat seal.
2. Flatten and store the mylar bag.
3. Save the desiccant bags and keep them inside an airtight container

Figure 187: Resealing the Spool Bag Option 1: Roll and Clip the Bag Opening



1. Place the used spool into the mylar bag, along with at least six desiccant bags.
2. Pinch and tightly roll the top bag edge. Clip with four to six large office binder type clips. Apply an extra label to identify material.
3. **Optional:** Save the original box and take advantage of its label to identify material.

Figure 188: Resealing the Spool Bag Option 2: Using a Heated Bag Sealer



1. Obtain an OEM heated mini bag sealer.
2. Use the bag sealer heating element to slide across the opening to activate the internal adhesive of the bag.

i **Tip:** Pause sealing near the end of the bag opening and compress the bag around the spool to remove excess moist air. Re-activate the remaining bag adhesive with the bag sealer.

OEM Dry Box Containers

An OEM dry box container can be utilized to store one or multiple used material spools. The minimum internal dimensions required for one filament spool is 40.13cm x 17.78cm x 40.13cm (15.8in x 7.0in x 15.8in).



Always maintain filament spool upright when handling or storing.

Figure 189: Storing Material Spools in a Dry Box Container



1. Place the partially used spool in the container along with six desiccant bags (saved from the original packaging). Affix an extra filament label to the exterior of the box or use a card/label holder. Ensure that the lid is fully fastened to prevent moisture ingress.
2. **Optional:** For additional dryness protection, reuse the mylar bag as described in [“Reuse Spool Packaging”](#) (page 169) and insert it into the dry box container.

OEM Dry Cabinets

An OEM dry cabinet is designed to store multiple used material spools. It is sealed from moisture and may contain separate heated compartments to ensure optimum temperature for drying different material types. See the OEM dry cabinet examples shown below:

Figure 190: PAC dessicator cabinet in use at Stratasys



Figure 191: StatPro PAC dessicator cabinets



Figure 192: Totech SD dryer cabinets



Exchanging the Hot End Assembly

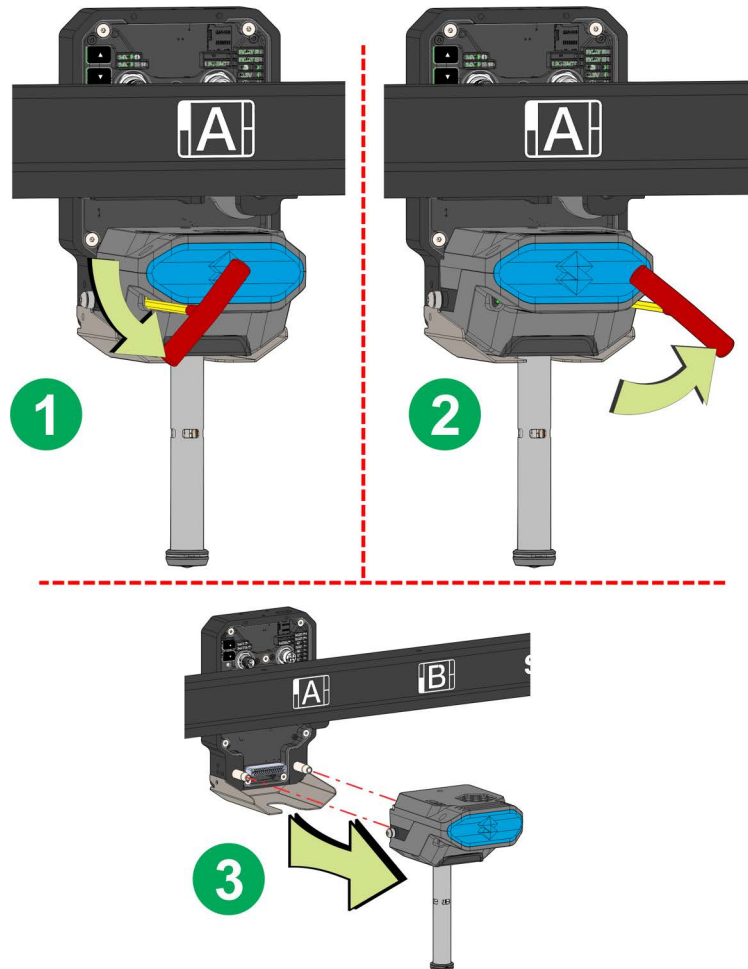
1. Unload filament from the desired extruder assembly.
2. Open the printer's front gantry hood.
3. Use a T-handle 4 mm hex wrench to disengage the screws (2) securing the existing extruder assembly to the printer tool base. Gently remove the extruder assembly by pulling the extruder drive straight out from the tool base.



Warning: Hot Surface Hazard

Do not touch the hot end of the extruder assembly. Always wear gloves when handling the existing extruder assembly.

Figure 193: Removing the existing extruder assembly



4. Remove the new hot end and extruder drive from their individual packaging.
5. Assemble the hot end to the extruder drive. Ensure that the connection is fully seated. See item 2 in [Figure 194](#).

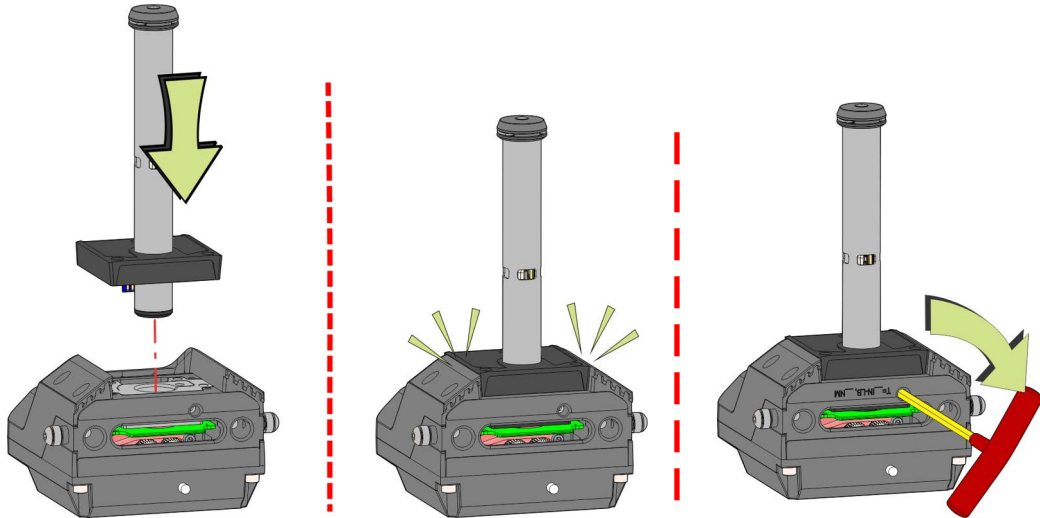
- Use a T-handle 4 mm hex wrench to snugly fasten the screw securing the hot end to the extruder drive. See item 3 in [Figure 194](#).



CAUTION: Damage to Equipment

Make sure that the hot end is properly secured to the extruder drive. If the hot end is loose, system damage or print failures will occur.

Figure 194: Constructing the extruder assembly



- Loosely install the new extruder assembly to the two alignment pins on its designated printer extruder tool base. See [Figure 195](#).
- Gently push in the extrusion tool assembly to ensure that it is fully seated in the tool base.
- Use a 4 mm hex wrench to snugly fasten the screws (2) securing the extruder assembly to the tool base.



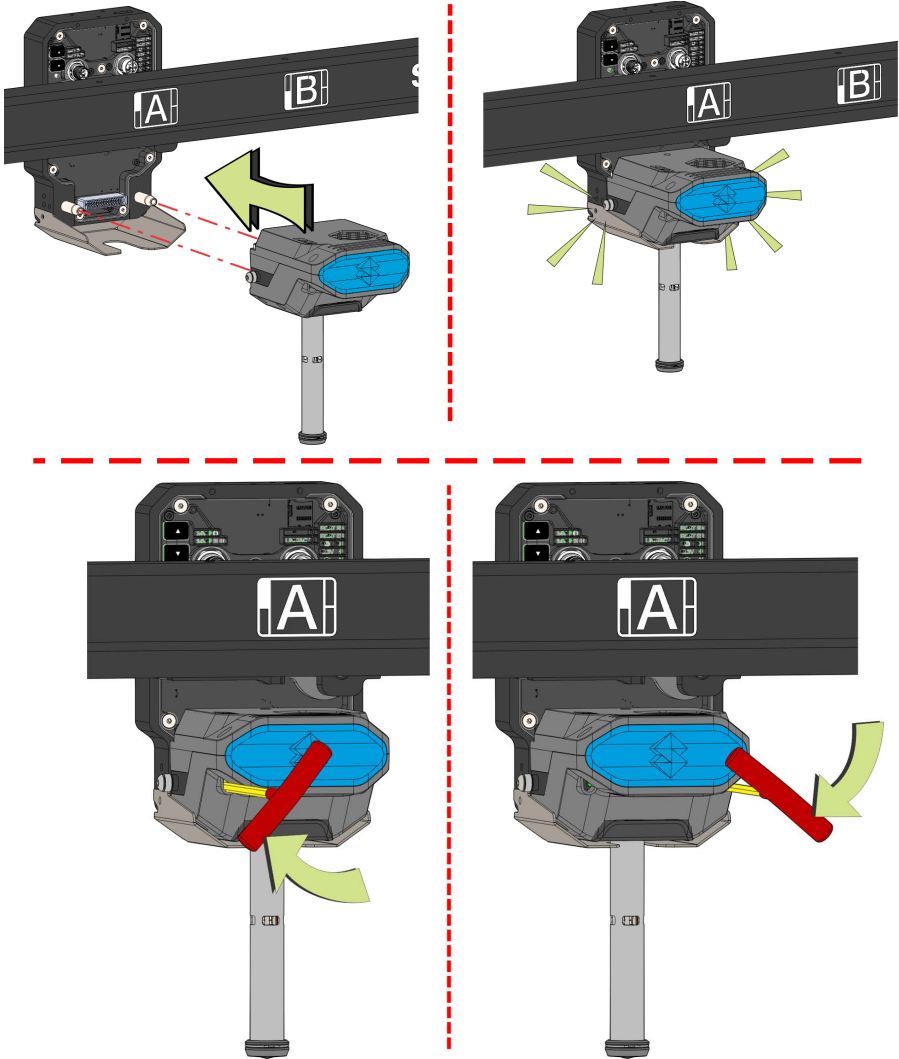
CAUTION: Damage to Equipment

Ensure the drive assembly is securely fastened otherwise system damage and part failure can result.

- Close printer hood.

11. Load the extruder assembly.

Figure 195: Installing the new extruder assembly



Basic Job Build Tasks

Before a Build

To build a job, you must first download job files to the printer and then load individual job files to the Job Queue using one of the following methods:

1. Network transfer via the GrabCAD Print application on your workstation PC. This is the preferred method for adding jobs to the Job Queue. See [“GrabCAD Print Method” \(page 124\)](#) for detailed instructions.
2. Network transfer via the Insight Control Center application on your workstation PC. See [“Insight Software” \(page 100\)](#) for detailed instructions.
3. USB method via a USB flash drive inserted into the USB port. See [“USB Method” \(page 124\)](#) for detailed instructions.

The GrabCAD Print and Insight Control Center options allow you to select a job which was processed and sent to the printer (via your facility’s Ethernet connection) using the GrabCAD Print application on your workstation PC. Jobs are sent in CMB format and placed directly into the Job Queue (stored on the printer’s hard drive). The CMB file contains the processed job’s basic information; this information is used to verify job compatibility with the printer’s existing configuration. For information on using GrabCAD Print, see the associated Help file within the GrabCAD Print application.

The USB option allows you to select a job file which is stored on a USB flash drive inserted into the USB port. This method can be used as a backup to the GrabCAD Print or Control Center methods if you are unable to transfer job files to the printer via your network connection (due to poor connectivity, a network outage, etc.). See [“Loading a File” \(page 111\)](#) for details.

Installing a Build Sheet

To install a build sheet and prepare the printer for a build:

1. Power ON the printer (see [“Powering On the Printer”](#) (page 146) for instructions).



Warning: Hot Surface Hazard

Always wear proper heat protective gloves and clothing when handling items inside the oven, as surfaces within the oven can be very hot.



Caution:

To ensure a successful build, allow the oven to reach thermal stabilization and idle temperature before turning on platen vacuum. It will take approximately one 1 hour for the printer oven to reach thermal stabilization when starting from room temperature.

2. Open the oven door and clean the platen, as needed, to remove any debris. Close the oven door.
3. Prepare the build sheet by removing the build sheet from its packaging.



Install the build sheet as quickly as possible to prevent the oven temperature from dropping below the stabilization point. This process should be completed in less than two minutes.

4. Once the oven has stabilized, open the door and install the build sheet with the smooth side down. Ensure the build sheet is centered on the platen before closing the door.
5. Allow the build sheet to thermally stabilize for 20 seconds and then turn on the platen vacuum by pressing the Vacuum Control icon on the User Interface.
6. Confirm a good vacuum seal between the platen and the build sheet.



- A properly installed build sheet does not need to be adjusted between successive builds.
- Always use a new build sheet when building a job. The build sheet is intended for one-time use.
- Do not turn a build sheet over and place it on the platen. Material residue on the sheet can adhere to the platen or interfere with the build sheet vacuum.
- Using build sheets not provided by Stratasys may impact part quality and printer reliability.

Starting a Part

You can start a part only when the light tower is green

If the light tower is not green, press the play button to get a list of what is preventing part start.

Preconditions for part start (how to get the green tower light):

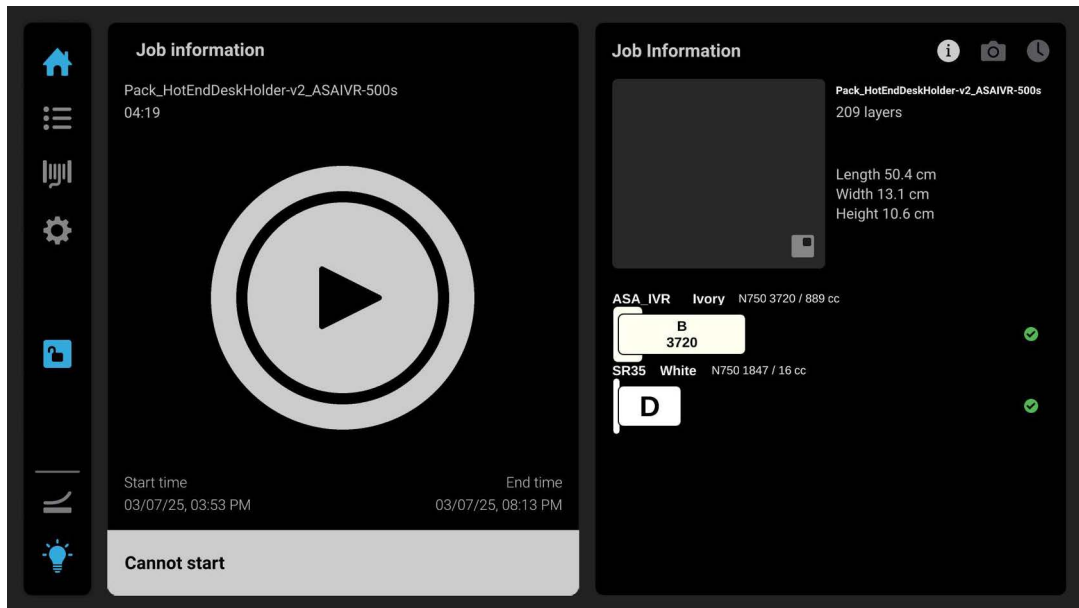
- CMB file in queue
- Vacuum sealed
- Material loaded
- Oven temperature stabilized

Figure 196: Home screen – Grey circle indicates no job in queue



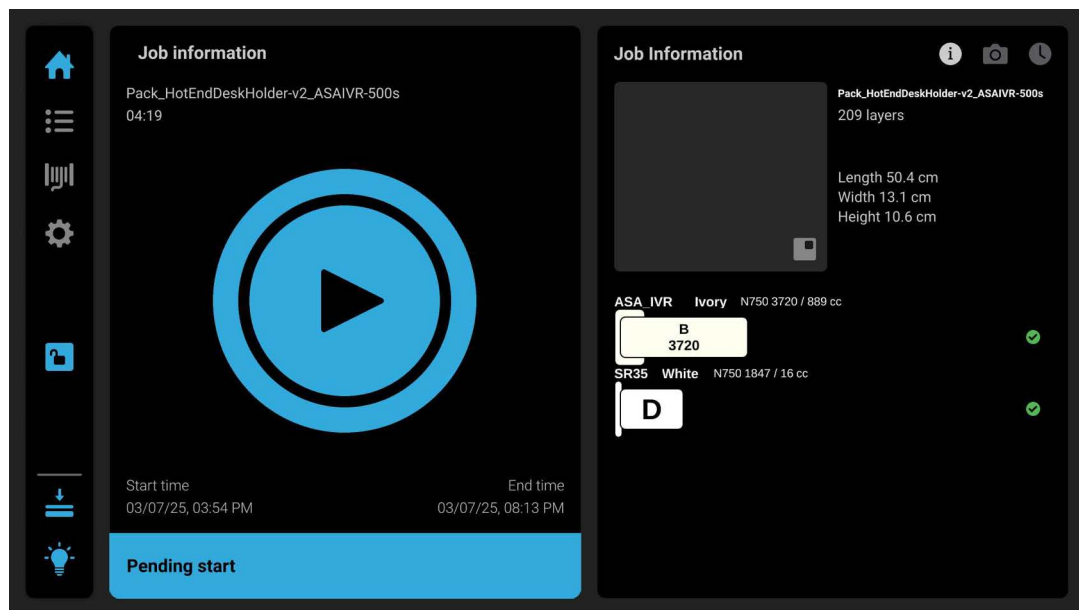
Download job files to the printer and then load individual job files to the Job Queue. See [“Adding a Job to the Job Queue” \(page 124\)](#).

Figure 197: Home screen with part in queue – play button is visible



The Build menu indicates whether appropriate tools and materials are available for the selected part. Verify the total amount of material available and state of each hot end.

Figure 198: Material is loaded



Turn the vacuum on by pressing the vacuum graphic on the left pane.

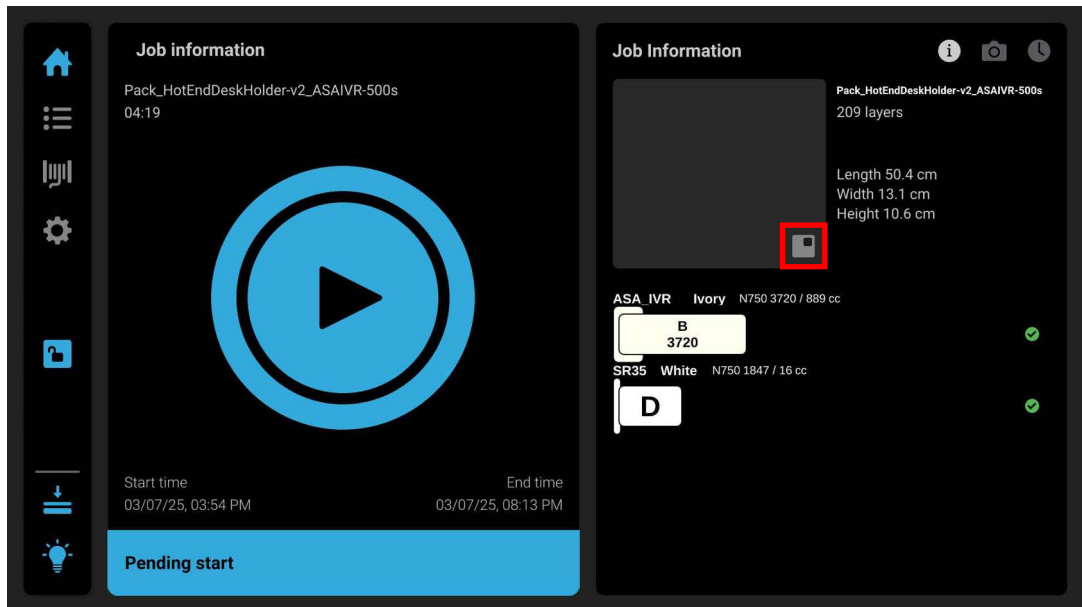
A grey icon indicates that vacuum is off. A blue icon indicates that vacuum is on. A blue icon with two flat lines indicates vacuum is achieved and building may commence.

Figure 199: Left pane



Select a location on the platen for the build to occur.

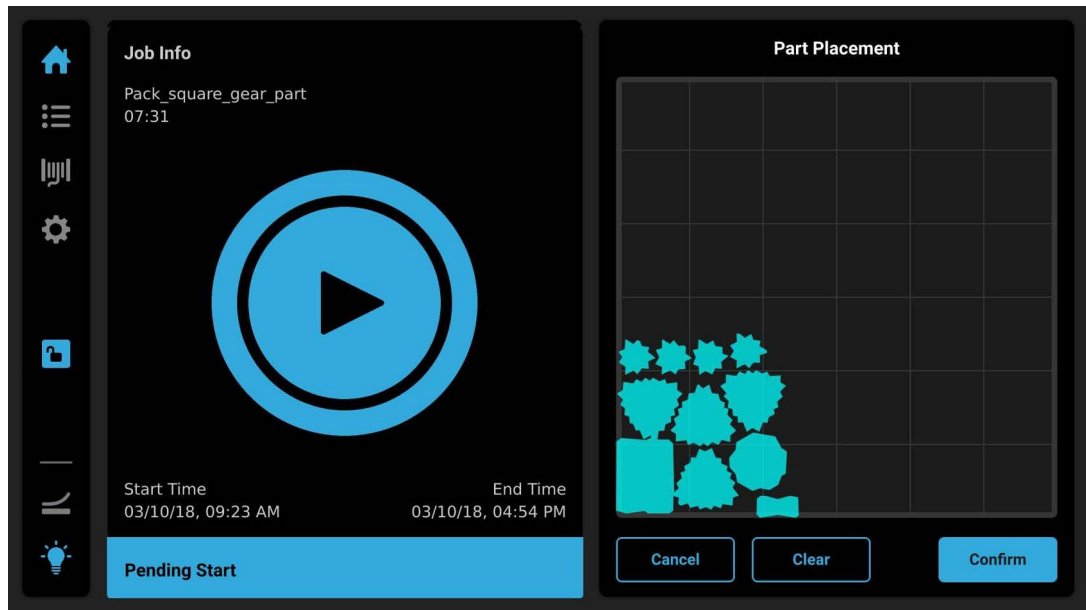
Figure 200: Select platen build location



The part placement sub menu displays on the right side of the current window. Move the part to the desired location on the platen. After confirming the location, the part can be started by pressing the play icon.

The operating system tracks platen build locations, which allows for better placement locations. This information is lost if the printer is shut down or rebooted. As such, a new build sheet is required after a restart of the printer.

Figure 201: Platen build location selected



Optimizing Tool Order and Setting Up Redundancy

Tool order can be established on the Home build page to ensure that spools are used efficiently or to set up redundancy to complete builds without pauses or needed intervention.

For efficient use of spools, a low volume spool can be setup to start the build and when it runs out of material, a tool change will occur to a second tool with the same material and hot end. After the tool change, the first tool can be prepared with a new spool and be setup as a back up for redundancy or for extended builds where multiple spools may be needed.

For critical builds, the F3300 can be configured for redundancy, and will continue to build if an error is encountered on the initial tool. Two tools will need be configured with the same material and hot end size. Each tool must have sufficient material to complete the build. If an error occurs, the printer will automatically switch to the second tool to complete the build. Attending to the error on the first tool and fixing it while the build continues will ensure that the build completes uninterrupted in case a second error occurs.

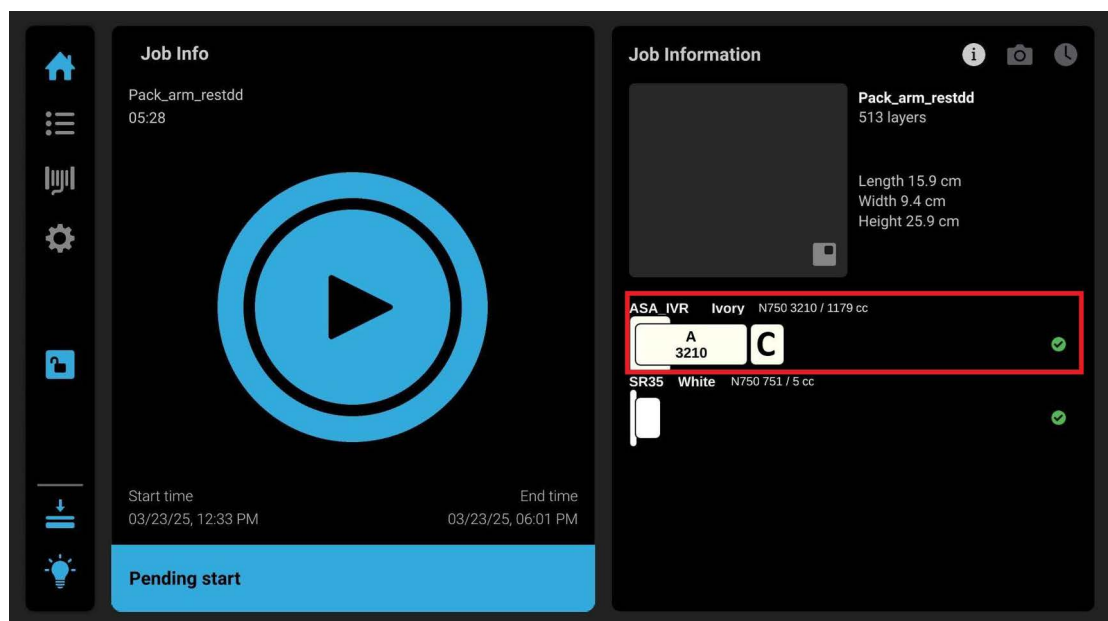
Tool Order:



- Tools near or over the specified warranty hours will display a warning and will automatically be set a lowered preference.
- Tools with spools that have the lowest amount satisfying the job requirements will be selected first.
- Jobs that require more than one spool will be selected lowest to highest alphabetically.
- Tool order can be manually changed by the user, using the options noted below.

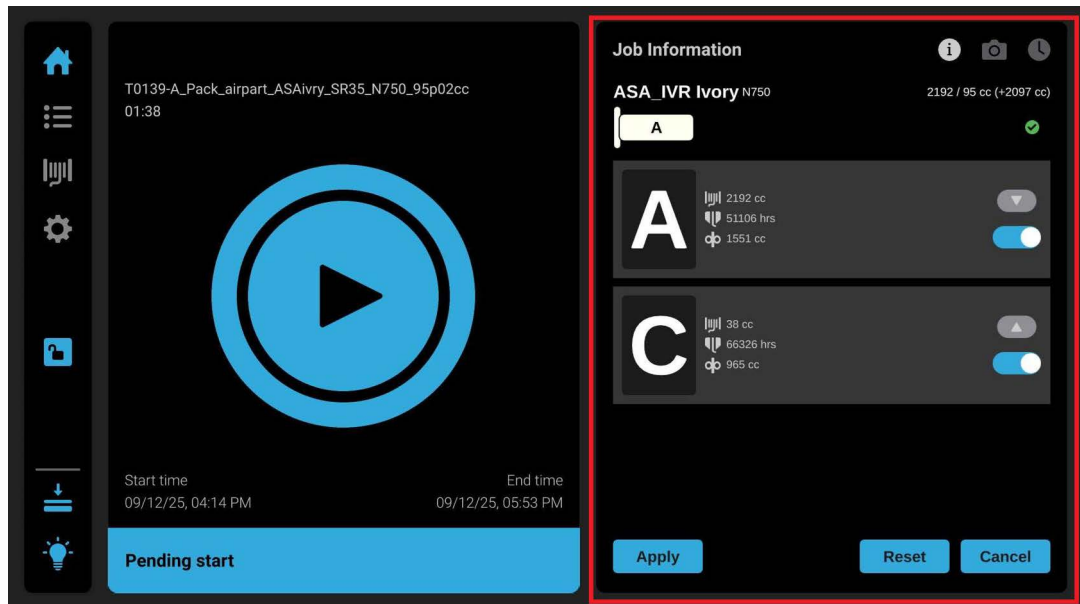
Select the tool options to display options for modifying the tool order.

Figure 202: Tool Options



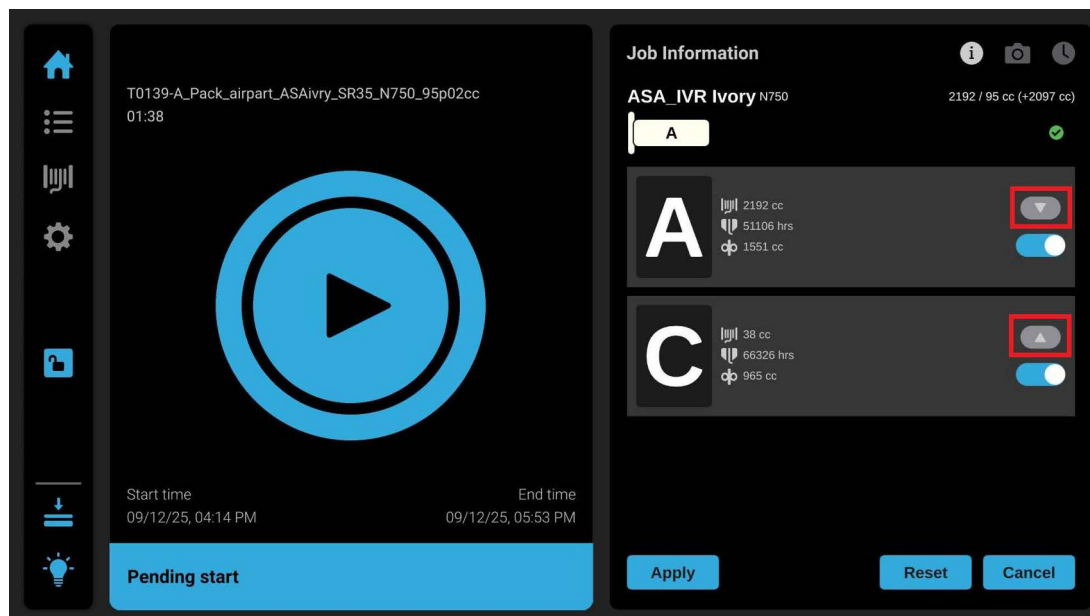
In the image below, the tool order is specifying Tool A as the initial tool. Tool C is the redundant back-up tool since each of these tools have enough material to complete the selected part.

Figure 203: Home Page, Tool Order



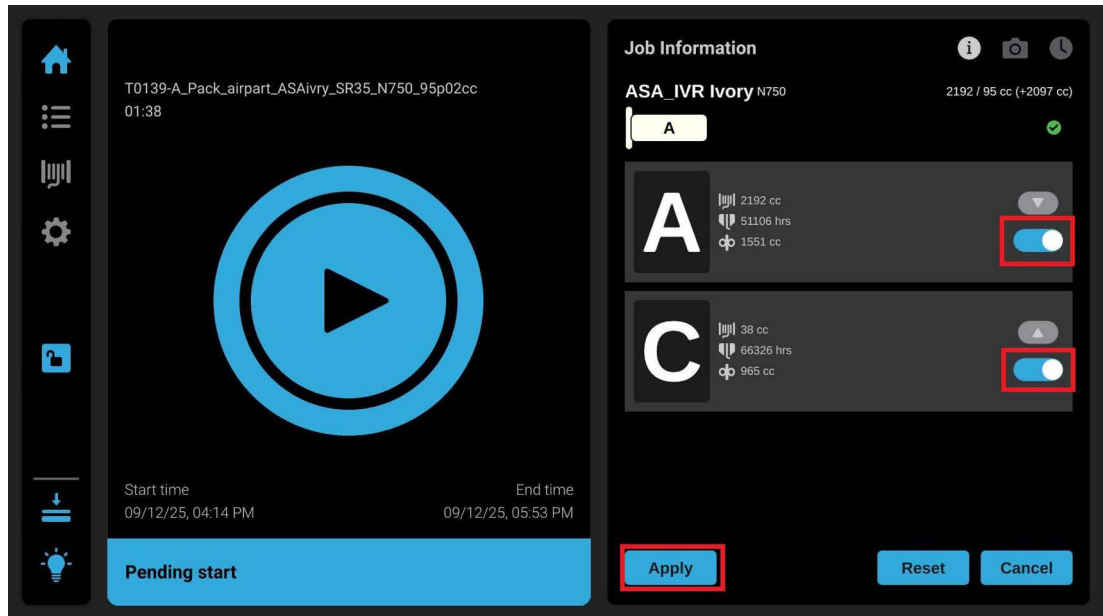
Select the arrow buttons to make changes to the current tool order.

Figure 204: Changing Tool Order



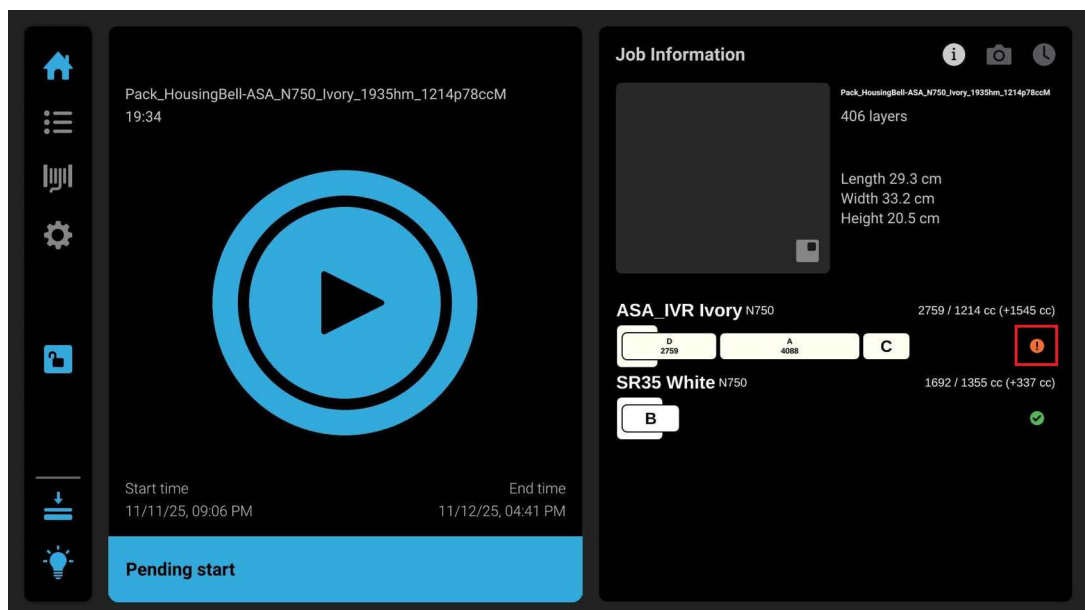
In addition, there is an option to activate a tool that is prepared after a part has already been started. In the image below, Tool A and C are active, but can be deactivated by toggling to the left, or activated by toggling right. Select **Apply** to save any changes.

Figure 205: Tool Activation Toggle Switch



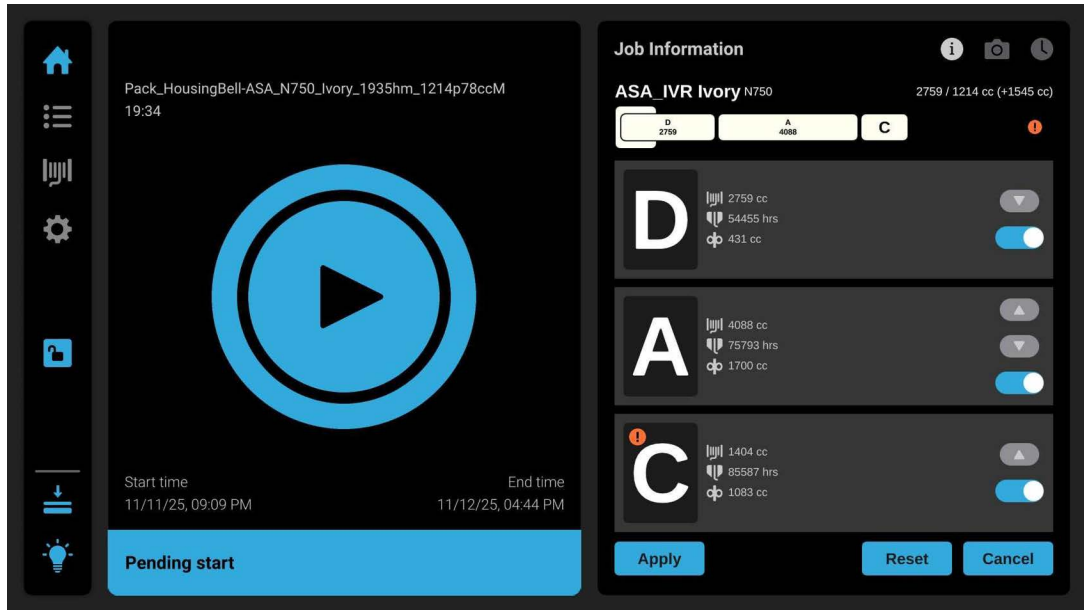
As noted above for tool order, in the image below, tool D is the primary tool with A and C as redundancy. There is a warning for tool C.

Figure 206: Tool C Warning



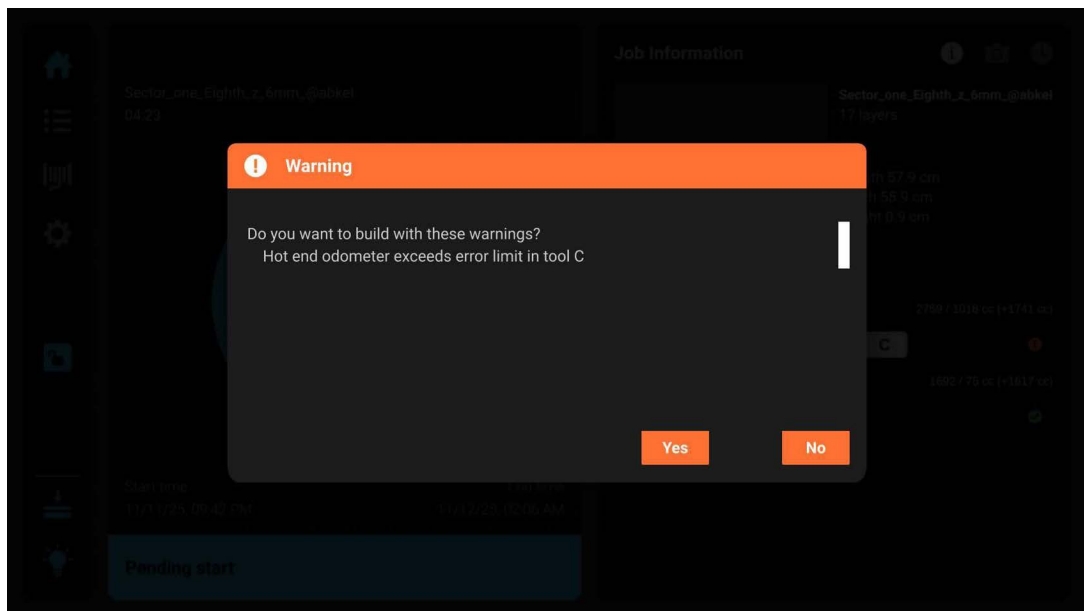
Selecting the tool option will display the options with C showing a warning and the hot end odometer at 855 hours. (warning begins at 833 hours).

Figure 207: Hot End Odometer Warning



If a part is started with the tool C enabled while showing a warning, the user will be prompted to acknowledge the warning before continuing. Selecting **Yes** to continue or **No** to abort.

Figure 208: Yes or No Response Required



After a Build is Complete

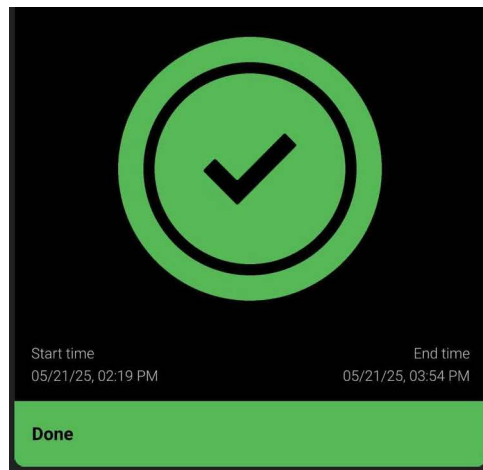
After the completion of a build, the printer performs the following actions:

- The Z stage is lowered and the head assembly is parked.
- "DONE" is displayed within the Build Status Display ([Figure 209 \(page 187\)](#)).
- The Build button will display a green checkmark icon indicating that the build completed successfully.



If the build was terminated abnormally, a warning indicator will be displayed on the screen. See ["Build Abort Errors" \(page 238\)](#) for a list of abort related warnings/errors and resolution instructions.

Figure 209: Print Successful Dialog



Removing a Part from the Printer



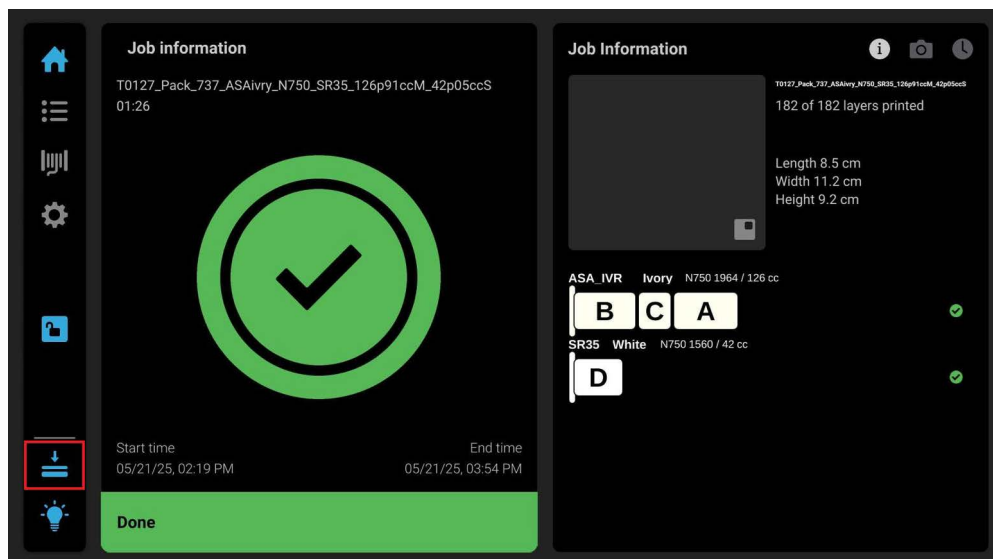
Warning: Hot Surface Hazard

Always wear proper heat protective gloves and clothing when handling items inside the oven, as surfaces within the oven can be very hot.

To remove a part from the printer:

1. Open the oven door.
2. From the touchscreen interface, select the **Platen Vacuum** button on the **Navigation** menu to release vacuum.

Figure 210: Vacuum Enable/Disable



Caution: Damage to Equipment

Use caution if removing a part from the build sheet while the build sheet is on the platen. Damage to the platen or the platen level can result.

3. Remove the build sheet from the platen.
4. Carefully remove the part from the build sheet.

Changing Material from ULTEM™ Resin to ASA



Warning: Hot Surfaces.

Always wear safety gloves and long sleeves when working inside the oven. Components are hot.



Caution: Damage to Equipment

The melting point of ULTEM resin is significantly higher than that of ASA. Failure to follow work instructions may result in damage to the machine.

1. Release platen vacuum by pressing the **Platen Vacuum** button on the **Navigation** menu to release vacuum.
2. Open the oven door and remove the build sheet as well as any printed parts.
3. Unload ULTEM resin material. See [“Unloading Material” \(page 163\)](#).
4. Remove the ULTEM resin material and the spool. See [“Retracting Material from the System and Removing a Spool” \(page 166\)](#).
5. To clean miscellaneous material from the oven using a vacuum cleaner, access the **Settings** page from the **Navigation** menu.
6. Press **Move Stage** at the bottom of the page, and raise the platen in Z until adequate clearance is created.
7. Vacuum all extruded material from the oven.
8. Change the hot end. See [“Exchanging the Hot End Assembly” \(page 174\)](#).
9. Load ASA material See [“Loading Material” \(page 153\)](#)
10. Load ASA material to the tool. See [“Loading Material into the Tool” \(page 158\)](#)



Caution: Damage to Equipment

Waiting for the oven temperature to stabilize is critical. Failure to allow oven stabilization time could result in severe damage to the platen.

11. Install a new build sheet. See [“Installing a Build Sheet” \(page 178\)](#).
12. When the **Play** button is displayed on the GUI, the printer is ready for a new build.
13. The auto tip calibration process now begins and will then proceed to build the selected job.

Changing from ASA to High Temperature Materials



Warning: Hot Surfaces.

Always wear safety gloves and long sleeves when working inside the oven. Components are hot.



Caution: Damage to Equipment

The melting point of ULTEM resin is significantly higher than that of ASA. Failure to follow work instructions may result in damage to the machine.

1. Release platen vacuum by pressing the **Platen Vacuum** button on the **Navigation** menu to release vacuum.
2. Open the oven door and remove the build sheet as well as any printed parts.
3. Unload ASA or other low temperature material. See [“Retracting Material from the System and Removing a Spool” \(page 166\)](#).
4. To clean miscellaneous material from the oven using a vacuum cleaner, access the **Settings** page from the **Navigation** menu.
5. Press **Move Stage** at the bottom of the page, and raise the platen in Z until adequate clearance is created.
6. Vacuum all extruded material from the oven.
7. Change the hot end. See [“Exchanging the Hot End Assembly” \(page 174\)](#).
8. Load ULTEM filament or other high temperature material. See [“Loading Material” \(page 153\)](#).
9. Load ULTEM filament or other high temperature material to the tool. See [“Loading Material into the Tool” \(page 158\)](#).
10. The auto tip calibration process now begins. Wait until the end of this process and until the oven temperature stabilizes.



Caution: Damage to Equipment

Waiting for the oven temperature to stabilize is critical. Failure to allow oven stabilization time could result in severe damage to the platen.

11. Install a new build sheet. See [“Installing a Build Sheet” \(page 178\)](#).
12. When the **Play** button is displayed on the GUI, the printer is ready for a new build.

Changing Printer Defaults

Several factory presets can be changed via the options within the Settings menu.

Software Version

The following steps explain how to determine the software version installed on the printer.

If currently working at the printer, use the touchscreen to select the Settings menu, and scroll down and select Version Numbers. The current software version is displayed here.


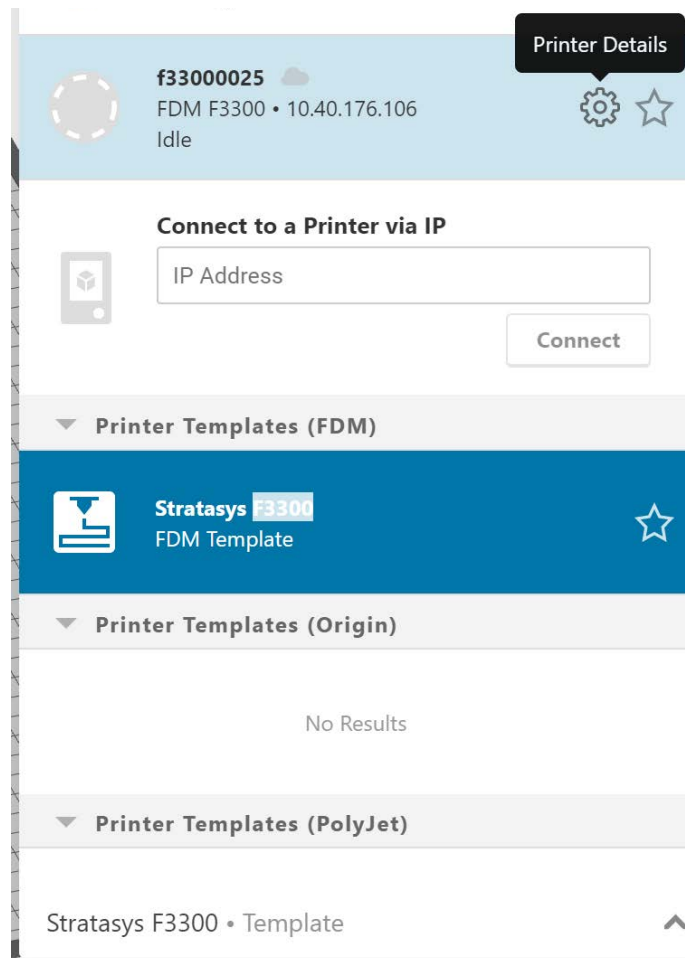
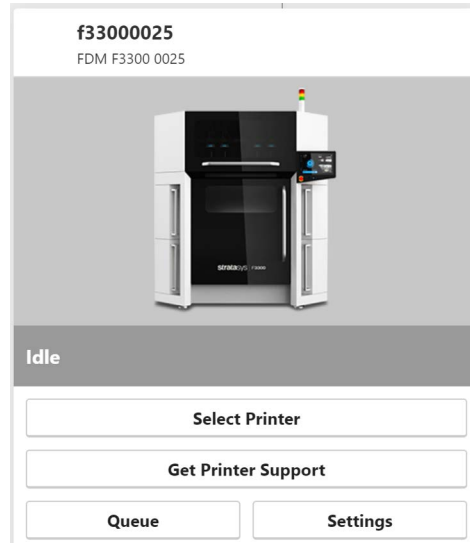
1. If currently using GrabCAD Print, open the **Printer** panel and either search for or scroll to the desired printer.
2. Click on the  icon to view the printer details.

Figure 211: Printer Details



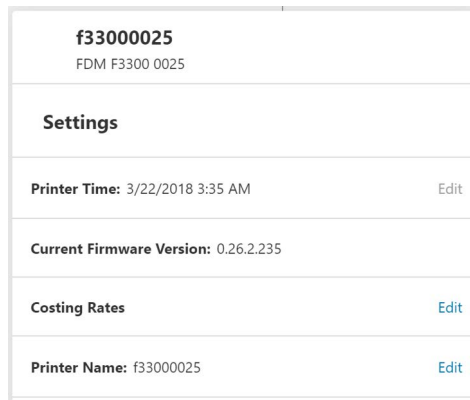
- From the **Details** panel, click **Settings**.

Figure 212: Settings



- The current firmware version is displayed on the settings panel.

Figure 213: Firmware version

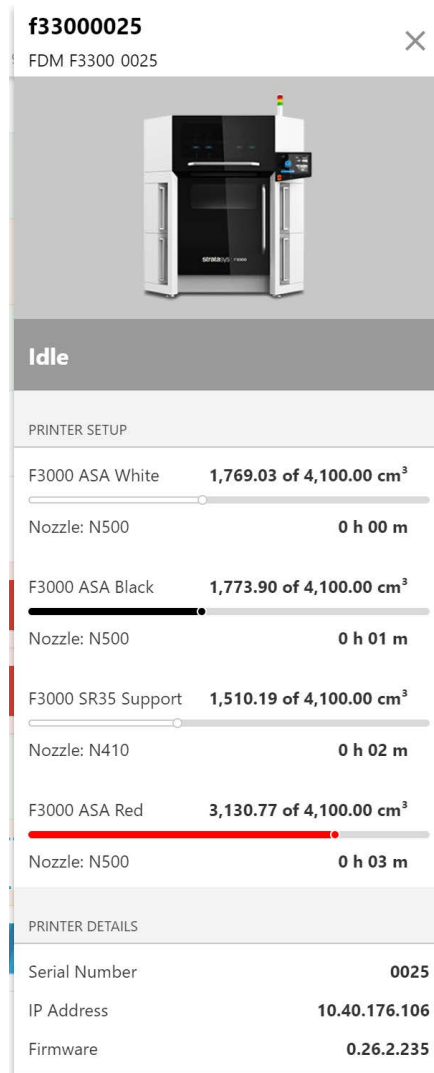


In GrabCAD Print, the firmware version can also be accessed using the schedule view.

- Click the **Schedule** icon in the left-hand toolbar.
- Scroll to the printer for which you want to know the firmware version.
- Click on the **Row** header for that printer.

- The **Details** panel displays on the right-hand side of the application. The firmware version is in the **Printer Details** section at the bottom of the panel.

Figure 214: Firmware version using schedule view

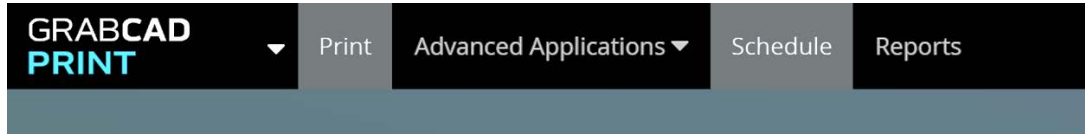


The following two procedures use the GrabCAD Print Server to find the printer firmware version for remote printers. The first accesses grabcad.com using a browser.

- Using a web browser navigate, to grabcad.com and sign in.
- Choose the account that includes the F3300 printer.

3. Select **Schedule**.

Figure 215: Schedule

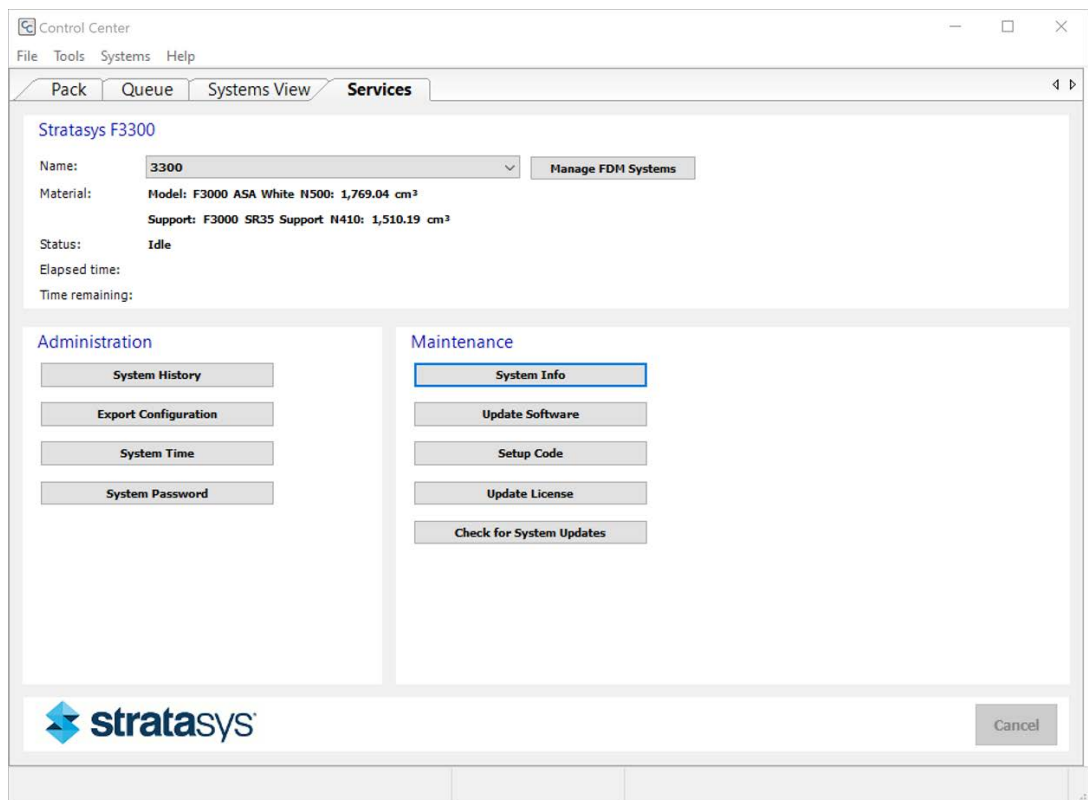


4. Scroll to find the F3300 printer and click the row header.
5. **Printer Details** displays on the right-hand side of the browser window. The firmware version is found in the **Printer Details** section of the panel.

To find the system software version using Control Center:

1. Select the **Services** tab and click the **System Info** button.

Figure 216: System Info button



- The System Information dialog displays. The system software version and other system information can be found here, along with an internal camera view.

Figure 217: System Information Dialog Box



7 Maintaining the Printer

This chapter describes various maintenance tasks that will routinely need to be performed on the printer.

Calibration and Adjustments

This section describes basic calibration and adjustment procedures for the printer.

Automatic Tip Calibration

Tip offset values are the distance between all of the hot ends that will be in use for a job in the X, Y and Z directions. Accurate tip offset values ensure that support toolpaths are accurately located in reference to model toolpaths. Inaccurate tip offset values can cause part quality issues, such as support material embedded in a part or improperly supported parts.

Automatic Tip Calibration registers the tips in relation to the different hot ends in use, including other colors and support. This calibration is automatically performed and ensures that positioning of the head and Z axis is correct when changing between model and support material during a build.

Place a new build sheet onto the platen and turn the vacuum control system On to firmly attach the build sheet to the platen. Ensure build sheet is installed with the smooth side down.

Tip Wipe Height Adjustment

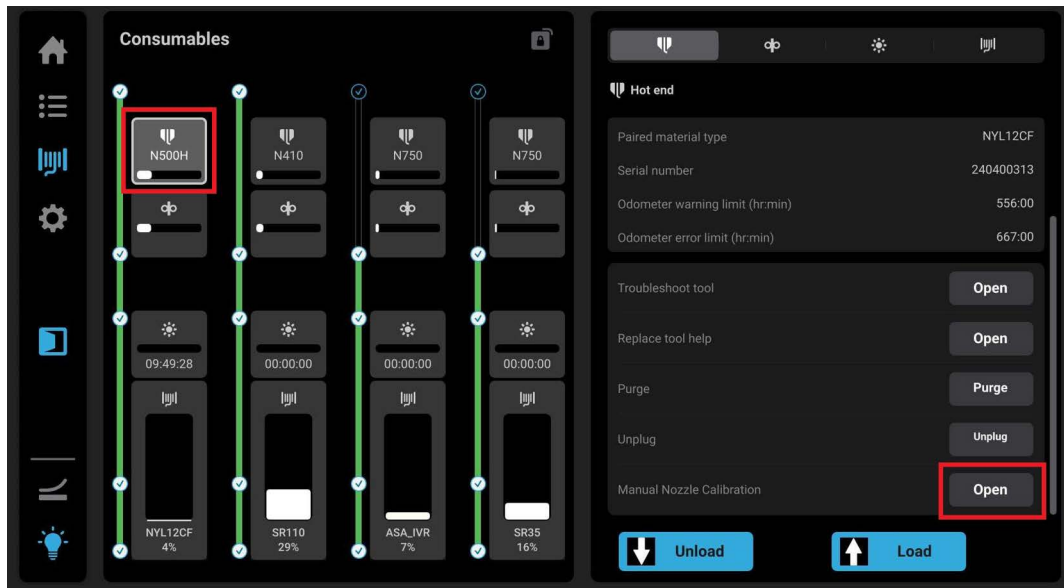
The tip wipe height adjustment is set at the factory. If further adjustment is needed, contact Stratasys Customer Support or your regional Stratasys office (see [“Getting Help” \(page 236\)](#) for contact information).

Manual Nozzle Calibration

Procedure

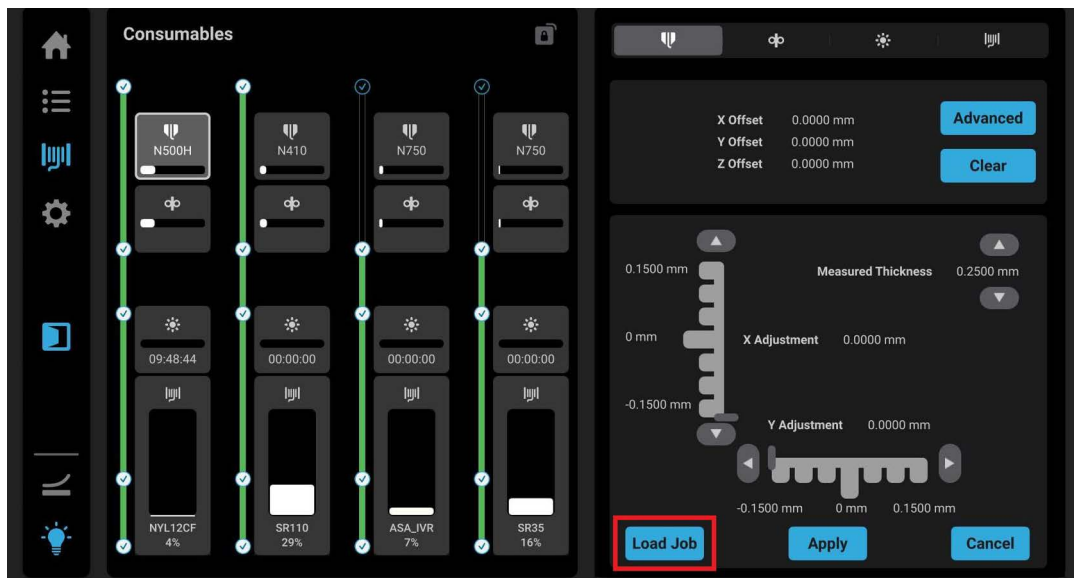
1. From the Consumables menu, select the tool to be calibrated. Scroll down on the right side of the pane to reveal Manual Nozzle Calibration and select **Open**.

Figure 218: Consumables Menu, Manual Nozzle Calibration



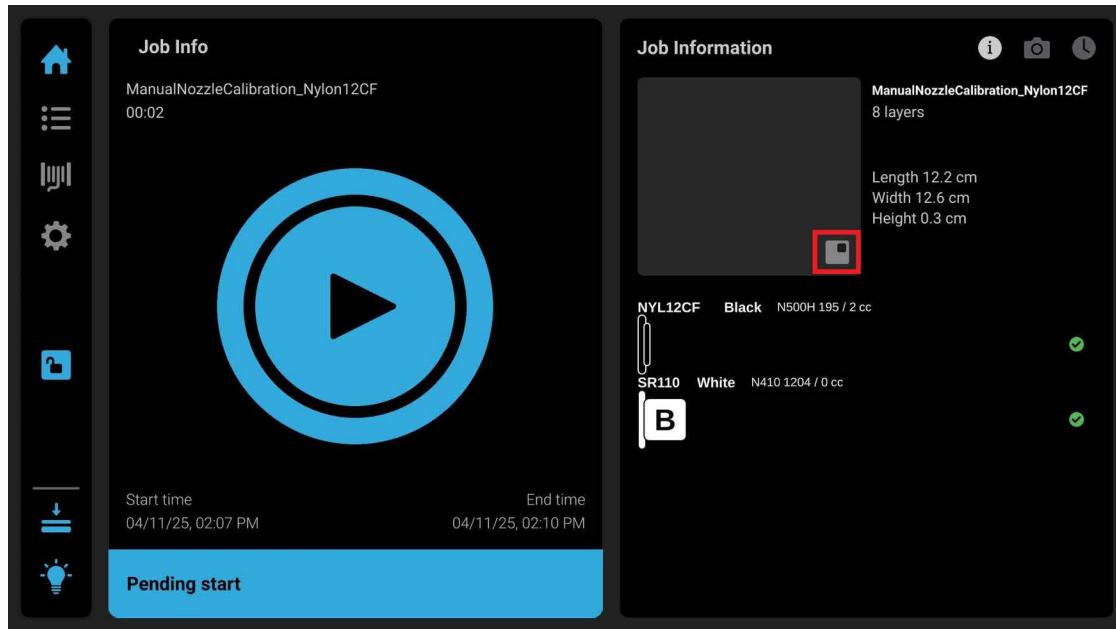
2. The manual calibration pane will display with calibration setting options. Select **Load Job** to load the calibration job to the queue.

Figure 219: Loading the Calibration Job



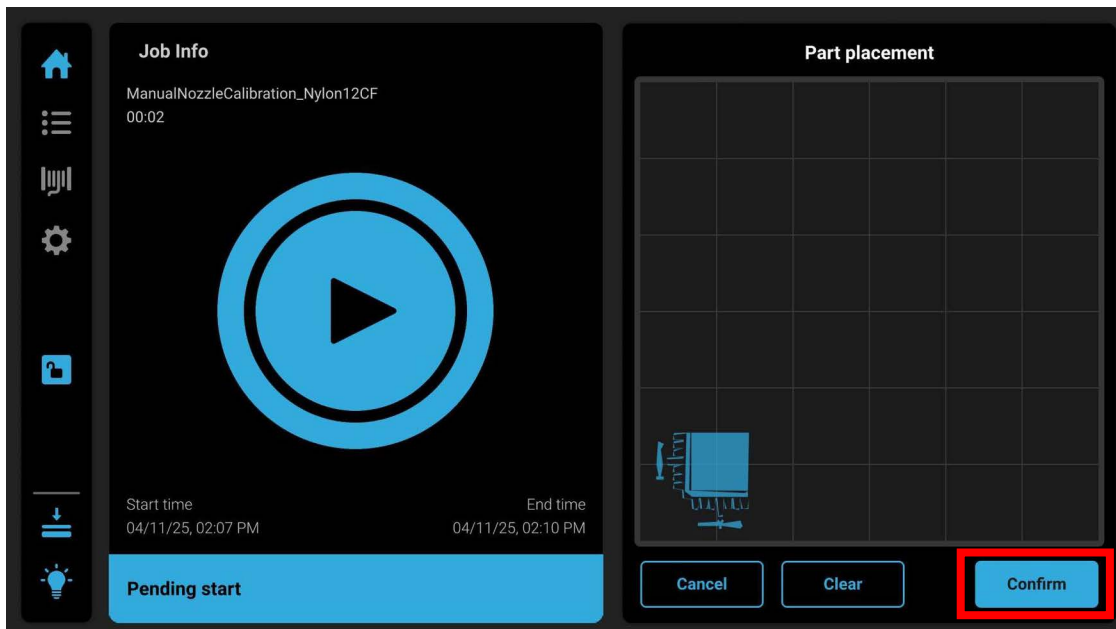
3. Navigate to the Home menu and verify that the ManualNozzleCalibration_(material name) job is ready to print. Select the Job Placement icon.

Figure 220: Home Menu, Job Placement Icon



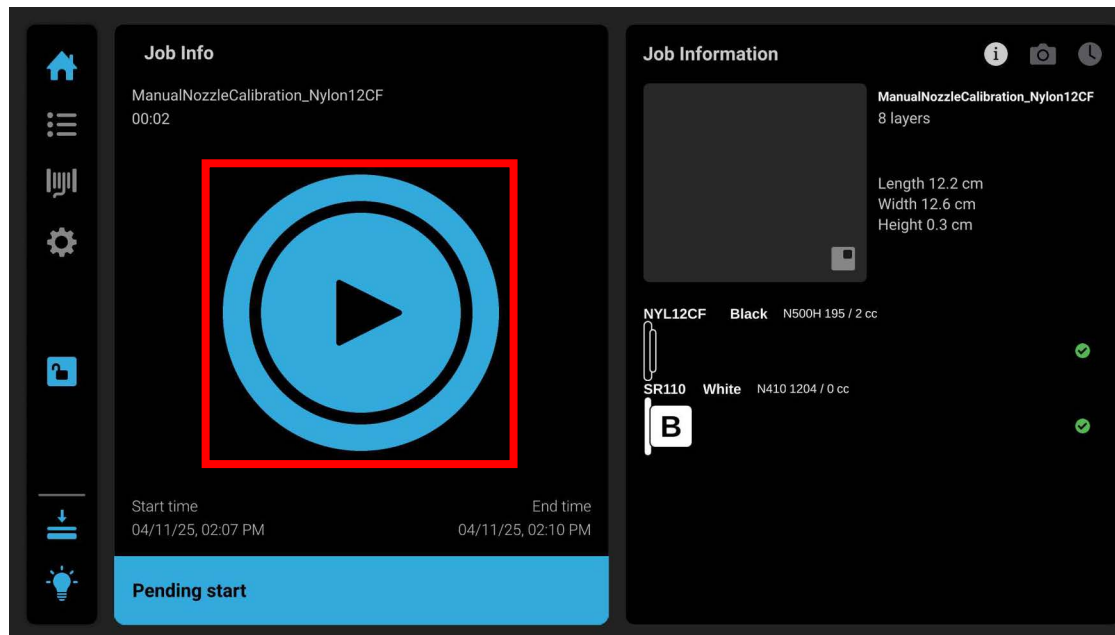
4. Move the job to the desired location on the platen and select **Confirm**.

Figure 221: Confirming the Calibration Job Location



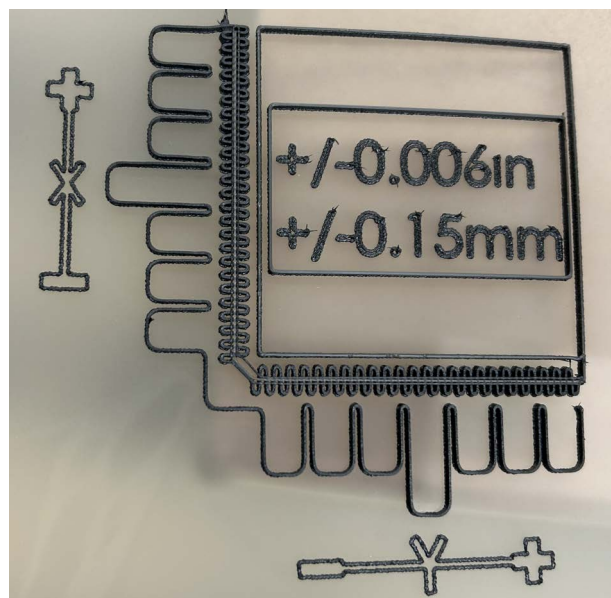
5. Ensure that Vacuum is ON and that the job is ready to start.
6. Select the **Play** button to start the calibration job.

Figure 222: Starting the Calibration Job



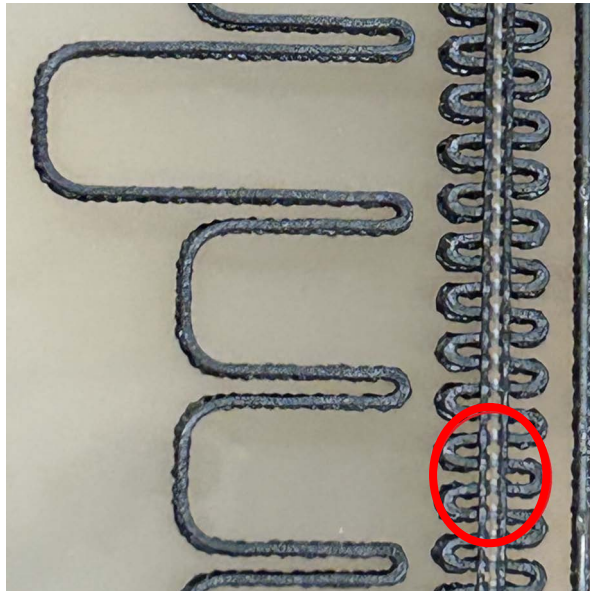
7. Allow the calibration part to finish building. When the build is complete, remove the build sheet from the printer with the calibration job build attached.
8. Use a magnifying glass to closely examine the calibration part on the build sheet.

Figure 223: Printed Calibration Part



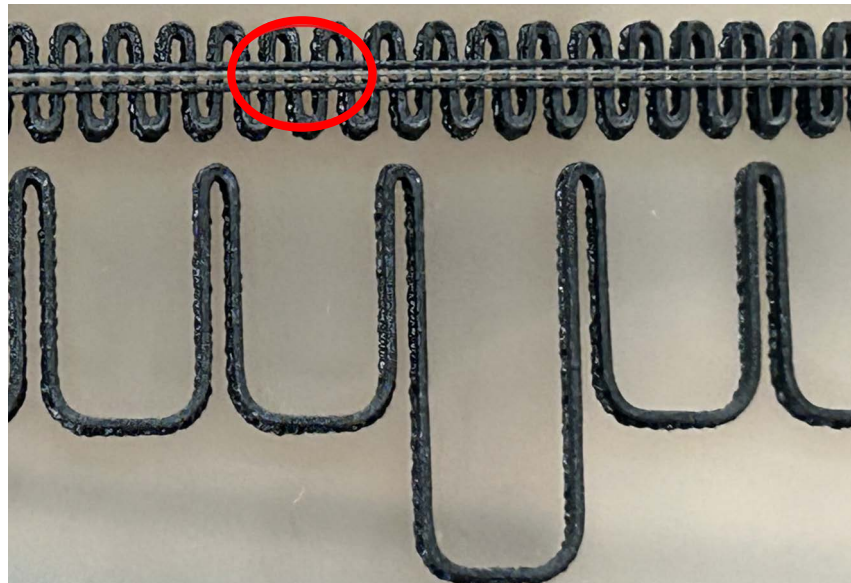
9. identify and record the XY calibration values:
 - a. Find the location along the x-axis where the support bead is best centered between the two model beads and record this value.

Figure 224: X-Axis Support Bead



- b. Find the location along the y-axis where the support bead is best centered between the two model beads and record this value.

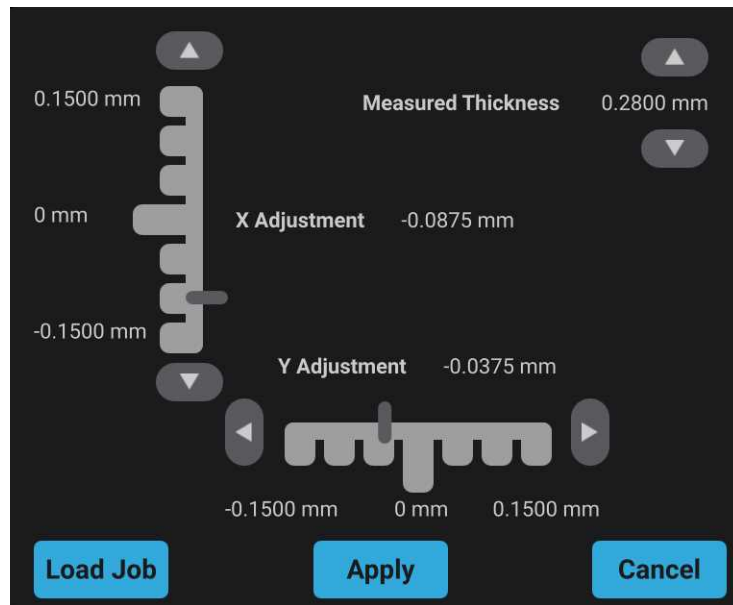
Figure 225: Y-Axis Support Bead



- c. Peel the support bead off the calibration job and measure its thickness with a caliper. Record this value.

10. From the Consumables menu, select the tool to be calibrated. Scroll down on the right side of the pane to reveal Manual Nozzle Calibration and select **Open**.
11. The manual calibration pane will display with calibration setting options.
 - Use the arrow buttons to move the X and Y Adjustment sliders to match the locations that were recorded from the printed calibration job.
 - Use the arrow buttons to change the Measured Thickness value to match the recorded bead thickness from the printed calibration job.
 - Click **Apply** to save the recorded values.

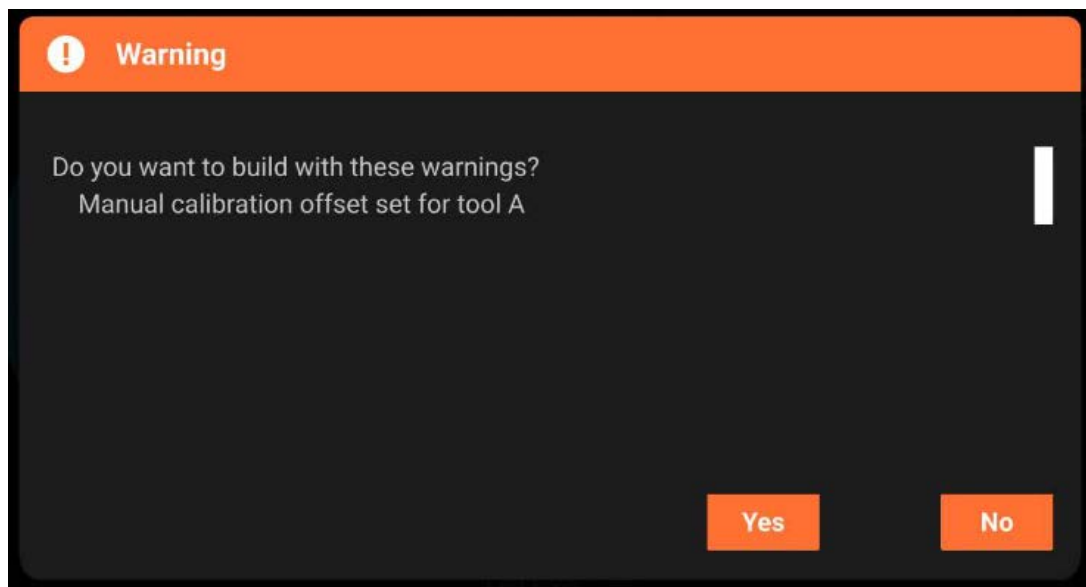
Figure 226: Entering Calibration Job Measurements



12. Repeat the steps above to build a new calibration job using the derived calibration values. Verify:
 - Values for X and Y should be centered at 0.
 - The support bead thickness should be close to 0.25mm

13. The Advanced option can be used to input known calibration values as needed. This may be necessary after a software upgrade. Selecting **Advanced** after calibrating a tool will display the current tool calibration. Selecting X, Y or Z will allow an offset to be entered to get to the desired coordinate. If XYZ offsets are manually modified, the following warning dialog will display.
- To continue with the manually modified values, select **Yes**.
 - To continue with auto-calibrated values, select **No**.

Figure 227: Manual Calibration Warning



Updating Controller Software

After placing the printer into upgrade mode (see [“Update Software” \(page 143\)](#)), Controller Software can be updated using one of the following methods:

- Navigating to the update file on your workstation PC with the Insight software application; After placing the printer into upgrade mode (see [“Update Software” \(page 143\)](#)), navigate to and install the upgrade file from its saved location on your workstation PC.
- Selecting push notifications automatically sent via GrabCAD Print; After receiving a notification from GrabCAD Print that a software upgrade is available, follow the on-screen prompts and instructions to install the upgrade.

GrabCAD Print Method

To update controller software using GrabCAD Print:

1. Confirm the printer is ready to receive a software update.
2. Open GrabCAD Print.
 - a. Searching for GrabCAD Print using the **Search** tool on the Windows toolbar.
 - b. Click GrabCAD Print in the search results.

Or-

 - c. Double-click the GrabCAD Print shortcut on the desktop if one is present.
3. Open the **Printer** panel.
4. Locate the F3300 by scrolling through the list of available printers or by using the search bar at the top of the panel.
5. Confirm the printer is locally connected. If not, add it locally.

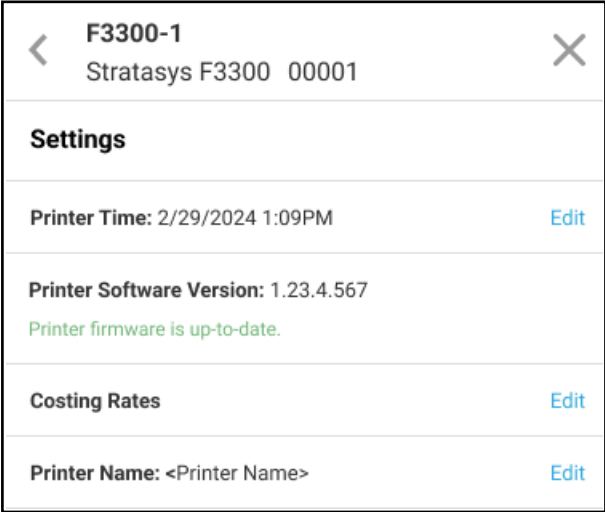


In the **Printer** panel, a cloud-connected printer displays a cloud icon to the right of the printer's name. If there is no cloud icon, the printer is locally connected.

6. Click on the gear icon on the printer's card in the **Print** panel.
7. The **Details** panel for the printer displays. Click **Settings**.
8. The **Settings Panel** displays one of the following images depending on printer status. See [Figure 228 \(page 204\)](#), [Figure 229 \(page 204\)](#), or [Figure 230 \(page 205\)](#).

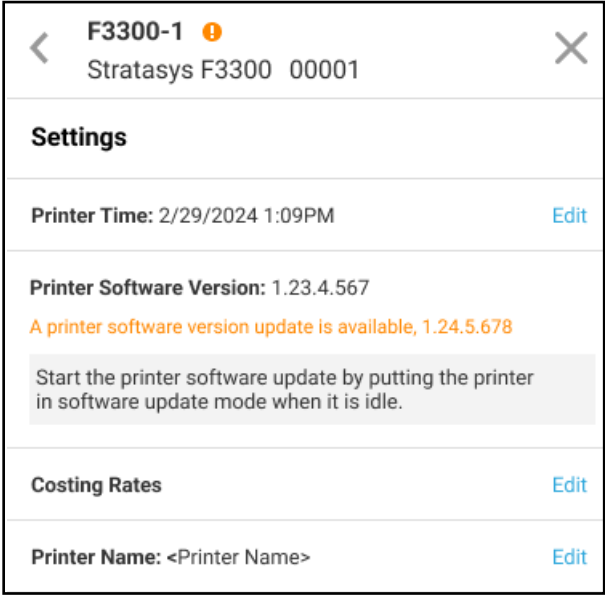
If the printer firmware version is current.

Figure 228: Printer firmware version is current



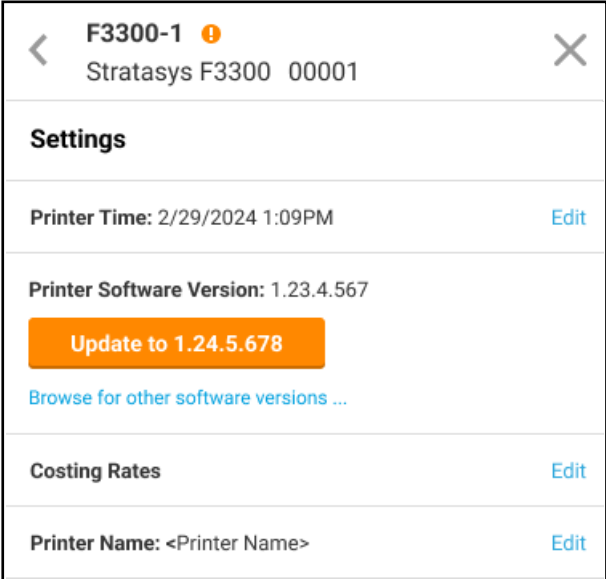
If a firmware update is available, but the printer is not in the software update state.

Figure 229: Firmware update available, but printer is not in the update state



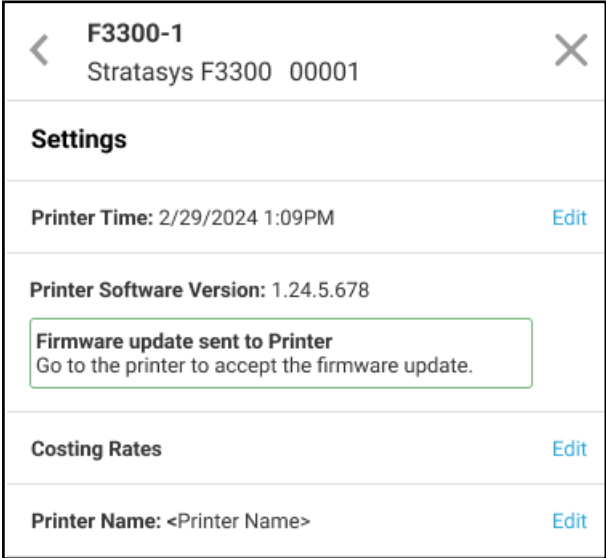
If a firmware update is available, and the printer is ready to receive it.

Figure 230: Firmware update available and printer in update state



9. GrabCAD Print displays this message when the firmware update is sent.

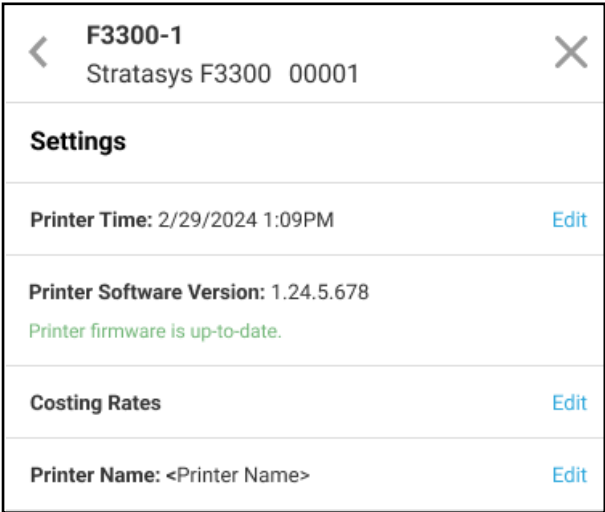
Figure 231: Firmware update sent



10. After the software has been downloaded, follow the instructions at the printer. A reboot will be required.

- 11. When the update is completed, GrabCAD Print displays the new firmware version.

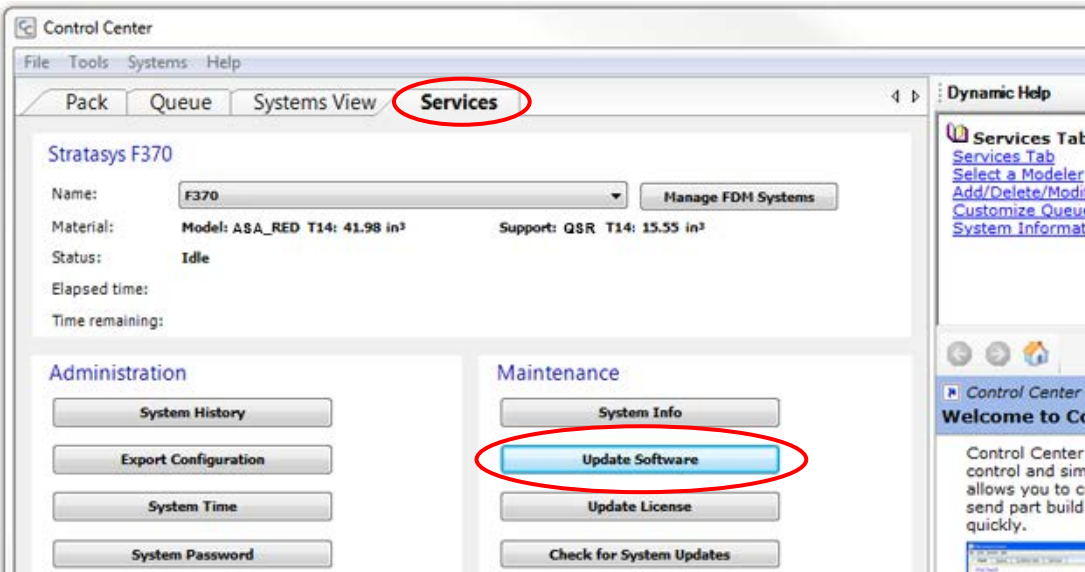
Figure 232: Firmware update complete



Control Center Software Method

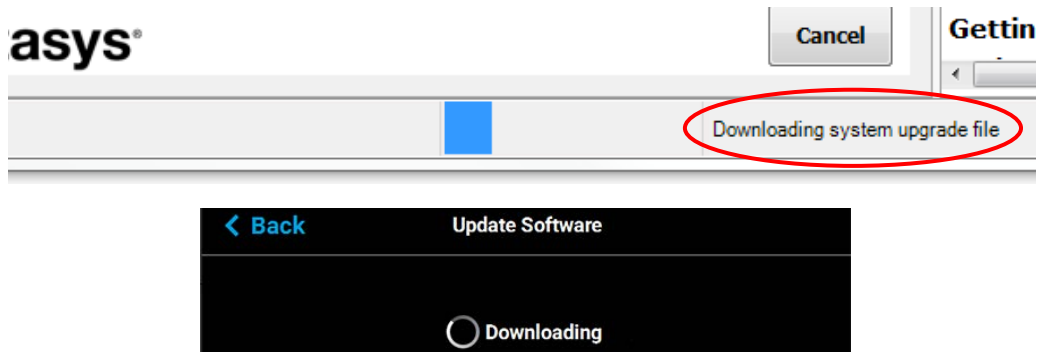
- 1. Placing the printer into upgrade mode (see “Update Software” (page 143)).
- 2. From your workstation PC’s Start Menu, navigate to **All Programs | Insight** (installed version) | **Control Center** (installed version) or double-click the Control Center shortcut (if available).
- 3. Within Control Center, select the **Services** tab. Ensure that your F3300 printer is selected from the drop-down menu then click the **Update Software** button.

Figure 233: Control Center Update Software



4. Control Center will begin establishing a connection with the printer. Once a connection is established, the workstation PC's file explorer will open.
5. Browse to the location of the .upg software upgrade file.
6. Select the *.upg file to be downloaded and then click **Open**. Control Center will begin sending software to the printer. Progress is indicated within the bottom of the Control Center window as well as on the touchscreen.

Figure 234: Software Download Progress



7. Once the software upgrade is successfully downloaded to the printer an indicator will be displayed within the bottom of the Control Center window.

Figure 235: Software Upgrade Successfully Downloaded



8. The touchscreen will refresh to indicate that the printer is verifying the upgrade file.

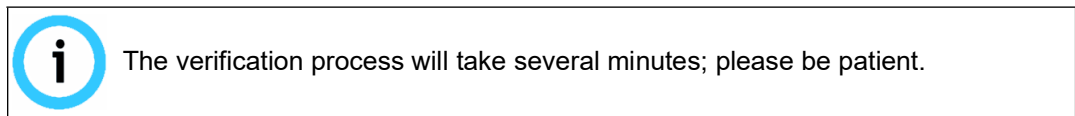
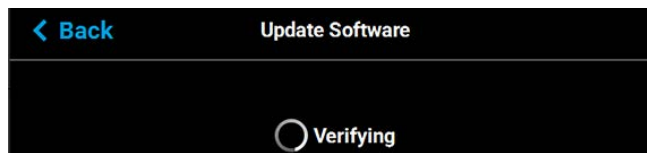
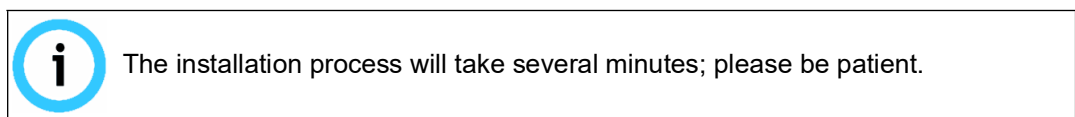


Figure 236: Verifying Software Upgrade



9. Once the verification process is complete, the printer will automatically reboot and begin installing the upgrade file. A variety of output will be displayed on the touchscreen during the installation process.



- Once the Controller Software upgrade is installed the printer will conduct its regular startup process and automatically perform an XY Gantry Calibration (see [“Powering On the Printer”](#) (page 146) for details).

Exporting System Configuration (*.CFG) File

If your system is receiving fault determination codes, you may need to export a configuration (*.cfg) file from your system to send to Customer Support. System configuration files can be exported using one of the following methods:

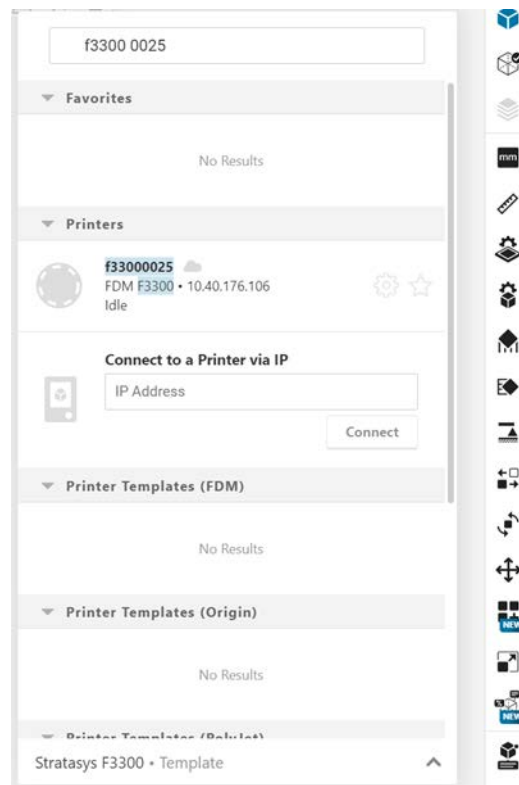
- Saving to a location on your workstation PC using the Insight software application
- Saving via GrabCAD Print

GrabCAD Print Method

To export the system configuration (.cfg) file From GrabCAD Print, perform the following procedure:

- Launch GrabCAD Print.
- Open the **Printer** dialog box and locate the desired F3300 by scrolling through the list of available printers or using the search bar at the top of the dialog box.

Figure 237: Search for printer




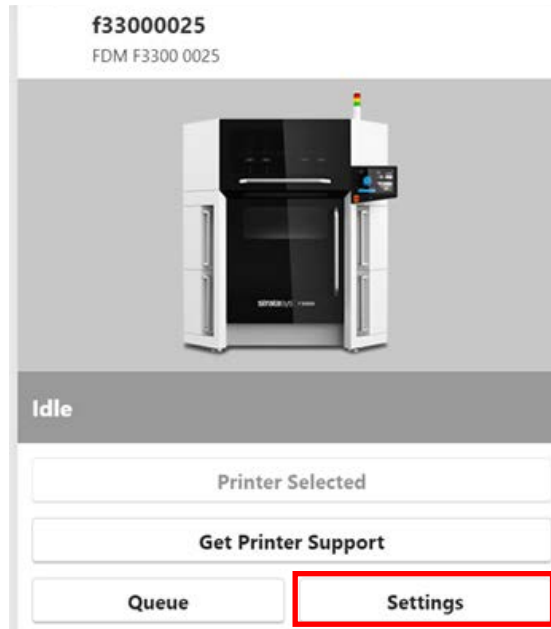
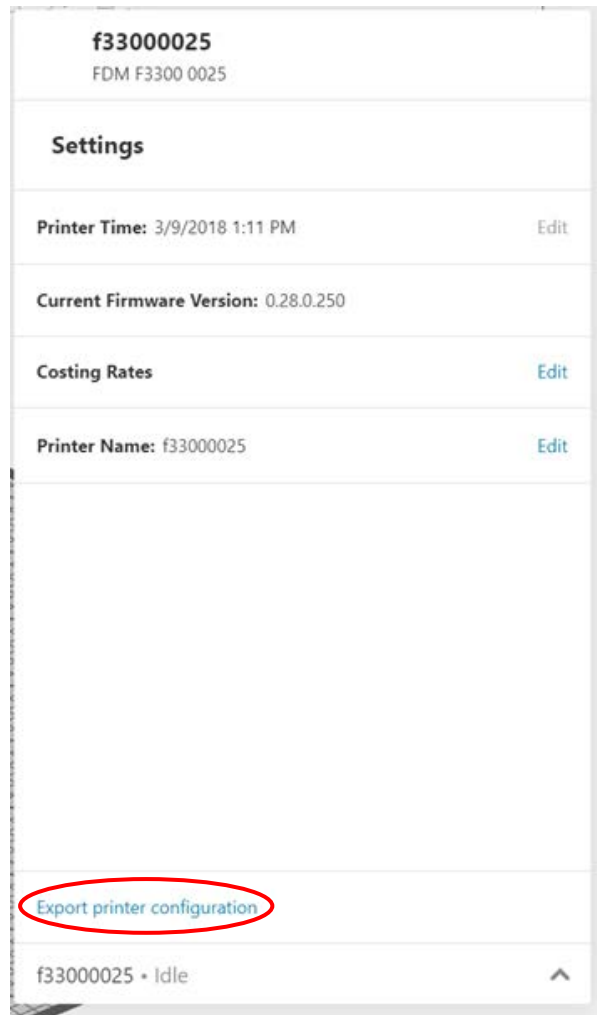
3. On the **Print** dialog box, click the gear  icon.
4. The **Details** dialog box displays. Click **Settings**.

Figure 238: Select Settings



5. The **Settings** dialog box displays. At the bottom of the **Settings** dialog box, click the **Export Printer Configuration** link.

Figure 239: Export printer configuration

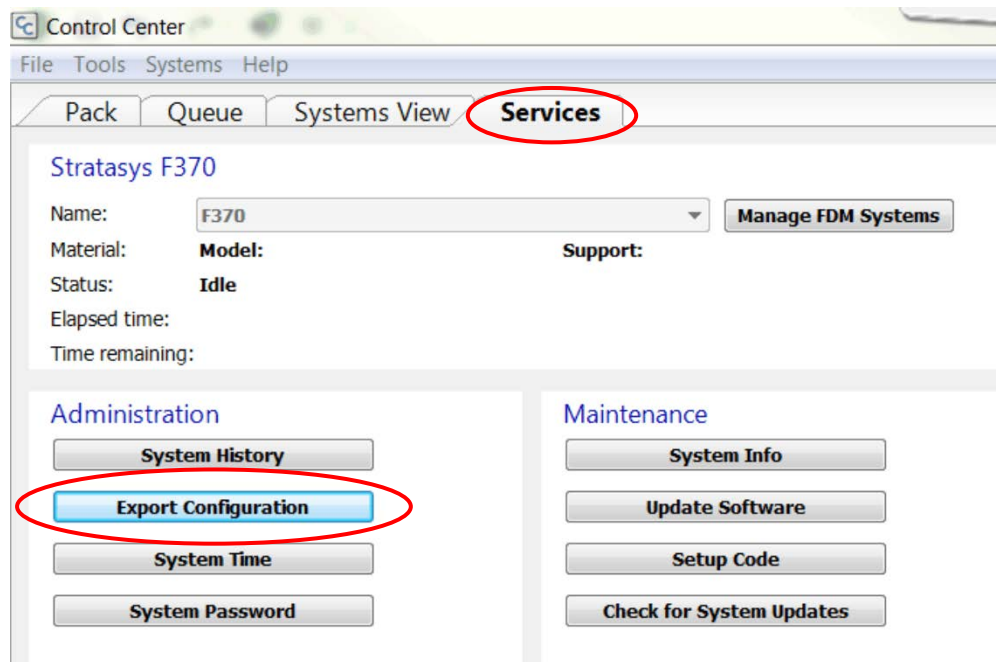


6. Browse to the directory where the configuration file will be saved.
7. Click the **Save** button.
8. Close the **Printer** dialog box and exit GrabCAD Print.

Insight Software Method

1. From your workstation PC's Start Menu, navigate to **All Programs > Insight (installed version) > Control Center (installed version)** or double-click the Control Center shortcut (if available).
2. Within Control Center, select the **Services** tab. Ensure that your F3300 printer is selected from the drop-down menu then click the **Export Configuration** button.

Figure 240: Control Center Export Configuration



3. Browse to the directory where you wish to save the configuration file.
4. Click on the **Save** button.
5. Close Control Center.

Maintenance Schedule


Warning: Hot Surface Hazard

Always wear proper heat protective gloves and clothing when handling items inside the oven, as surfaces within the oven can be very hot.

Maintenance tasks must be performed on a regular basis in order to maintain optimal system operation. [Table 15](#) outlines the general maintenance schedule for the F3300 printer. Detailed instructions for each task make up the rest of this chapter.

[Table 15: Maintenance Schedule](#)

Post Build	Weekly	Monthly	As Needed	Maintenance Task
X				Cleaning the Purge Tray
	X			"Cleaning the Oven Chamber" (page 213)
	X			"Cleaning the Platen" (page 213)
		X		"Clean/Inspect Tip Wipe Assemblies" (page 214)
		X		Cleaning the Camera Glass
			X	"Cleaning the Exterior Surface of the Printer" (page 217)
			X	"Cleaning the Touchscreen Display" (page 217)

Weekly Maintenance

Cleaning the Oven Chamber

**Warning: Hot Surface Hazard**

Always wear proper heat protective gloves and clothing when handling items inside the oven, as surfaces within the oven can be very hot.

Do not allow excess material debris to accumulate in the oven chamber as this could cause damage to the printer. Clean the oven chamber on a weekly basis to remove build material debris and dust. A standard vacuum can be used to clean this area if needed. If excessive accumulation occurs vacuum the oven chamber as needed.

Cleaning the Platen

For an overview of the platen, see [Figure 15 \(page 19\)](#). A build sheet is securely affixed to the platen by controlled vacuum. If debris collects on the platen, it can adversely affect build sheet adhesion.

1. Remove the build sheet from the platen.
 2. Carefully remove purged material debris that have fallen into the openings and vacuum channels of the platen.
- A standard vacuum can be used to clean the platen.

Monthly Maintenance

Clean/Inspect Tip Wipe Assemblies

The tip wipe assemblies should be cleaned once a month. While cleaning the assemblies, inspect the flicker/brush assemblies for wear and replace as necessary when wear is detected.

Once material is purged from a tip, the flicker portion of the tip wipe assembly passes across the tip's opening, cutting purged material off in small segments. The brush portion of the tip wipe assembly then passes across the tip's opening cleaning the tip and its tip shield. As a result, the flicker will wear at the location where the tip contacts its surface and eventually develop a notch large enough for the tip to completely pass through the flicker; a notched flicker cannot properly cut purging material. Similarly, material can become embedded within the bristles of the brush resulting in clumping; clumped bristles cannot properly clean a tip or its tip shield. The tip wipe assembly should be replaced once a significant notch develops within the flicker portion of the assembly or whenever bristle clumping (which cannot be removed with a brush) is apparent within the brush portion of the assembly. The tip wipe assembly is replaced as a single unit.

To clean the tip wipe assembly and inspect its components:

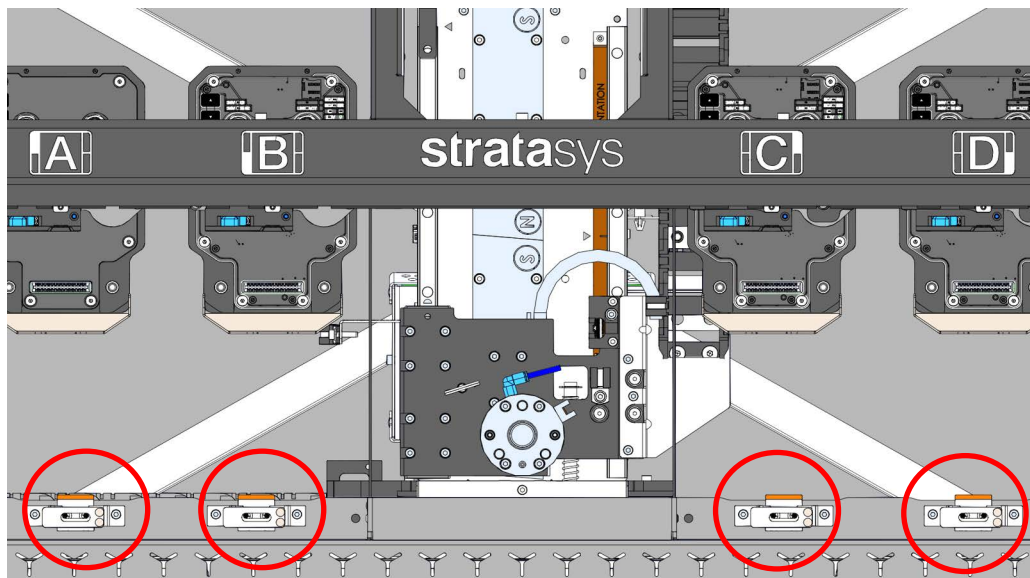
1. Ensure that the printer is stopped (idle) and is not building.
2. Navigate to the **Consumables** menu and press the Hood unlock icon.
3. Open the top hood.



Caution: Hot Surfaces

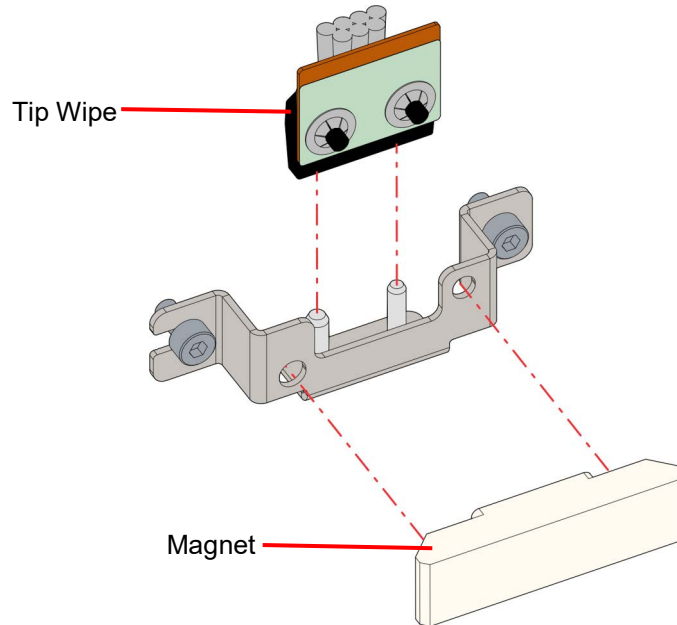
Depending on how long the oven has been allowed to cool, components may be hot. Wear the safety gloves provided in the Welcome Kit to perform all remaining steps.

Figure 241: Tip Wipe Locations



4. Remove the retaining magnet from the front of the tip wipe mounting bracket. Lift straight up to remove the tip wipe.

Figure 242: Removing a Tip Wipe



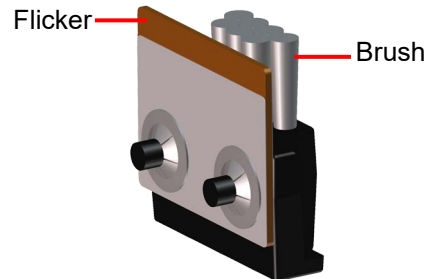
5. Repeat [step 4](#) to remove any other tip wipe assembly that requires replacing.
6. Clean and inspect the surface around the locating pins. Make sure that the tip wipe assemblies can sit flush on the surface. If required, use shop or compressed air to blow out the area. A brush may also be used to clean the area. Ensure there is no debris that could shift the tip wipe brush assembly.
7. Inspect the flicker portion of the tip wipe assemblies. The top edge of the flicker should be straight and must not contain excessive notching/wear.
8. Inspect the brush portion of the tip wipe assemblies. Brush bristles must not show evidence of wear (i.e. no notches in bristle pattern) and should not contain significant bristle clumping. Frayed bristles are acceptable as long as the top edge is even across all of the bristles.

9. Replace one or both of the tip wipe assemblies if excessive wear is present.



The components of the assembly cannot be replaced individually. The entire tip wipe assembly must be replaced if excessive wear is present on the flicker or the brush.

Figure 243: Tip Wipe Assembly Detail



10. Reinstall the support side tip wipe assembly by placing the assembly onto its locating pins and sliding the assembly downward.
11. Repeat [step 10](#) above to reinstall the model side tip wipe assembly.

As Needed Maintenance

Cleaning the Exterior Surface of the Printer

The printer's exterior surfaces (doors and panels) may accumulate dust and periodically require cleaning. Exterior doors and panels, with the exception of the touchscreen display, can be cleaned using a slightly damp microfiber cloth (supplied in the Welcome Kit). The cloth should be only slightly damp to ensure that water does not enter the printer. Excess water can cause damage to interior components.

Cleaning the Touchscreen Display

**Caution:**

Using a cleaner which contains ammonia and/or alcohol can damage the touchscreen. Only a suitable LCD cleaning solution and microfiber cloth (included in the Welcome Kit) should be used to clean the touchscreen display.

As needed, to remove smudge marks and buildup, clean the touchscreen display using the LCD cleaner and microfiber cloth provided in the Welcome Kit.

Apply an adequate amount of LCD cleaning solution to the provided microfiber cloth and then gently wipe the exterior surface of the touchscreen display to clean its surface. It is recommended that you apply LCD cleaner to the microfiber cloth rather than applying cleaner directly to the touchscreen display, as excess moisture may damage the display.

Service Level Preventive Maintenance (PM)

Preventative maintenance by qualified personnel is recommended at a yearly interval.

Required Items

- Kit, PM 12 Month F3300 (413627-000X-S)
 - Filter, Vacuum Element Qty 1 (104279-000X)
 - Pin, Dowel, 3mm X 16mm, Alloy Steel, Black Oxide Qty 24 (410907-000X)
 - Screw, FHT M3x0.5x8 BZ SL PR Qty 24 (410908-000X)
 - Tip Seal Assy, X-Bellows Qty 1 (412230-000X)
 - Assy, Tip Wipe 120C Qty 4 (950595-000X)
- Kit, PM 24 Month F3300 413839-00X-S
 - Battery, Coin, 3.0V, Lith, 20.0mm, 225MAH Qty 2 (401324-000X)
 - Filter, 5 Micron, Size 40, 1/2 BSPT Qty 1 (407154-000X)
 - Filter, 0.01 Micron, Size 40, 1/2 BSPT Qty 1 (407155-000X)
 - Tube, Filament, Lower Bay to Accumulator, Qty 2 (410362-000X)
 - Tube, Filament, Upper Bay to Accumulator Qty 2 (410363-000X)
 - Tube, Umbilical, Filament Inner Qty 4 (411401-000X)
 - Material Drive Qty 4 (409080-000X)
 - Tube, Vacuum, Platen Qty 1 (409553-0002)
- Grease 1/2 OZ, Mobil (413696-000X-S required for 12 Month PM)
- Grease AFF 70 Grams (951390-000X-S required for 24 Month PM)
- Tool Kit (Pins and Hardware) 410611-000X-S

One Year PM Recommendations

At one year intervals, replacing the following items is recommended:

- Filter, Vacuum Element Qty 1 (104279-000X)
- Tip seal assy, X bellows 412230-000X
- Assy, Tip wipe 120C 950595-000X (Quantity 4)

At one year intervals, cleaning or inspecting the following items is recommended:

- Perform the QC master clean and lubricate using the procedure in the F3300 service manual.
- Perform the tool side QC kit maintenance.
- Clean pins (410611-000X-S) yearly and replace the pins every five years.
- Inspect the oven Z seals. Replace if necessary.
- Inspect the air filters. Replace if necessary.

- Clean all glass surfaces.
- Inspect all glass surfaces such as the interior and exterior viewing windows.
- Clean the camera glass windows within the oven, front and rear.

Vacuum and clean debris from the following:

- The oven chamber
- Above the bellows, paying special attention to the area inside the tip seal well.
- The LZ surfaces
- The XY rail surfaces

Two Year PM Recommendations

Required Items

Perform all items listed in [“One Year PM Recommendations” \(page 218\)](#).

At two year intervals, replace the following:

- Filter 5 Micron, size 40, 1/2 BSPT, N.O. Auto Drain, Rev Flow with service indicator (407154-000X)
- Filter 0.01 Micron, Size 40, 1/2 BSPT, N.O. Auto Drain, Rev Flow with service indicator (407155-000X)
- Assy, Head Motor, Cust Enc. X4 all bays (410699-000X)
- TOB Battery (401324-000X)
- EXP SBC Battery (401324-000X)
- Tube, Filament, Lower Bay to Accumulator, Qty 2 (410362-000X)
- Tube, Filament, Upper Bay to Accumulator Qty 2 (410363-000X)
- Tube, Umbilical, Filament Inner Qty 4 (411401-000X)

At two year intervals, clean and lubricate the following:

- Following the procedure in the F3300 service manual, clean and lubricate the X bearings and rails using grease AFF 70 Grams 951390-000X-S.
- Following the procedure in the F3300 service manual, clean and lubricate the Y bearings and rails using grease AFF 70 Grams 951390-000X-S.
- Following the procedure in the F3300 service manual, clean and lubricate the LZ bearings and rails using grease AFF 70 Grams 951390-000X-S.
- Use the following required grease: Grease AFF 70 Grams (951390-000X-S)

Five Year PM Recommendations

Required Items

- Lubricate the Z ball screws.
- Replace pins (410611-000X-S)

Safety Verification

- Verify that neither the door nor the hood can be opened while the printer is building or there is motion along axis. See the F3300 service manual for details.
- Verify that the E-stop works properly and prevents motion of all axis. See the F3300 service manual for details.

Customer Replaceable Units

The following service procedures outline the replacement instructions for the customer replaceable units of the printer.

Material Bay Drive Assembly

Required Tools

- 2.5 mm hex wrench

Removing the Material Bay Drive Assembly

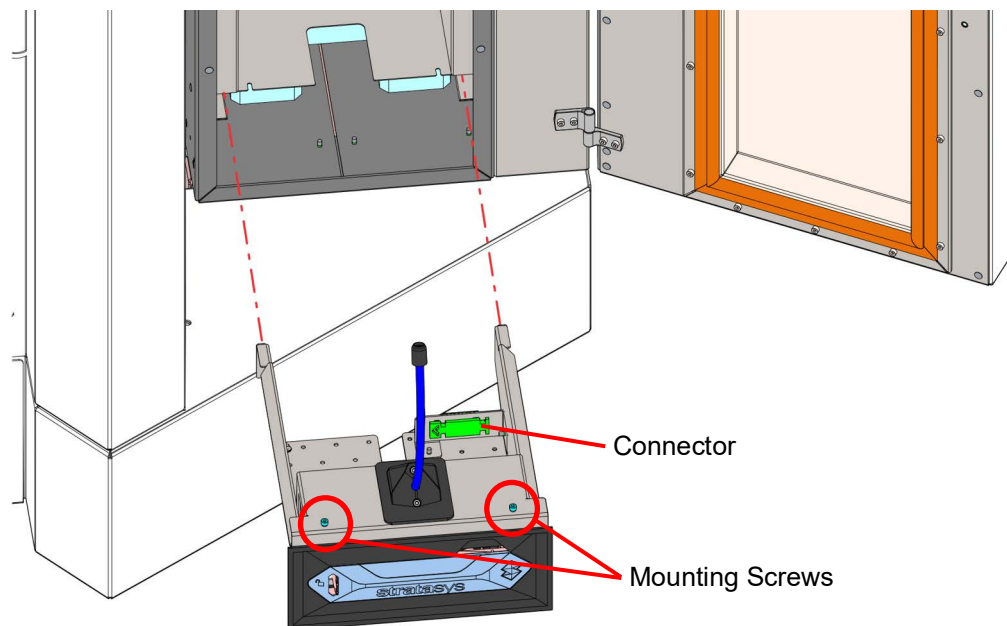
1. Unload material.
2. Power OFF the printer. See [“Powering Off the Printer”](#) (page 149).



Always perform lockout-tagout of the AC power cord in accordance with customer site procedures.

3. Open the material bay door.
4. Remove the material spool from the material bay.
5. Using a 2.5 mm hex wrench, loosen the screws (2) that secure the drive assembly.
6. Pull the drive assembly forward slightly to disengage from the connector.
7. Remove the filament tube connected to the back of the drive assembly.
8. Remove the drive assembly from the material bay.

Figure 244: Material Bay Drive Assembly Detail



Installing the Material Bay Drive Assembly

1. Slide the drive assembly partially in to the material bay. See [Figure 244](#).
2. Insert the material tube through the hole in the drive assembly bracket.
3. Push the end of the material tube into the fitting on the drive assembly.
4. Push in the drive assembly until the connector is engaged.



Caution:

Make sure that the material tube is routed away from the connector to prevent obstruction of the filament path.

5. Tighten the drive assembly mounting screws (2). Tighten the screws to XX nm (XXin-lbs).

Filament Tubes - Upper

Tools Required

- Cutters
- 2.5 mm hex wrench

Removing the Filament Tubes

1. Unload material from the extruder assembly.
2. Power OFF the printer. See [“Powering Off the Printer” \(page 149\)](#).

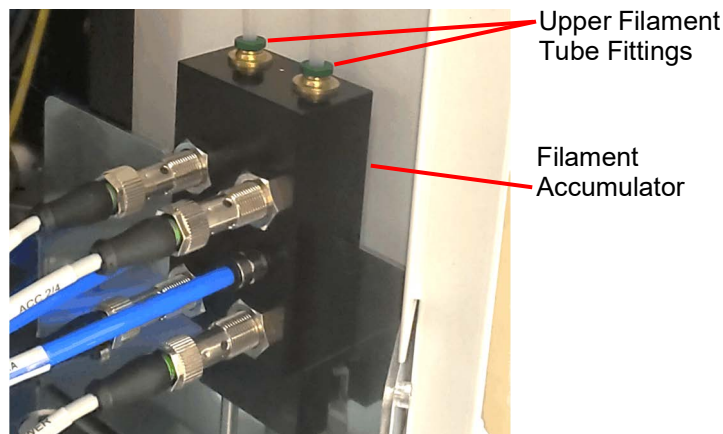


Warning: Electric Shock Hazard

Always perform lockout-tagout of the AC power cord in accordance with customer site procedures.

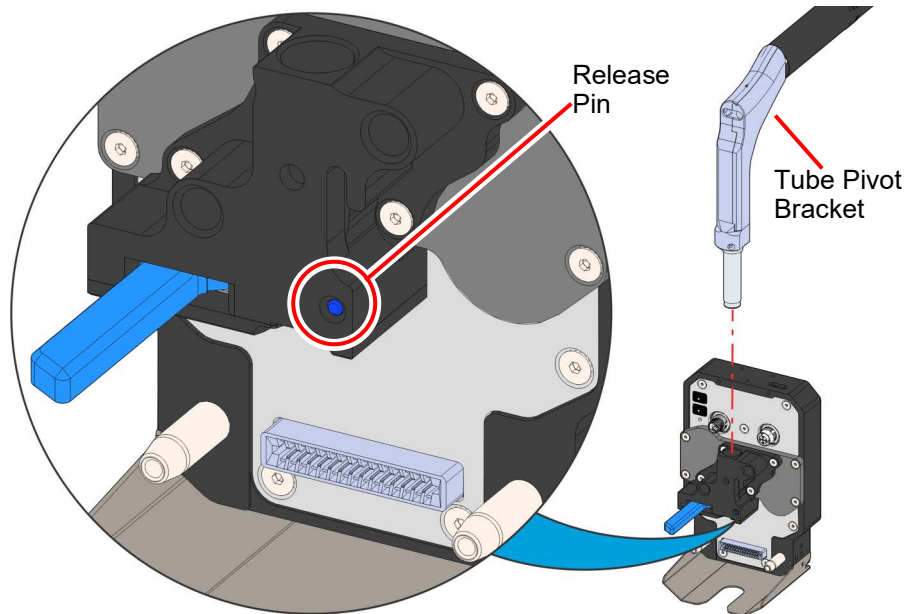
3. Open the tool hood.
4. Open the appropriate side access door for access to the filament accumulator.
5. At the top of the filament accumulator, depress the press-to-connect fitting ring to release and disconnect the appropriate upper filament tube.

Figure 245: Accumulator Upper Filament Tube Connections (Right Side Shown)



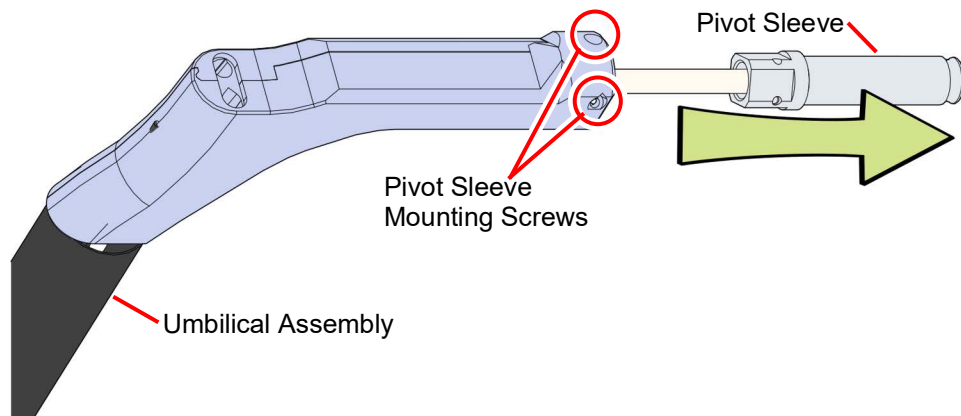
6. Remove the upper filament tubing from any existing tie wraps.
7. With the tool base still on the tool rack, push and hold the blue release pin on the tool base while pulling up on the tube pivot bracket. Remove the pivot bracket from the tool base.

Figure 246: Releasing the Pivot Bracket



8. Using a 2.5mm hex wrench, remove two screws (2) securing the pivot sleeve to the umbilical assembly. See Figure 247.
9. Pull the pivot sleeve out to expose the filament tube. See Figure 247.
10. Continue to gently pull the pivot sleeve and upper filament tube until it is completely removed from the printer material path.

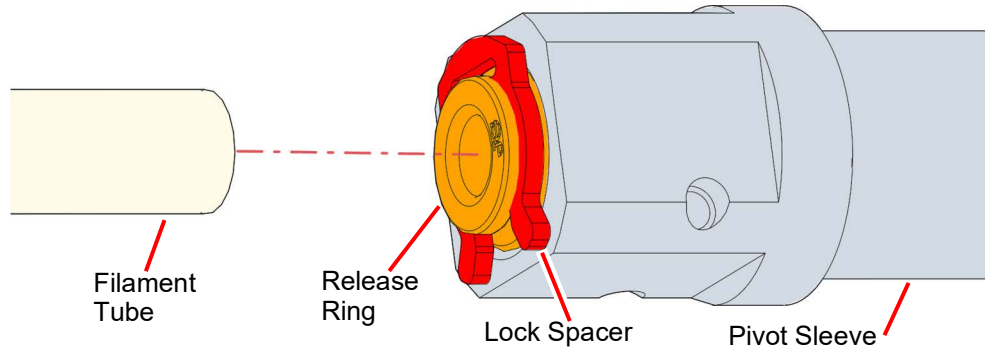
Figure 247: Pivot Sleeve Mounting Detail



11. Remove the red lock spacer beneath the fitting release ring on the pivot sleeve.

- Depress the filament tube release ring to disconnect the tubing from the pivot sleeve.

Figure 248: Filament Tube Release Detail



Installing the Filament Tube - Upper

- Transfer the pivot sleeve to the new filament tube.
- Press the filament tube as far as it will go into the sleeve and install the red lock spacer to lock it in place. See [Figure 248](#).
- Slide the free end of the tube into the material path sleeve of the umbilical assembly. See [Figure 247](#).
- Push the filament tube until it enters the accumulator area. Gently pull the free end of the filament tube to ensure that it can reach the fitting on top of the accumulator.
- Replace all tie wraps to the filament tubing.
- Connect the filament tube to the top of the accumulator at the press-to-connect fitting. See [Figure 245](#).
- At the pivot sleeve end of the tubing, use a 2.5mm hex wrench to fasten the screws (2) securing the pivot sleeve to the umbilical assembly. See [Figure 247](#).
- From the tool base, insert and push down on the pivot bracket while depressing the release pin. Release the pin to lock the bracket in place. See [Figure 246](#).
- Close the tool hood and the service access doors.

Extruder Drive Motor

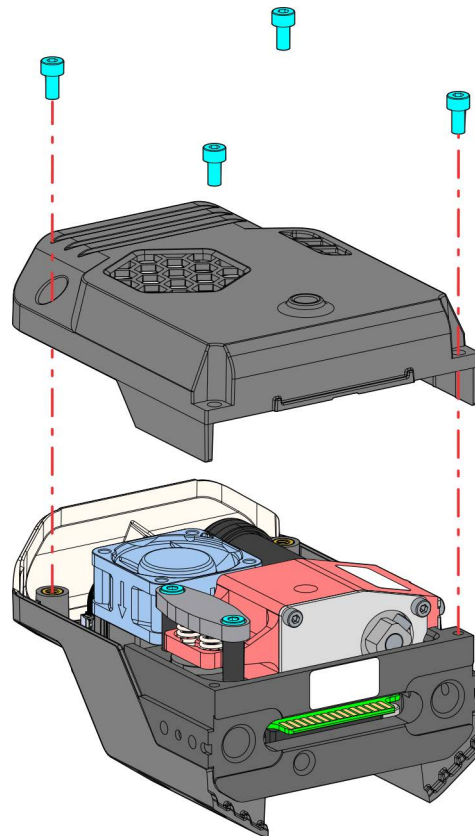
Tools Required

- 3 mm hex wrench
- 2.5 mm hex wrench

Removing the Extruder Drive Motor

1. Remove the extruder assembly from the printer as described in [“Exchanging the Hot End Assembly”](#) (page 174).
2. Using a 3 mm hex wrench, remove the screws (4) securing the top cover to the extruder drive assembly. Remove the cover to expose the motor components.

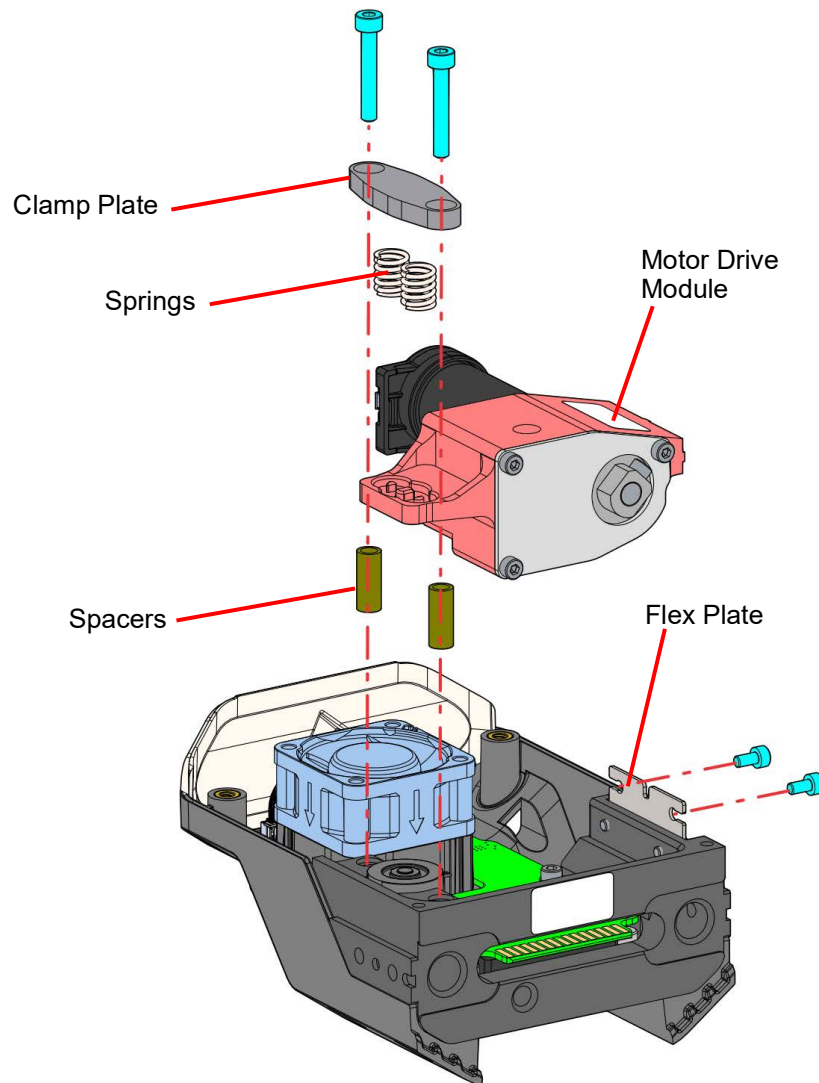
Figure 249: Extruder Assembly Top Cover Detail



3. Disconnect the motor cable at the motor connector.

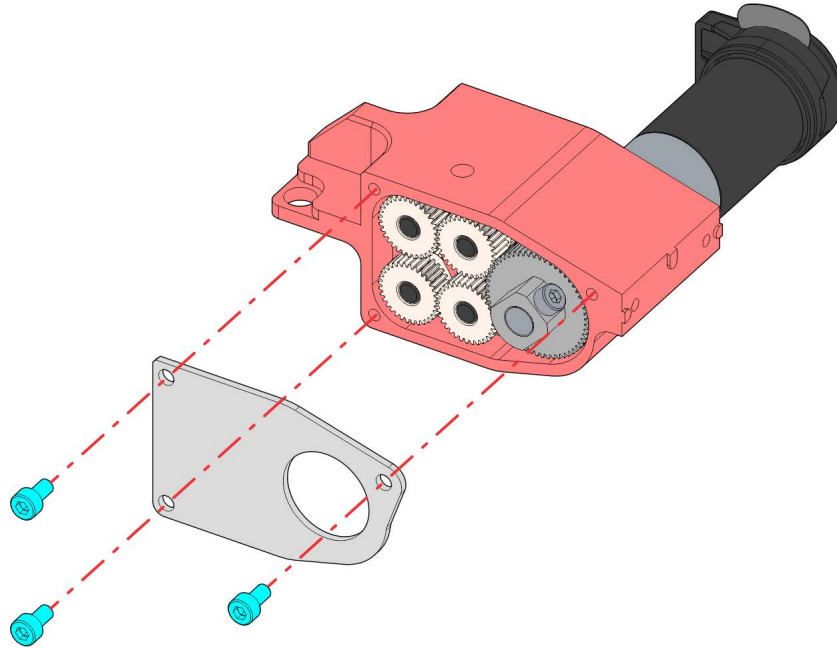
4. Using a 2.5 mm hex wrench, remove the screws (2) securing clamp plate and springs (2) to the top of the motor drive module.
5. Using a 2.5 mm hex wrench, remove the screws (2) securing the side of the motor drive module to the flex plate.
6. Remove the motor and drive module from the extruder assembly.
7. Retain the clamp plate, springs and spacers for reassembly.

Figure 250: Extruder Assembly Motor Drive Mounting Screws Detail



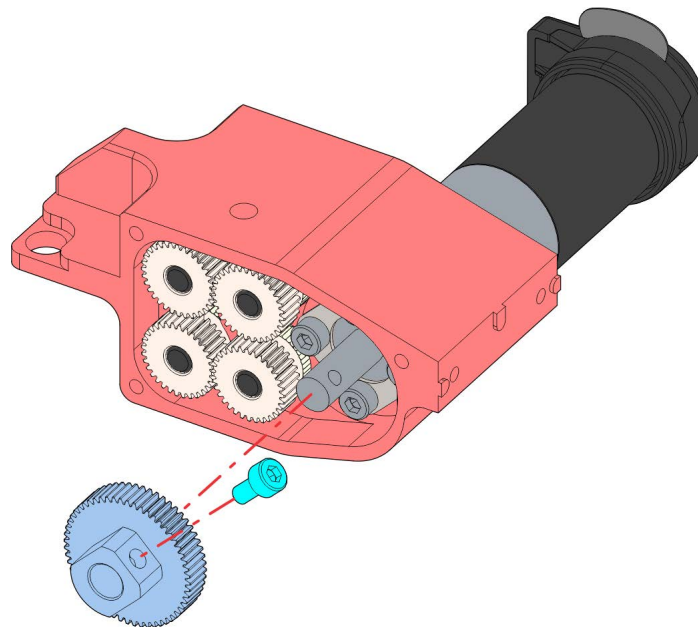
- Using a 2.5 mm hex wrench, remove the screws (3) securing the transparent cover to the drive module.

Figure 251: Motor Drive Cover Detail



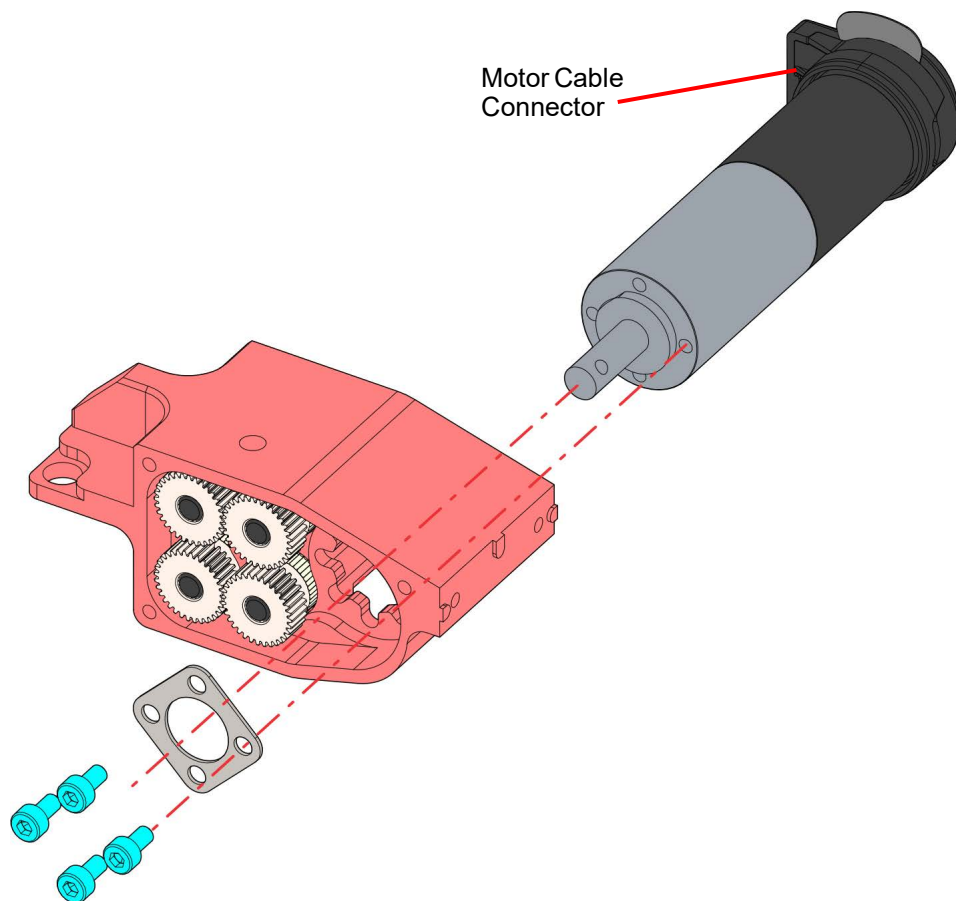
- Using a 2.5 mm hex wrench, remove the screw securing the drive gear to the motor. Remove the gear from the motor shaft.

Figure 252: Extruder Drive Motor Gear Detail



- Using a 2.5 mm hex wrench, remove the screws (4) securing the motor to the drive module washer plate.

Figure 253: Drive Module Washer Plate Detail



- Remove the motor from the drive module.

Installing the Extruder Drive Motor

1. Using a 2.5 mm hex wrench, fasten the screws (4) securing the motor to the drive module washer plate. Tighten to 1.02 nm (9 in-lbs). See [Figure 253](#).



Orient the motor cable connector as shown.

2. Using a 2.5 mm hex wrench, fasten the screw securing the drive gear to the motor shaft. Tighten to 1.02 nm (9 in-lbs). See [Figure 252](#).
3. Using a 2.5 mm hex wrench, fasten the screws (3) securing the transparent cover to the drive module. Tighten to 0.68 nm (6 in-lbs). See [Figure 251](#).
4. Install the spacers (2) to the mounts for the motor drive module. See [Figure 250](#).
5. Using a 2.5 mm hex wrench, fasten the screws (2) securing the side of the motor drive module to the flex plate. Tighten to 1.02 nm (9 in-lbs). See [Figure 250](#).
6. Using a 2.5 mm hex wrench, fasten the screws (2) securing the clamp plate and springs to the top of the motor drive module. Tighten to 2.37 nm (21 in-lbs). See [Figure 250](#).
7. Connect the motor cable to the motor connector.
8. Using a 3 mm hex wrench, fasten the screws (4) securing the top cover to the extruder drive assembly. Tighten to 1.36 nm (12 in-lbs). See [Figure 249](#).
9. Install the extruder assembly to the printer as described in [“Exchanging the Hot End Assembly” \(page 174\)](#).

Extruder Drive Fan

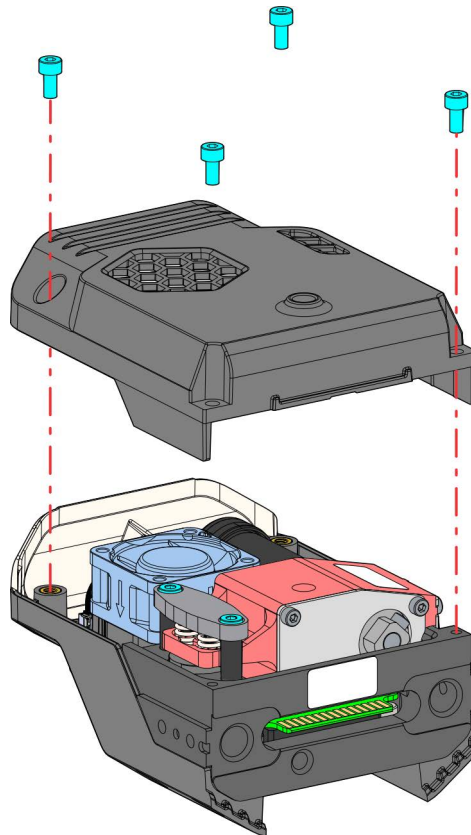
Tools Required

- 3 mm hex wrench

Removing the Extruder Drive Fan

1. Remove the extruder assembly from the printer as described in [“Exchanging the Hot End Assembly” \(page 174\)](#).
2. Using a 3 mm hex wrench, remove the screws (4) securing the top cover to the extruder drive assembly. Remove the cover to expose the motor components.

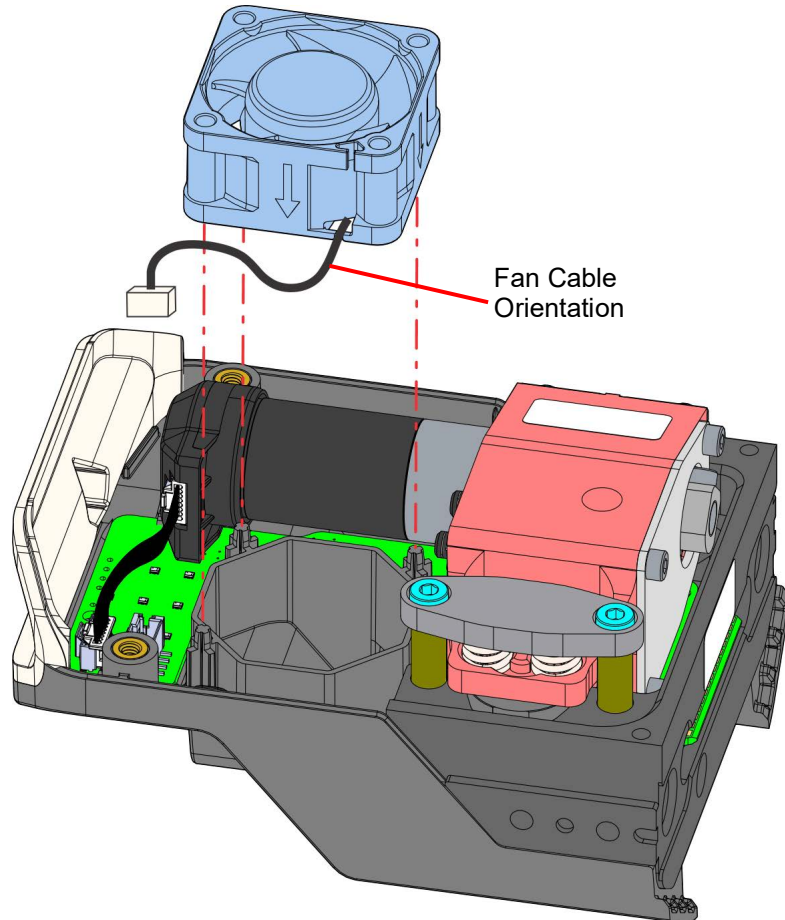
Figure 254: Extruder Assembly Top Cover Detail



3. Disconnect the extruder drive fan cable from the extruder assembly board.

- Remove the fan from the extruder assembly.

Figure 255: Extruder Drive Fan Detail



Installing the Extruder Drive Fan

- Seat the fan into the base of the extruder assembly. Align the fan mounting holes with the posts. Orient the fan with the cable in the direction shown. See [Figure 255](#).



Fan orientation is critical for air flow. Make sure that the fan label and cable are on the bottom of the fan to ensure that airflow is in the correct direction. Confirm that the arrow on the fan case is pointing down toward the base of the extruder assembly.

- Connect the fan cable to the extruder assembly board connector.
- Using a 3 mm hex wrench, fasten the screws (4) securing the top cover to the extruder drive assembly. See [Figure 254](#).
- Install the extruder assembly to the printer as described in “[Exchanging the Hot End Assembly](#)” (page 174).

Build Chamber Cameras

The following procedure describes temporary disconnection of the F3300 printer build chamber cameras. If permanent removal of the cameras is required, contact your regional Stratasys support center.

Tools Required

- #2 Phillips Screwdriver
- Step Ladder (optional)

Procedure

1. Power OFF the printer. See [“Powering Off the Printer” \(page 149\)](#).

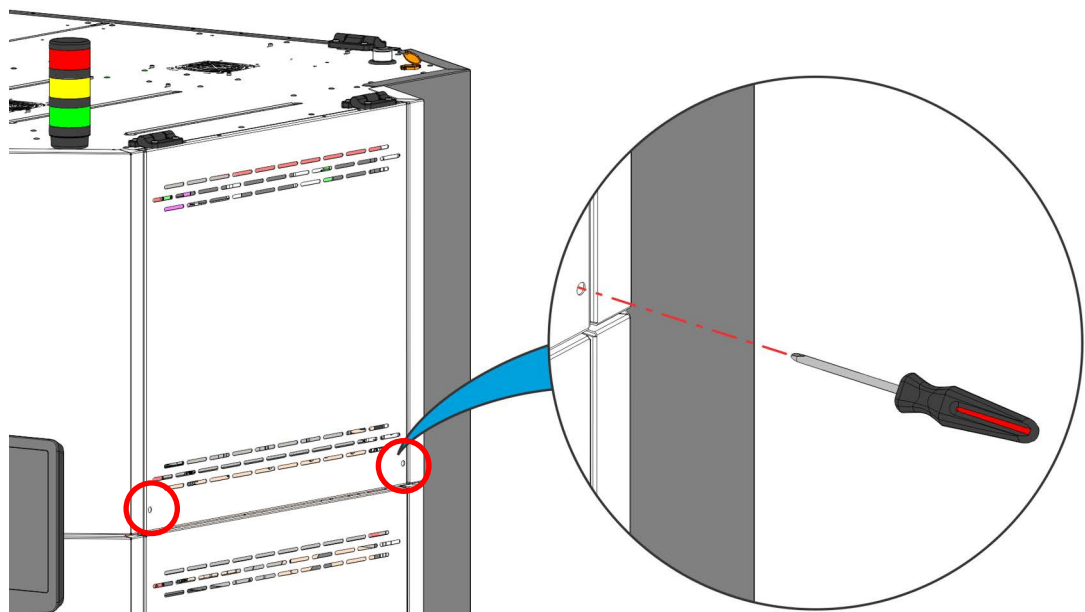


Warning: Electrical Shock Hazard

Always perform lockout-tagout of the AC power cord in accordance with customer site procedures.

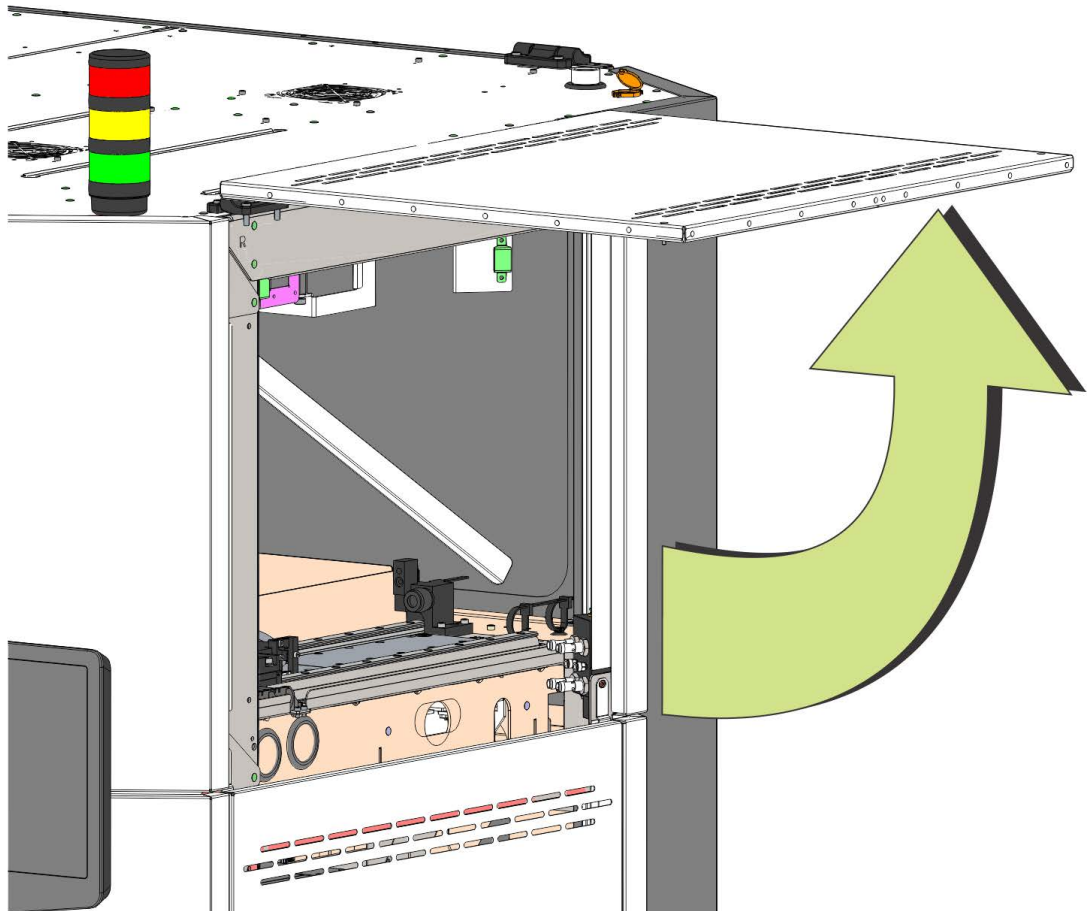
2. Open the right side top service access door. Using a # 2 Phillips screwdriver, loosen the captive screws (2) that secure the service access door.

Figure 256: Top Right Service Access Door Captive Screw Locations



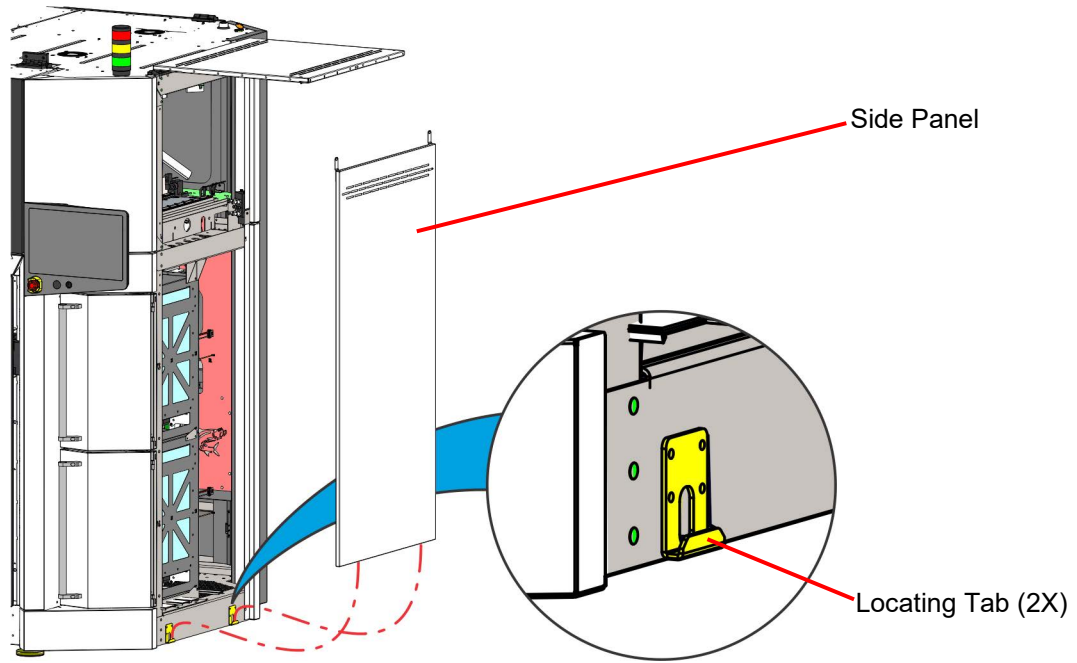
3. Lift the service access door. The friction hinge will prevent the door from falling.

Figure 257: Opening the Service Access Door



4. Pull the top of the right side panel away from the printer to disengage the magnets and lift it to detach it from the locating tabs at the bottom of the printer frame.

Figure 258: Side Panel Mounting Detail



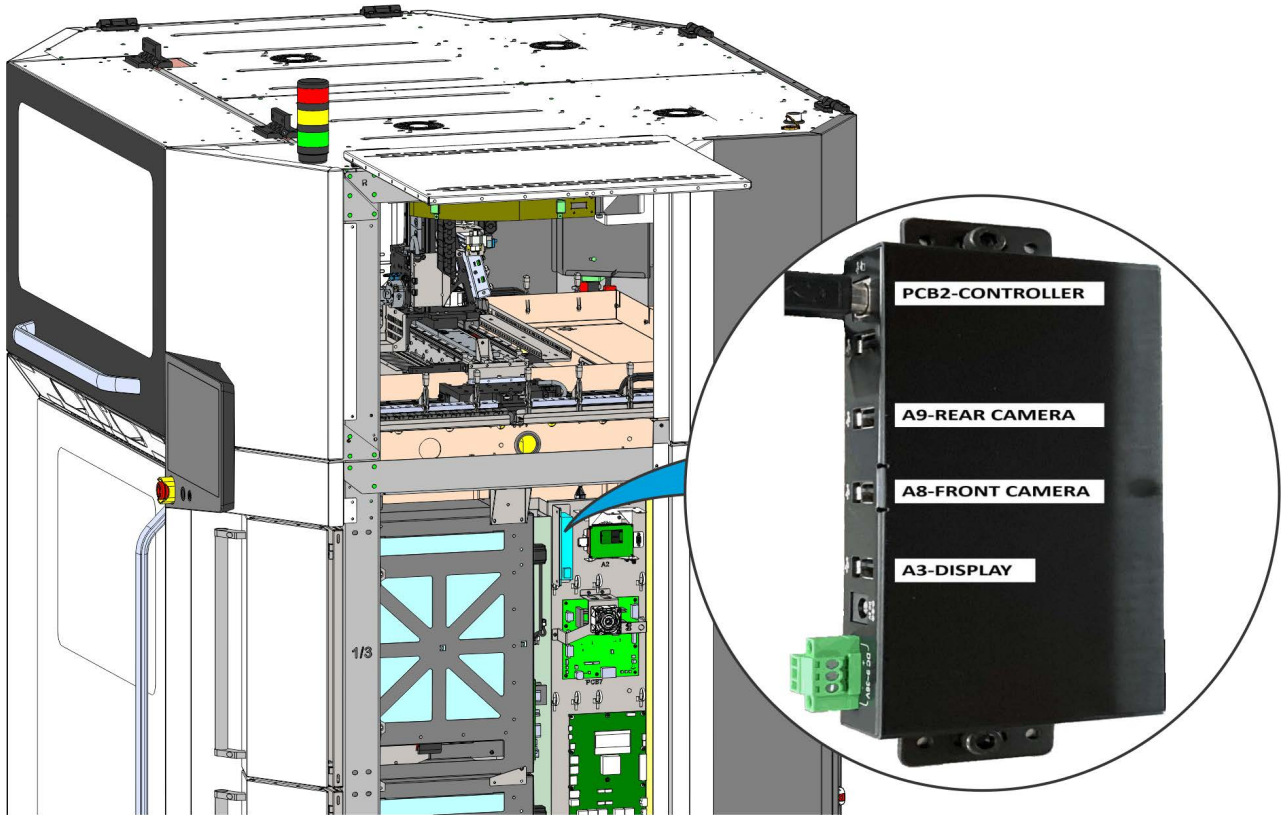
5. Remove and set aside the right side panel.



Move the side panel to a location where surface scratches can be prevented. Orient the panel to prevent bending or damage to the panel's mounting tabs.

6. Unplug the two camera USB cables from the USB Hub (A8,A9).

Figure 259: USB Hub



7. Reinstall the side panel. See [Figure 258](#).
8. Close the top service access door and use a # 2 Phillips screwdriver to tighten the captive screws (2) that secure the door. See [Figure 256](#).

8 Troubleshooting

This chapter describes troubleshooting steps that can be performed to correct basic problems with the F3300 printer.

Getting Help

If you have a problem with your printer or the printer's materials that is not covered in this guide, or if you need to order replacement parts, please contact Customer Support for your region. Contact information is available from the Stratasys website at:

<https://support.stratasys.com/en/Contact-Us>.

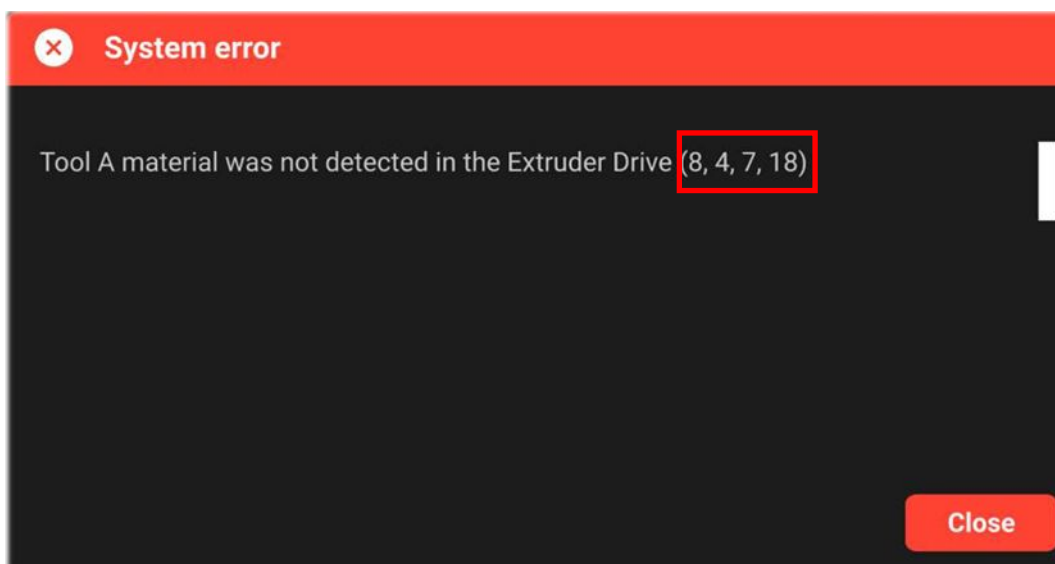
Before calling for service or supplies, always have the following information ready:

- Your printer's software version (see "Software Version" (page 191) for instructions on obtaining this information).
- Your printer's serial number (see Figure 60 (page 68)).
- Access to your GrabCAD Print workstation in order to provide a configuration file, if necessary (see "Exporting System Configuration (*.CFG) File" (page 208) for instructions on obtaining this information).

Warnings and Errors

The printer displays warnings and errors in dialog boxes as they occur. Controller software version 4.6 and above now include error code numbers at the end of the displayed message. These are important to help troubleshoot the error.

Figure 260: Error Code Numbers

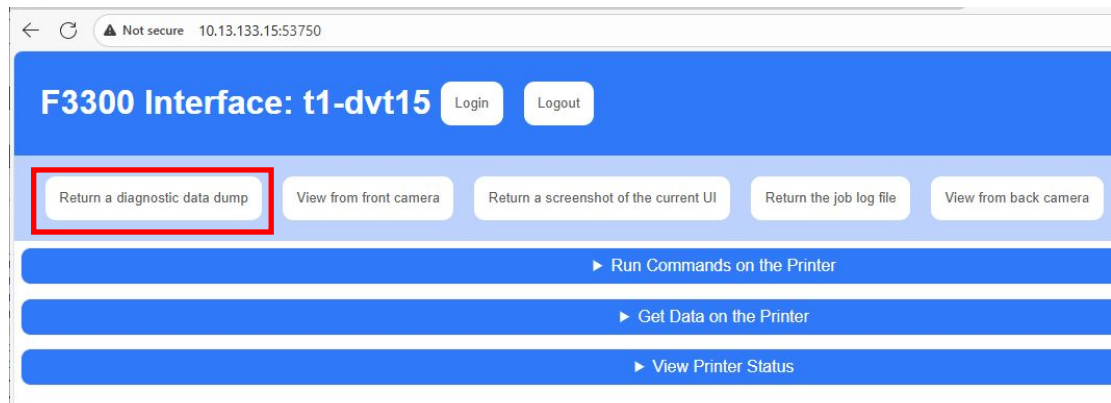


Obtaining a Diagnostic File

When an error occurs, the printer saves diagnostic files which can be used to determine the root cause of failures. To access the diagnostic file:

1. From an Edge or Chrome web browser, type in the printer's IP address followed by "":53750" (Example: 10.13.133.15:53750). Press **Enter**. The F3300 printer's web interface will display.
2. Select **Return a diagnostic data dump**. Send the downloaded file to your regional support center.

Figure 261: F3300 Web Interface



Errors Preventing a Build from Starting

Software process prepareSystemTask error

This error is generally seen after an initial bootup. Verify that the gantry is centered and that there isn't any binding in any axis.

Load/Unload Errors

Bay Motor Axis Error

A Bay Motor Axis Error can occur when the filament path friction is too high for the bay motor to drive filament to the extruder. Make sure that there are no kinks in the filament and the end of the filament is cleanly cut, not compressed or deformed beyond the filament profile diameter.

Build Pause Warnings



Any pause not initiated by the operator will display a warning which must be acknowledged on the User Interface before the printer can resume building.

Bay motor X is disabled

Perform jam recovery steps as described in [“Tool and Material Bay Jams” \(page 241\)](#).

Extruder motor X is disabled

Perform jam recovery steps as described in [“Tool and Material Bay Jams” \(page 241\)](#).

Tool X extruder motor jam

Perform jam recovery steps as described in [“Tool and Material Bay Jams” \(page 241\)](#).

User requested

- Indicates that a pause was initiated by the operator or inserted within the job’s file.
- Correct condition - resume the build by pressing the **Play** button within the Build page (see [Table 13 \(page 121\)](#) for button details).

Build Abort Errors



All abort related errors must be acknowledged on the User Interface before the printer is put into an aborted state.



The warnings and errors listed below are displayed within the notifications area of the Head Details page. See [“Viewing Hot End Details” \(page 130\)](#) for details.

Finding a Remedy

The following table lists various troubleshooting scenarios you may encounter when operating the printer and methods for resolving these scenarios.

Table 16: Troubleshooting by Symptoms

Symptoms	Solutions
UI Crashed	<ol style="list-style-type: none"> 1. If printing, wait for part to complete 2. Reboot system
Move Gantry: Gantry faulted Unable to prepare tool # for current swap SwapTool Failed	<ol style="list-style-type: none"> 1. Open hood 2. If tool is attached to gantry, release tool and return to appropriate dock 3. Reboot
Did not detect the presence of a tool in dock location. Unable to prepare tool # for Current swap. SwapTool failed	<ol style="list-style-type: none"> 1. Open hood 2. If tool is attached to gantry, release tool and return to appropriate dock 3. Reboot
Triggered ActiveMaterialPathD error test: Bay D disabled	Likely a tool jam. Perform jam recovery steps as described in "Tool and Material Bay Jams" (page 241)
Triggered Motion Warning test: "High Y Axis Yaw Current. Remap the Gantry"	<ul style="list-style-type: none"> • Indicates that the current draw between Y1 and Y2 is not even. • Verify that the leveling foot is properly set. See "Stabilizing the Printer" (page 66) . • Call your regional service center.
Triggered ActiveMaterialPath# error test: "Tool # FE Error".	Likely a tool jam. Perform jam recovery steps as described in "Tool and Material Bay Jams" (page 241)
Control Center reported printer as "Disconnected"	Reboot printer
Detected error in filament path: Following error limit exceeded on axis TCB_BayMotor#	Likely a tool jam. Perform jam recovery steps as described in "Tool and Material Bay Jams" (page 241)
Failed to load material into hot end	Same as above
Starting Preconditions Failed. Unknown Tool	<ol style="list-style-type: none"> 1. Open hood 2. If tool is attached to gantry, release tool and return to appropriate dock 3. Reboot
TCB_BayX_Spool: Spool cannot increase volume	Nuisance error – clear and proceed
TCB_BayX_Spool is not present	Disconnect/reconnect the spool handle.
TCB_BayX_Spool communication error	Disconnect/reconnect the spool handle.

Table 16: Troubleshooting by Symptoms (Continued)

Symptoms	Solutions
Detected error in filament path: Force threshold exceeded	Nuisance error – clear and proceed
Could Not Start Build. A build could not start for these reasons: -- BUT no reasons appear!	Nuisance error – clear and proceed
Timeout getting variant with packet ID	Nuisance error – clear and proceed
Feeder= Failed to process part	Attempt to resume building the part. If the build fails, abort and restart.
Gantry and or Z stage Disabled	<ol style="list-style-type: none"> 1. If the platen is at the build plane, go to the Settings menu and move the Z stage to middle of travel. 2. Open and close the Tool Hood or Door to re-enable the gantry/Z stage. 3. Attempt to resume building. 4. If resuming the build is unsuccessful, reboot printer. 5. If the issue recurs, call the regional support center.

Tool and Material Bay Jams

Perform the following steps to recover from material jams at the tool or inside material bays.

Procedure

1. From the Consumables page, select the jammed bay, extruder or hot end and select **Unplug**. If successful, proceed to build, otherwise continue to [step 2](#).
2. Inspect the filament spool for snags or tangles.
3. Press **Unload** and verify success (do not retract).
 - If successful proceed to [step 4](#).
 - If unsuccessful, skip to [step 5](#).
4. Press **Load**.
 - If successful, resume the build and exit this procedure.
 - If unsuccessful, proceed to [step 5](#).
5. Using the manual buttons (Extrude Forward/Extrude Reverse) on the tool base, back out the filament from the extruder drive (do not retract the filament). See “[Tool Base Buttons](#)” ([page 245](#)).
 - If successful, press **Load**. Verify the purge and resume build.
 - If unsuccessful, proceed to [step 6](#).



Reversing the filament too far can cause a loop to form at the spool. A filament loop can escape from the spool flange and jam the spool. It is best practice to check for loose filament wraps after using the tool base buttons.

6. Use the tool base cutter to cut the filament at the extruder (do not retract the filament). See “[Tool Base Cutter](#)” ([page 246](#)).
7. Using gloves, remove the hot end and extruder drive and disassemble them.
8. Remove any filament pieces from the extruder drive and hot end.
9. Reassemble the hot end and extruder drive.
10. Reinstall the extruder assembly to the tool base.
11. Load filament and verify purge.
12. Resume building.

Recovering from a Failed Build

Recovering from a Power Failure or Build Freeze

If a power failure or build freeze occurs, (power **OFF** first, if frozen) power **ON** the printer using the procedure described in [“Powering On the Printer” \(page 146\)](#).



The platen lowers before any gantry homing occurs, and the printer offloads the tool currently held on the gantry.

Recovering from a Loss of Shop Air

If shop air is lost suddenly during a build, the printer will pause and lower the platen. The tool will remain on the tool changer and will be offloaded during power-up. If this occurs, perform the following steps:

1. Power **OFF** the printer using the procedure described in [“Powering Off the Printer” \(page 149\)](#).
2. When shop air is restored, power **ON** the printer using the procedure described in [“Powering On the Printer” \(page 146\)](#).

Recovering from an E-stop Activation

If the E-stop is engaged during the course of a build, perform the following procedure:

1. Power **OFF** the printer using the procedure described in [“Powering Off the Printer” \(page 149\)](#).
2. Disengage the E-stop by rotating it clockwise.
3. Power **ON** the printer using the procedure described in [“Powering On the Printer” \(page 146\)](#).




The platen lowers before any gantry homing occurs, and the printer offloads the tool currently held on the gantry.

Tool Maintenance

Pressing the **Unplug** button in the **Consumables** menu performs a purge using parameters that help to unplug a hot end. If unsuccessful, the following tools will aid in recovering from a material feed jam or plug.

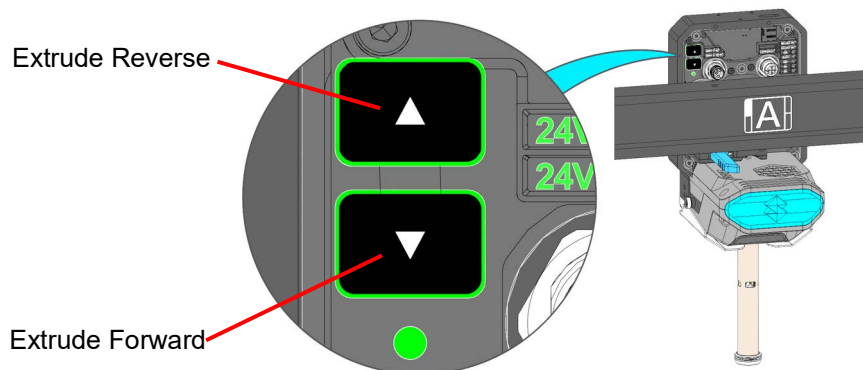
Tool Button Enable

Each tool base has manual Extrude Forward (down) and Extrude Reverse (up) buttons. These will aid in recovering from a hot end material feed jam. See [Figure 262](#).



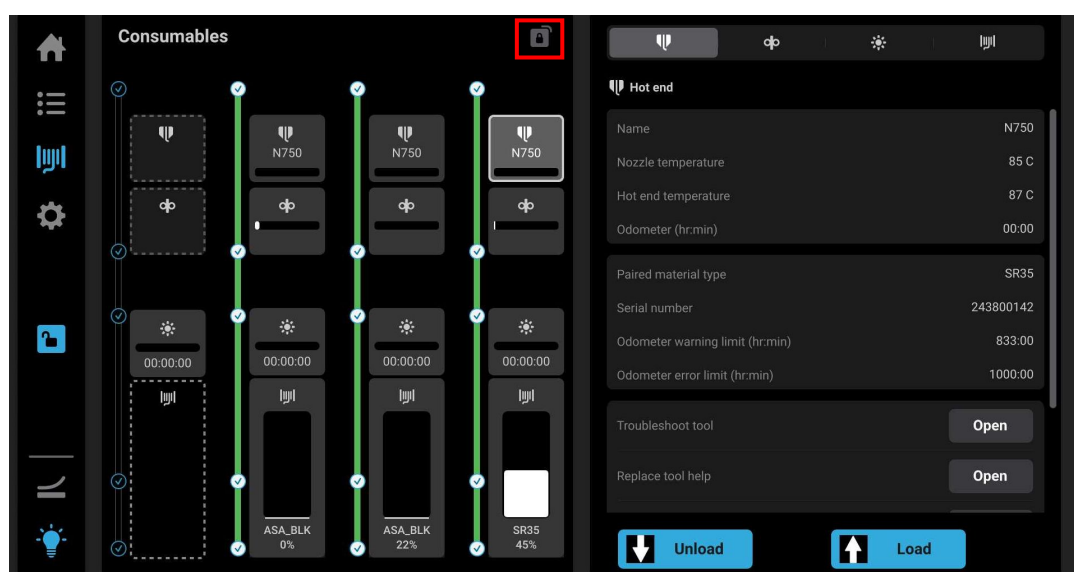
Reversing the filament too far can cause a loop to form at the spool. A filament loop can escape from the spool flange and jam the spool. It is best practice to check for loose filament wraps after using the tool base buttons.

Figure 262: Extrude Forward and Extrude Reverse buttons



1. To use the tool base buttons noted above, select the hood unlock icon. See [Figure 263](#). The default color of the hood unlock icon is gray. After selecting it, it will turn blue. This indicates the hood is unlocked.

Figure 263: Unlock hood

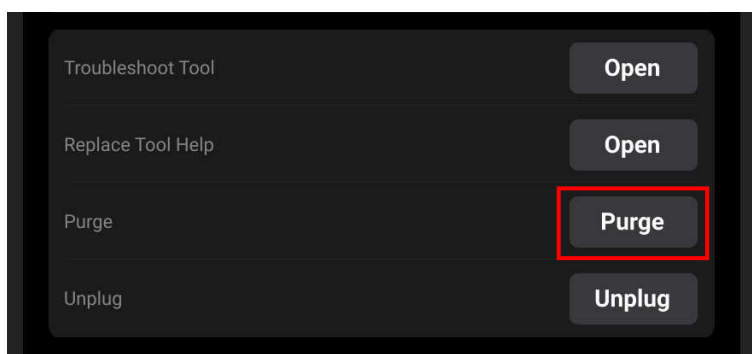


2. Open the hood.
3. To reach the buttons, use a step ladder. See [“Potential Safety Hazard Areas”](#) (page 61).
4. Pressing either the Extrude Forward (down) button or the Extrude Reverse (up) button will enable the selected hot end, and the hot end will begin heating. As the hot end heats, the buttons change color to indicate they are ready to use.
5. Press the Extrude Reverse button to unload the filament and retract it from the hot end and drive. While pressing the button, the material bay motor also retracts the filament into the material bay. Ensure the spool is properly wound after retracting material.

Purge

Pressing the **Purge** button instructs the printer to perform a long purge. After pressing this button, the extruder will heat to a predetermined set point temperature. Once the extruder reaches this set point, material will be purged from the tip for about 10 seconds. The Purge button is selectable (i.e. a Purge can be initiated) when the button is solid blue, and disabled (i.e. a Purge is in process or cannot be initiated) when gray. A notification badge will be displayed within the button if any preconditions exist preventing the purge from occurring.

Figure 264: Purge Button



Load /Unload

Depending on the load status of the selected tool, either the Load or Unload button will be displayed. Pressing the **Load** button instructs the printer to load material to the corresponding tool. Pressing the **Unload** button instructs the printer to unload material from the corresponding tool. A notification badge will be displayed within the button if any preconditions exist preventing the load/unload from occurring (see [“Load/Unload Errors”](#) (page 237)).

Figure 265: Load and Unload Buttons



Tool Base Buttons

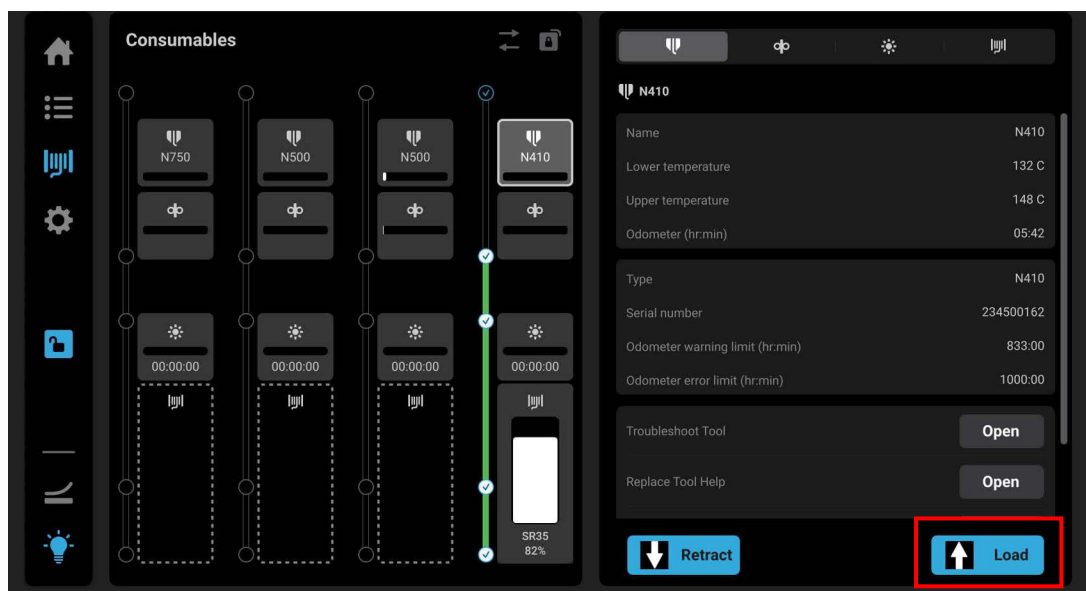
When material does not unload or purge, the manual tool base buttons (Extrude Forward/ Extrude Reverse) can help to either load or unload material from the extruder.



Reversing the filament too far can cause a loop to form at the spool. A filament loop can escape from the spool flange and jam the spool. It is best practice to check for loose filament wraps after using the tool base buttons.

1. Unlock the hood using the button on the Consumables tab.
2. Open the hood.
3. Press (approximately three seconds) and release one of the tool base buttons. The extruder assembly status light will flash green, indicating that the extruder is heating. After a minute, the status light will change to steady green, indicating that the extruder is ready.
4. To purge, press and hold the Extrude Forward (down arrow) button. Both the tool base and bay will drive material forward. The feed rate is slow (0.25in/sec), so it can take a while. You can open the bay door and watch the spool to verify motion.
5. To unload or retract, press and hold the Extrude Reverse (up arrow) button. Both the tool base and bay will drive material backwards. The feed rate is slow (0.25in/sec), so it can take a while. You can open the bay door and watch the spool filament to verify motion.
6. To exit tool maintenance, do not press any buttons for 30 seconds. The extruder assembly status light will go off.
7. Close the hood.
8. Upon using tool base buttons, the hot end is marked as unloaded.
9. If desired, press the LOAD button in the Consumables menu screen to return the hot end position to “In Liquefier”.

Figure 266: Consumables Menu



Tool Base Cutter

If you are unsuccessful using the manual tool base buttons to unload and clear a filament jam, use the tool base cutter to cut and remove the filament.

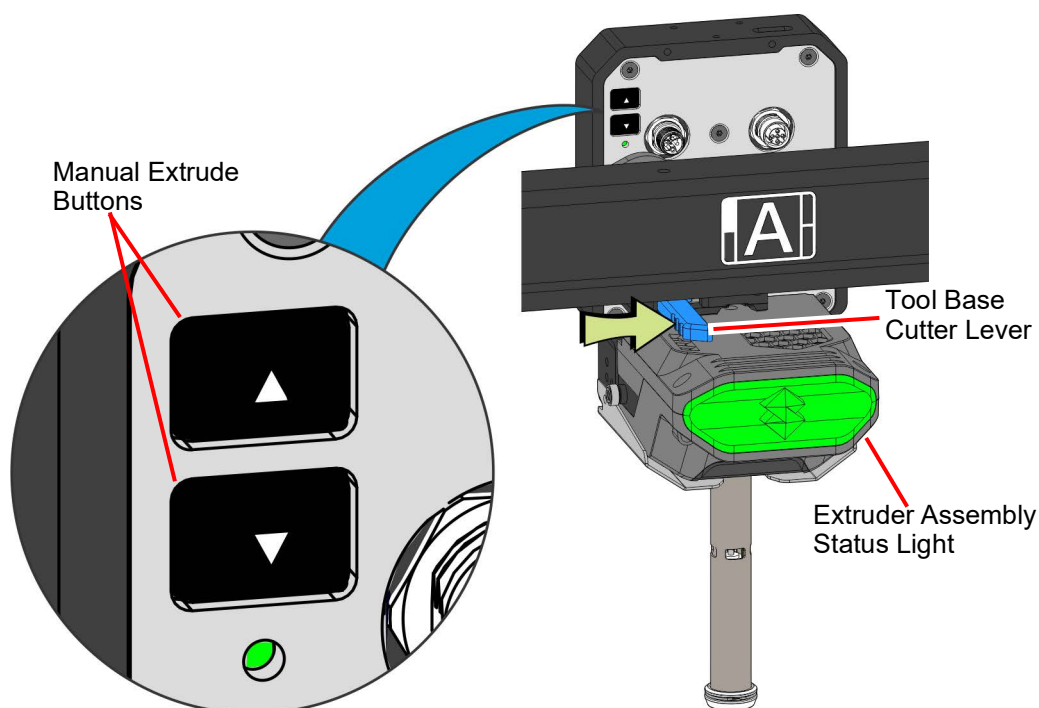


Warning: Hot Surface

Always wear safety gloves when handling the hot end or extruder.

1. Push the tool base cutter lever to the right. See [Figure 267](#).
2. Press (approximately three seconds) and release one of the manual extrude buttons on the tool base to heat up the extruder. The extruder assembly status light will pulse green while heating and hold steady green when it reaches temperature.

Figure 267: Extruder and Tool Base Detail



3. Wait 30 seconds for the green status light to turn off, indicating power is removed from the extruder.
4. Remove the extruder assembly from the tool base.
5. Using a glove to hold the hot end, remove the hot end from the extruder assembly.
6. While holding the hot end with the glove, pull the filament from the hot end.



To prevent the hot end from plugging, remove the filament from the hot end while it is still hot.

MTConnect

MTConnect is a communications standard implemented on the F3300. The standard uses a well defined data model that is presented in XML format over HTTP. There are 57x data streams available from the F3300 with additional streams expected to be added. The MTConnect data streams can be used to view process information. Customers can use an MTConnect client of their choice to view and log printer data. For more information regarding MTConnect, visit www.mtconnect.org.

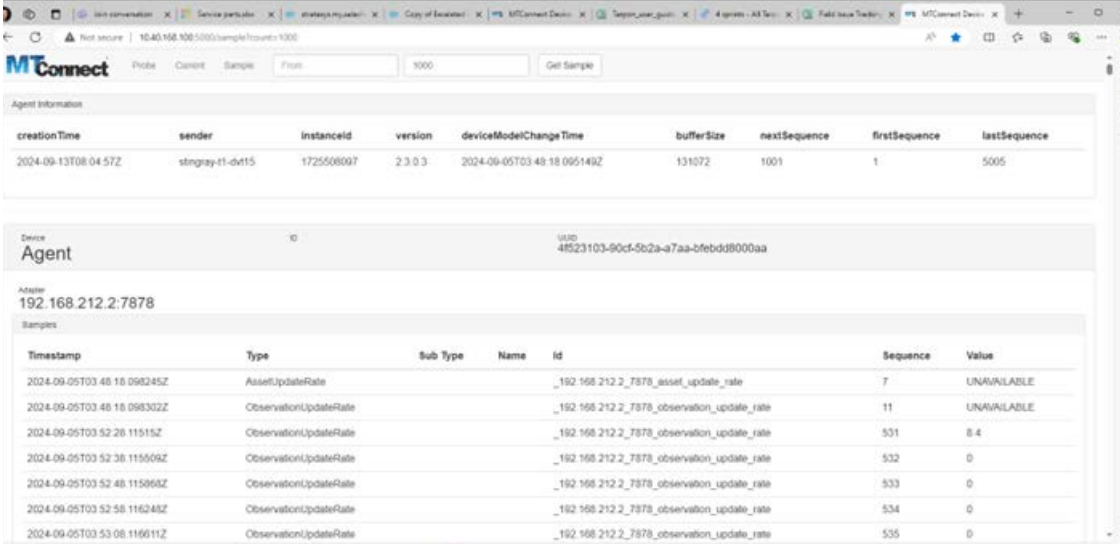
To verify that MTConnect data is being streamed, from a standard Internet browser, such as Chrome, type in the IP address followed by “:5000/sample?count=1000”. Then press **Enter**.

Example:

```
http://10.40.168.100:5000/sample?count=1000
```

If no data is retrieved, make sure MTConnect is turned **ON** within the printer settings.

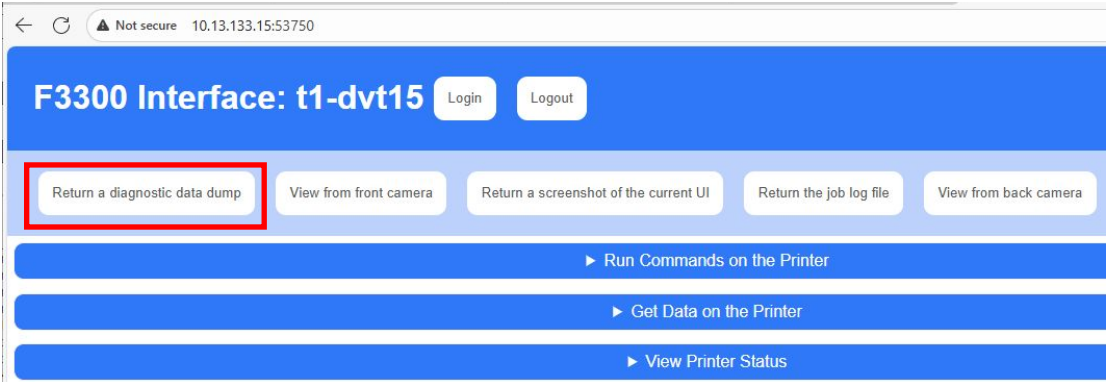
Figure 268: Viewing MTConnect Data with a Web Browser



To obtain a list of the MTConnect data available:

1. From an Edge or Chrome web browser, type in the printer's IP address followed by “:53750” (Example: 10.13.133.15:53750). Press **Enter**. The F3300 printer's web interface will display.

Figure 269: F3300 Web Interface



2. Select **Get Data on the Printer** and then select **Return the device schema file used to display MTConnect data option**. An html file listing the available data streams will be downloaded.

Figure 270: F3300 Web Interface



9 Regulatory and Environmental Information

Declaration of Conformity

Declaration of Conformity information is available from your Stratasys representative. Please contact your local regional office for a copy of this document.

Electromagnetic Compatibility (EMC)

EMC Class A Warning



Warning: Electromagnetic Interference

This is a Class A product. In a domestic environment this product may cause radio interference in which case the user may be required to take adequate measures.

FCC Class A Statement (U.S.A.)

This equipment has been tested and found to comply with the limits for a Class A digital device, pursuant to Part 15 of the FCC Rules. These limits are designed to provide reasonable protection against harmful interference in a commercial environment. This equipment generates, uses and can radiate radio frequency energy and, if not installed and used in accordance with the instructions, may cause harmful interference to radio communications. Operation of this equipment in a residential area is likely to cause harmful interference, in which case the user will be required to correct the interference at their own expense.

FCC Suppliers Declaration of Conformity:

47 CFR 2.1077 Compliance Information

Unique Identifier: F3300


Responsible Party - US Contact Information:

Contact information for the responsible party in the US is available on the Stratasys Support Center website at: <https://support.stratasys.com/en/contact-us>.

FCC Compliance Statement:

The U.S. Federal Communications Commission (in 47 CFR 15.105) has specified that the following notices be brought to the attention of users of this product.

This device complies with part 15 of the FCC rules. Operation is subject to the following two conditions: (1) this device may not cause harmful interference, and (2) this device must accept any interference received, including interference that may cause undesired operation.

	<p>Caution: Pursuant to Part 15.21 of the FCC Rules, any changes or modifications to this equipment not expressly approved by Stratasys, Ltd. may cause harmful interference and void the FCC authorization to operate this equipment.</p>
---	---

Canada Electromagnetic Compatibility (EMC)

Normes de Sécurité (Canada)

Le présent appareil numérique n'émet pas de bruits radioélectriques dépassant les limites applicables aux appareils numériques de Classe A prescrites dans le règlement sur le brouillage radioélectrique édicté par le Ministère des Communications du Canada.

DOC Statement (Canada)

This digital apparatus does not exceed the Class A limits for radio noise emissions from digital apparatus set out in the Radio Interference Regulations of the Canadian Department of Communications.

Material Safety Data Sheets (MSDS)

You can obtain current Material Safety Data Sheets for printer materials from the Stratasys Support Center website at: <https://support.stratasys.com/en/materials/sds>.

Waste Electrical and Electronic Equipment Directive (WEEE) Symbol



In the European Union (EU), this symbol indicates that when the last user wishes to discard a product, it must be sent to appropriate facilities for recovery and recycling. For information about proper disposal, check your purchase contract, or contact the supplier of the equipment.

UK Conformity Assessed (UKCA) Marking



This conformity mark indicates that the printer conforms with the applicable requirements for products sold within Great Britain.

Conformité Européenne (CE) Marking



This conformity mark indicates that the printer conforms with European Union's safety, health, and environmental protection requirements.

GrabCAD and GDPR

GrabCAD complies with the European Union's General Data Privacy Regulation. For any questions, contact support@grabcad.com.

Appendix A: Diagrams and Schematics

Figure 271: F3300 AC ladder diagram (sheet 1 of 3)

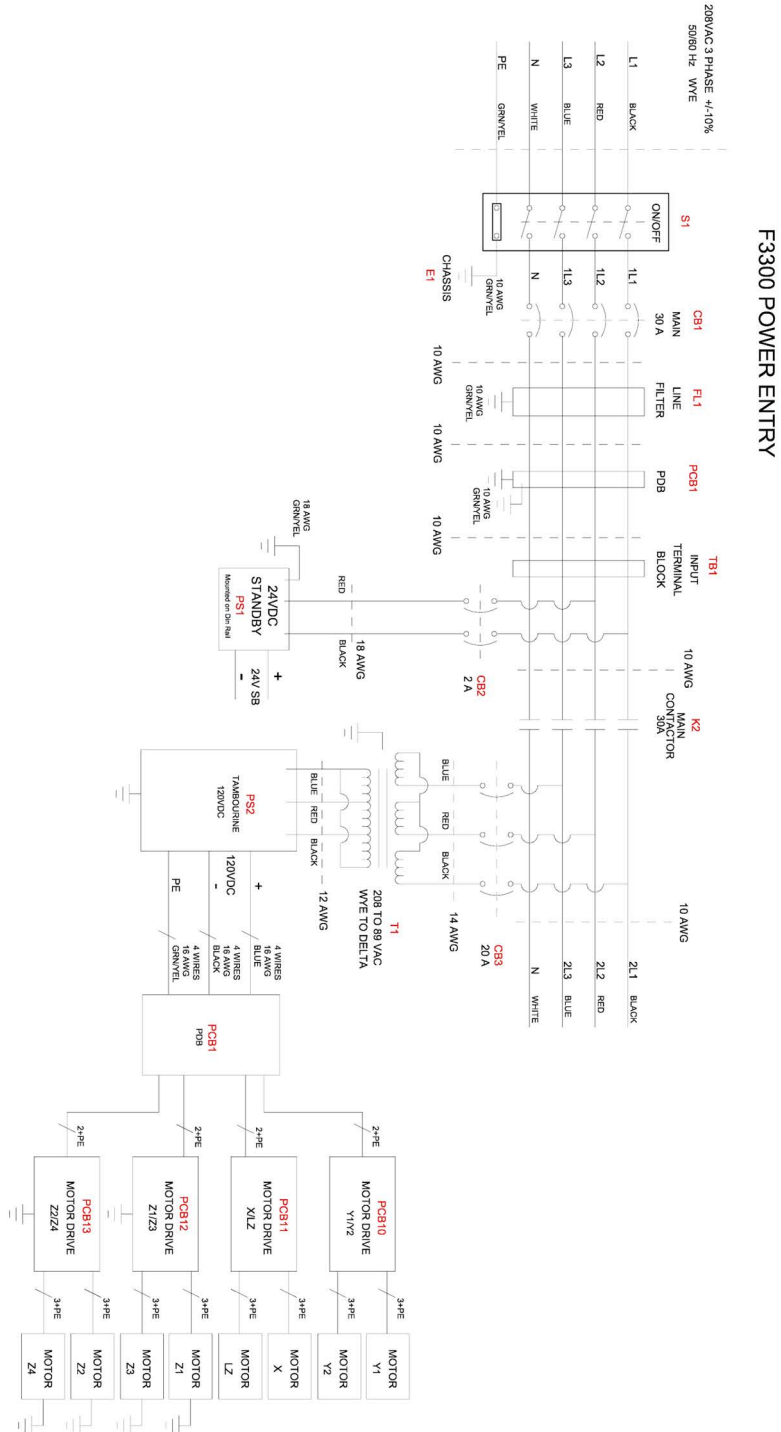


Figure 272: F3300 AC ladder diagram (sheet 2 of 3)

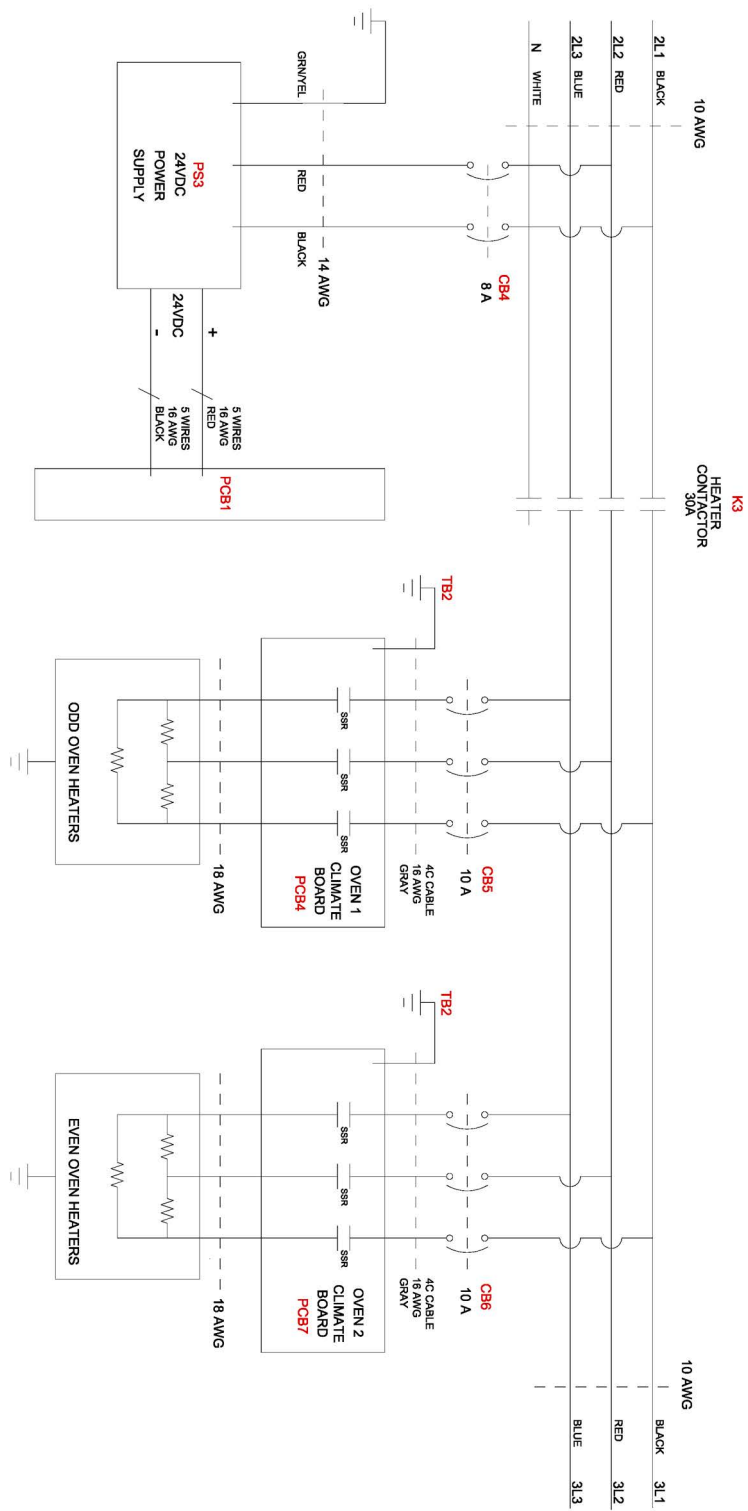


Figure 273: F3300 AC ladder diagram (sheet 3of 3)

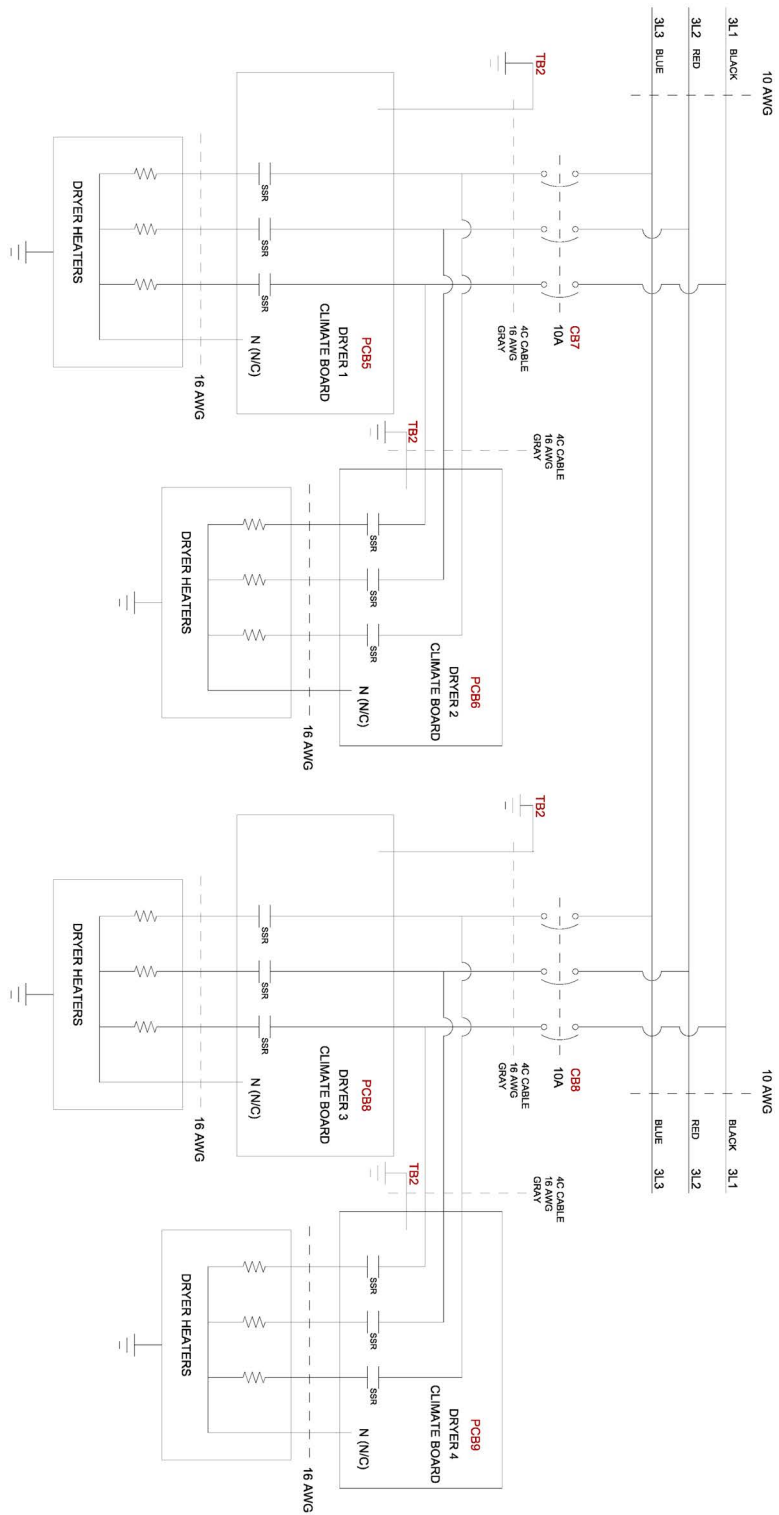
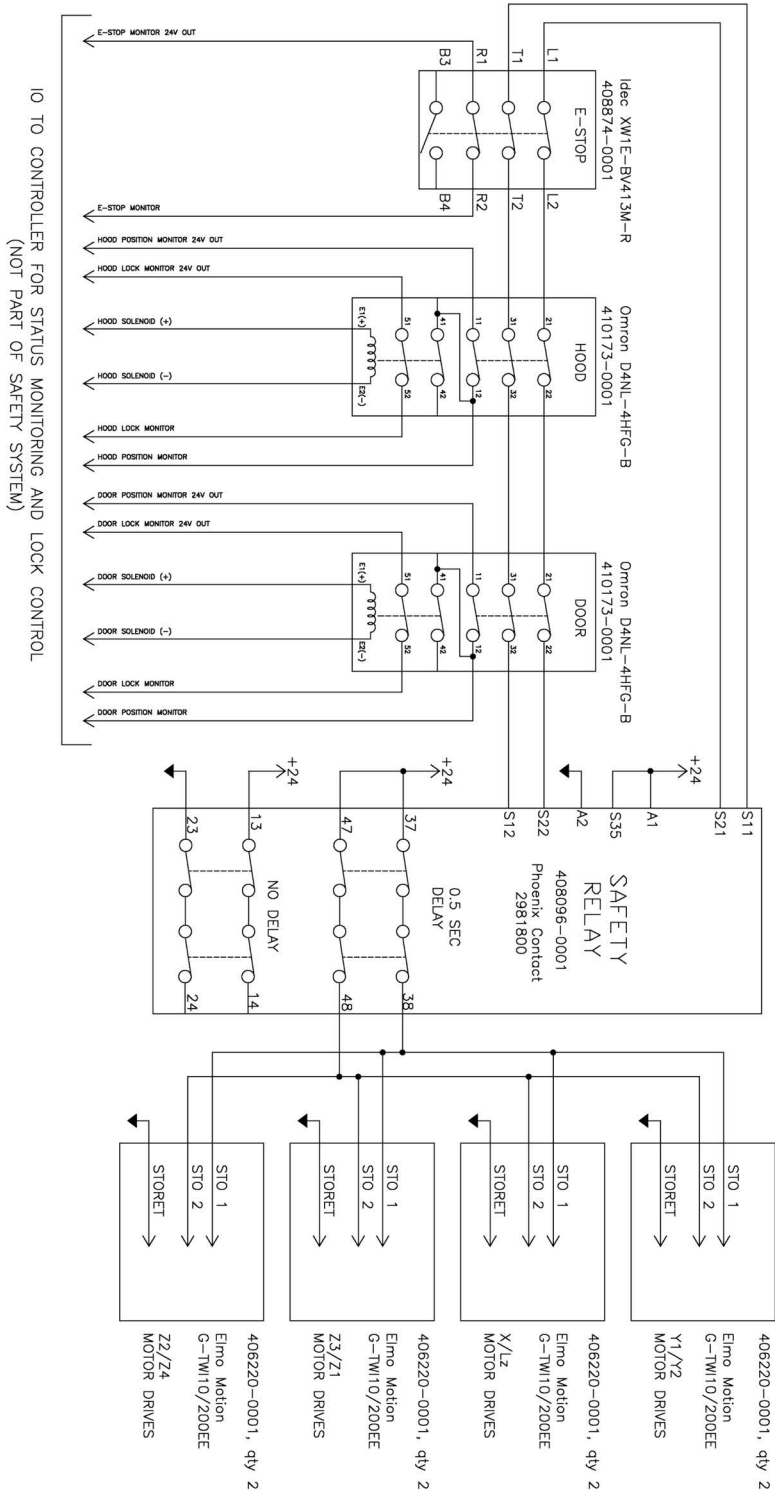


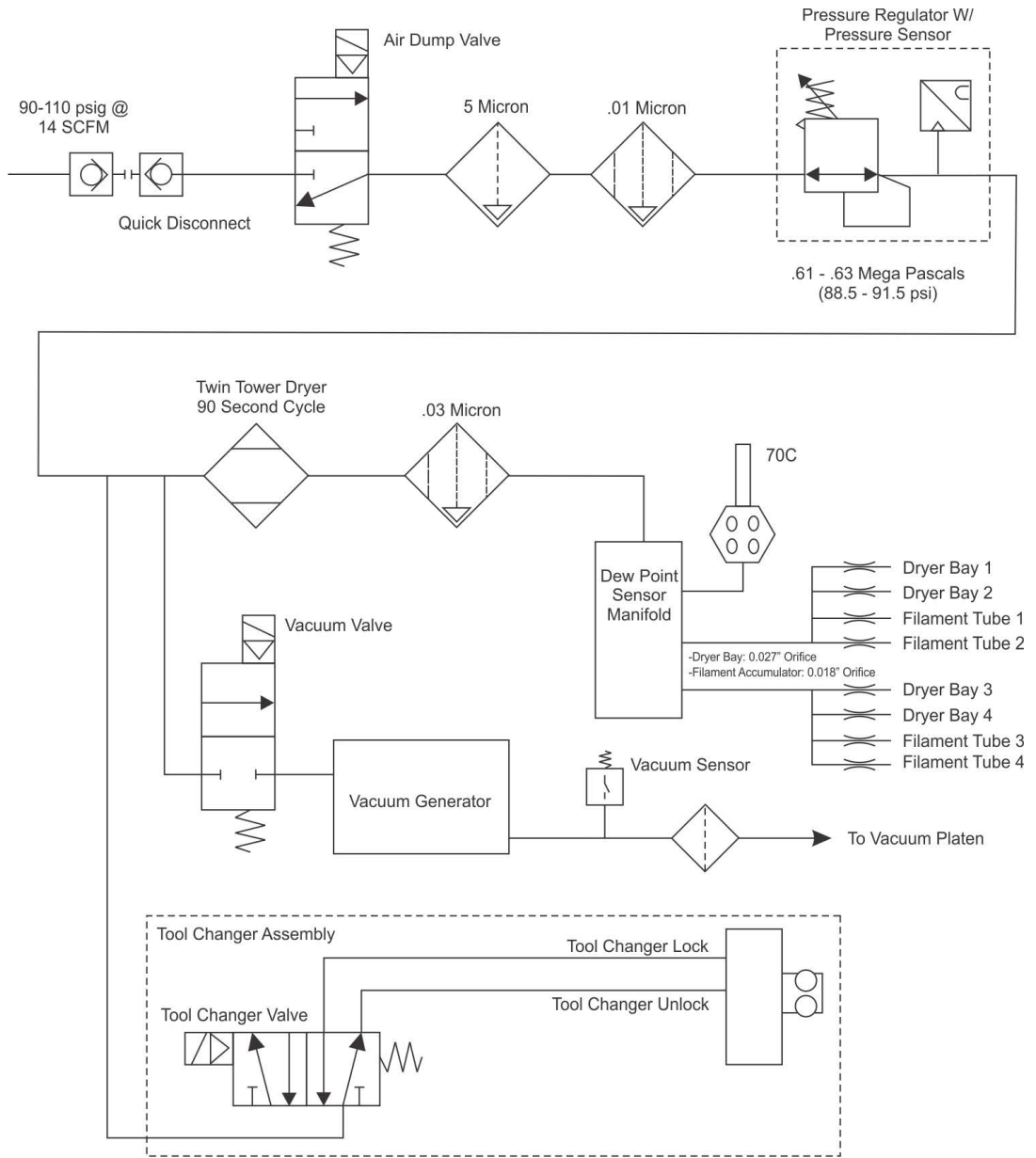
Figure 274: Safety circuit diagram



* STATE SHOWN WHEN DOORS ARE LOCKED AND CLOSED (SAFETY RELAY ACTIVE)

IO TO CONTROLLER FOR STATUS MONITORING AND LOCK CONTROL
(NOT PART OF SAFETY SYSTEM)

Figure 275: Pneumatics circuit diagram



www.stratasy.com

c-support@stratasy.com
Copyright © 2024-2026 Stratasy Ltd. All rights reserved.
Part No. 413862-0001_REV_E

