



stratasys

Fortus[®] 250mc

3D Production System

USER GUIDE

LIABILITY STATEMENT

The information in this document is subject to change without notice. Stratasys, Inc. shall not be liable for errors contained herein or for incidental or consequential damages in connection with the furnishing, performance, or use of this material. Stratasys, Inc. makes no warranty of any kind with regard to this material, including, but not limited to, the implied warranties of merchantability and fitness for a particular purpose. It is the responsibility of the system owner/ material buyer to determine that the Stratasys material is safe, lawful, and technically suitable for the intended application as well as identify the proper disposal (or recycling) method consistent with local environmental regulations. Except as provided in Stratasys' standard conditions of sale, Stratasys shall not be responsible for any loss resulting from any use of its products described herein.

COPYRIGHT STATEMENT

This document is protected by copyright. All rights reserved. Its use, disclosure, and possession are restricted by an agreement with Stratasys per software copyright. No part of this document may be photocopied, reproduced or translated into another language without the prior written consent of Stratasys, Inc.

All drawings and information herein are the property of Stratasys Inc. All unauthorized use and reproduction is prohibited.

TRADEMARK ACKNOWLEDGMENTS

Stratasys, FORTUS (Fortus) and FDM are registered trademarks of Stratasys, Inc.

FORTUS 250mc, Insight, Control Center, FDM Technology, Fused Deposition Modeling, Smart Supports, SR-30, and Finishing Touch are trademarks of Stratasys, Inc.

ULTEM™ is a registered trademark of SABIC or its affiliates or subsidiaries.

All other product names and trademarks are the property of their respective owners, and Stratasys assumes no responsibility with regard to the selection, performance, or use of these non-Stratasys products. Product specifications subject to change without notice.

TABLE OF CONTENTS

1 INTRODUCTION	1
HOW TO USE THIS MANUAL	1
LEARN MORE	1
RECYCLING	1
SAFETY PRECAUTIONS	2
2 OVERVIEW	4
3 SETUP	9
UNPACKING	9
Unpack the system	9
Installing Forklift Access Covers	11
NETWORKING THE SYSTEM	12
Connecting through a network	12
Connecting directly to a workstation	13
POWER CONNECTIONS	14
POWERING ON	15
INSTALLING SOFTWARE	16
Installing Insight and Control Center	16
Installing system software to the workstation	16
ESTABLISHING NETWORK COMMUNICATION WITH THE SYSTEM	17
Establishing communication on a dynamic network	17
Establishing communication on a static network	18
INSTALLING SYSTEM SOFTWARE ON SYSTEM	20
INSERT MODELING BASE	21

4 OPERATION 22

DISPLAY PANEL AND KEYPAD	22
SYSTEM SOFTWARE OVERVIEW	23
CONTROL CENTER OVERVIEW	24
PROCESSING YOUR STL FILE FOR PRINTING	25
Opening your STL file with Insight	25
Selecting layer resolution	25
Selecting model interior fill style	25
Selecting support style	26
Selecting the scale of your STL file	26
Selecting the orientation of your STL file	27
Selecting the visible surface style of your STL file	27
Processing your STL file	28
Printing your CMB file	28
Adding your CMB file to the pack	28
Opening your CMB file with Control Center	28
INSERTING A MODELING BASE	28
BUILDING A PART	29
Starting a build from a remote location	29
Starting a build from the display panel	29
LOADING MATERIAL	30
Load material cartridges	30
UNLOADING MATERIAL	32
Unload material cartridges	32
BUILDING A TEST PART	33
Build a test part	33
THE DISPLAY PANEL DURING BUILD	33
CHAMBER LIGHTS	33
PAUSING BUILD	34
RESUMING BUILD FROM PAUSE MODE	34
RESUMING OPERATIONS FROM STANDBY MODE	34
Continue operation from Standby mode	34
CANCELING A JOB	35
Cancel a job	35

AUTO POWER DOWN	35
Canceling auto power down	35
POWERING OFF	35
REMOVING A COMPLETED PART	36
Remove a completed part	36
Remove a completed part from the modeling base	36
REMOVING SUPPORT MATERIAL	36
Soluble Supports	36
5 MAINTENANCE	37
UPDATING CONTROLLER SOFTWARE	37
Web Method (preferred method)	37
CD Method (alternate method)	38
PLACING SYSTEM IN RECEIVE SOFTWARE UPGRADE MODE	38
STARTUP KIT TOOLS	38
PREVENTIVE MAINTENANCE	39
Daily	39
500 HOUR MAINTENANCE	41
Clean Fan Filter	41
Replace the tip wipe assembly	42
Tip shield replacement	43
2000 HOUR MAINTENANCE	46
Liquefier Tip Replacement	46
AS NEEDED MAINTENANCE	52
Chamber Light Bar	52
Replace chamber light bar	52
6 TROUBLESHOOTING	53
TROUBLESHOOTING CHECKLIST	53
FAULT DETERMINATION CODES	54
EXPORTING SYSTEM CONFIGURATION (.CFG) FILE	54
Exporting configuration file from the system	54

CYCLING POWER.....	55
DIAGNOSING LOSS OF EXTRUSION.....	55
CLOGGED TIP.....	56
MATERIAL JAM.....	57
RECOVERING FROM LOSS OF EXTRUSION.....	59
7 SUPPORT.....	64
CUSTOMER SUPPORT.....	64
8 RECYCLING.....	65
RECYCLING CODES.....	65
9 PRINTER SPECIFICATIONS.....	66
PHYSICAL SPECIFICATIONS.....	66
FACILITY SPECIFICATIONS.....	66
WORKSTATION SPECIFICATIONS.....	66
POWER SPECIFICATIONS.....	66
ENVIRONMENTAL SPECIFICATIONS.....	66
10 SUPPLEMENTAL INFORMATION.....	67
UNINTERRUPTIBLE POWER SUPPLY (UPS).....	67
Use and Installation.....	67
General Information.....	67
Parts List – Cable, UPS to Fortus system.....	68
DECLARATION OF CONFORMITY.....	70
REGULATORY AND ENVIRONMENTAL INFORMATION.....	70
EMC Class A Warning.....	70
FCC Statements (U.S.A.).....	70
Canada Electromagnetic compatibility (EMC).....	71
MSDS (Material Safety Data Sheet).....	71
Disposal of waste equipment by users in private households in the European Union.....	71

1 INTRODUCTION

The Fortus 250mc system is designed with ultimate simplicity in mind. The system enables you to build parts quickly, even if you have never used a Fortus system before.

The system models with ABS*plus*™ plastic, so modeled parts are strong and durable. ABS*plus* also ensures that you will be able to drill, tap, sand, and paint your creations. With the speed and convenience of Soluble Support Technology, completed parts are quickly available for review and test.

The Fortus 250mc system is an innovative combination of proprietary hardware, software, and material technology.

HOW TO USE THIS MANUAL

This User's Guide is laid out in easy to follow sections which cover Set-up, Operation, Maintenance, and Troubleshooting. Be sure to read each section carefully so that you will get the best performance from your system.

Throughout this User Guide, text representing **Interface Messages** that appear on the display panel are presented in a bold font.

LEARN MORE

An electronic User Guide is available on the User Guide CD. This guide provides information on the following topics:

- Troubleshooting information
- Important safety notices and regulatory information
- Detailed user instructions

You can also find more information at: <http://www.fortus.com>.

RECYCLING

Visit <http://www.stratasys.com/recycle> for recycling information.

SAFETY PRECAUTIONS

The following precautions ensure the proper use of the system and prevent the system from being damaged. Follow these precautions at all times.

- Ensure the system will be installed on a stable flat surface capable of holding 159 kg (350 lbs).
- Use the power supply voltage specified on the nameplate. Avoid overloading the system's electrical outlet with multiple devices.
- Ensure the system is well-grounded. Failure to ground the system may result in electrical shock, fire and susceptibility to electromagnetic interference.
- Before disassembling or repairing the system yourself, contact your local Service Representative. See Support section of User Guide.
- Use only the power cord supplied with the system. Do not damage, cut or repair the power cord. A damaged power cord has risk of fire and electric shock. Replace a damaged power cord with an approved power cord.
- Do not allow metal or liquids to touch the internal parts of the system. Doing so may cause damage, fire, electric shock or other serious hazards.
- Power off the system and disconnect the power cord from the power outlet in any of the following cases:
 - If there is smoke or an unusual smell coming from the system.
 - If the system is making an unusual noise not heard during normal operation.
 - A piece of metal or a liquid touches the internal parts of the system.
 - During an electrical (thunder/lightning) storm
 - During a power failure

The following classifications are used throughout this guide.



Caution: Indicates a potentially hazardous situation which, if not avoided, may result in minor or moderate injury.



Warning: Indicates a potentially hazardous situation which, if not avoided, could result in serious injury.



Hot Surface: The hot surface sign indicates the presence of devices with high temperatures. Always use extra care, and wear safety gloves, when working around heated components



Gloves: When performing some maintenance procedures, the machine may be hot and gloves will be required to avoid burns.



Safety Glasses: Wear safety glasses to avoid injury to your eyes.



Recycle: Use proper recycling techniques for materials and packaging.



**ESD
Sensitive!**

ESD: Use standard electrostatic discharge (ESD) precautions when working on or near electrical components.

2 OVERVIEW

The Fortus 250mc system builds models, including internal features, from CAD STL files. Three-dimensional parts are built by extruding a bead of ABS plastic through a computer-controlled extrusion head, producing high quality parts that are ready to use immediately after completion. With three layer resolution settings, you can choose to build a part quickly for design verification, or you can choose a finer setting for higher quality surface detail.

The Fortus 250mc system consists of two primary components — the Fortus 250mc system and Insight. Insight is the preprocessing software that runs on a Windows Vista or Windows 7 platform.

The build envelope measures 254 x 254 x 305 mm (10 x 10 x 12 in). Each material cartridge contains 922 cc (56.3 cu. in.) of usable material.

Figure 2-1: Front view

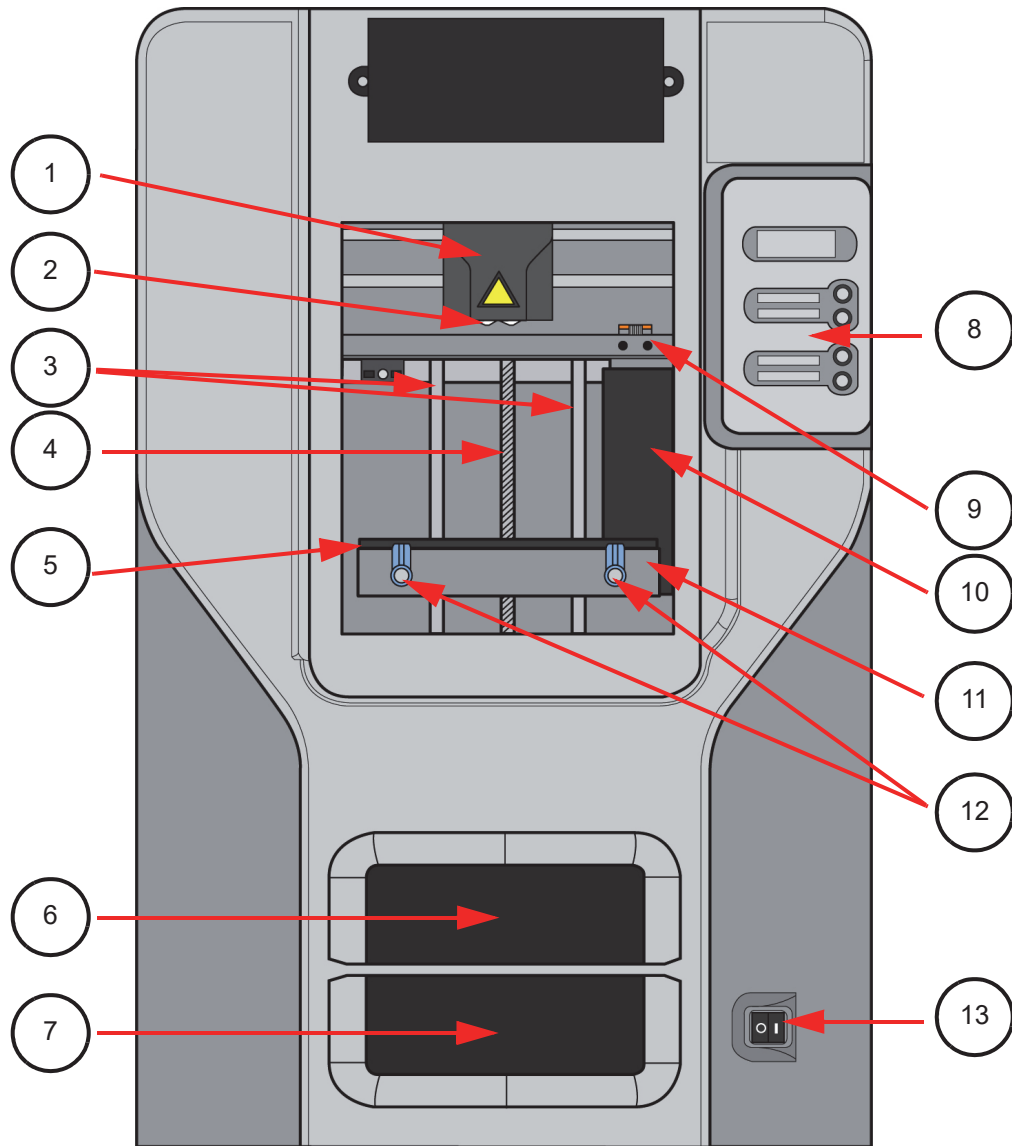

1	Extrusion Head	8	Display Panel
2	Extrusion Tips	9	Tip Cleaning Assembly
3	Guide Rods	10	Purge Container
4	Lead Screw	11	Z stage platen
5	Modeling Base	12	Modeling Base Retainers (2)
6	Model Material Cartridge	13	Power Switch
7	Support Material Cartridge		

Figure 2-2: Rear view

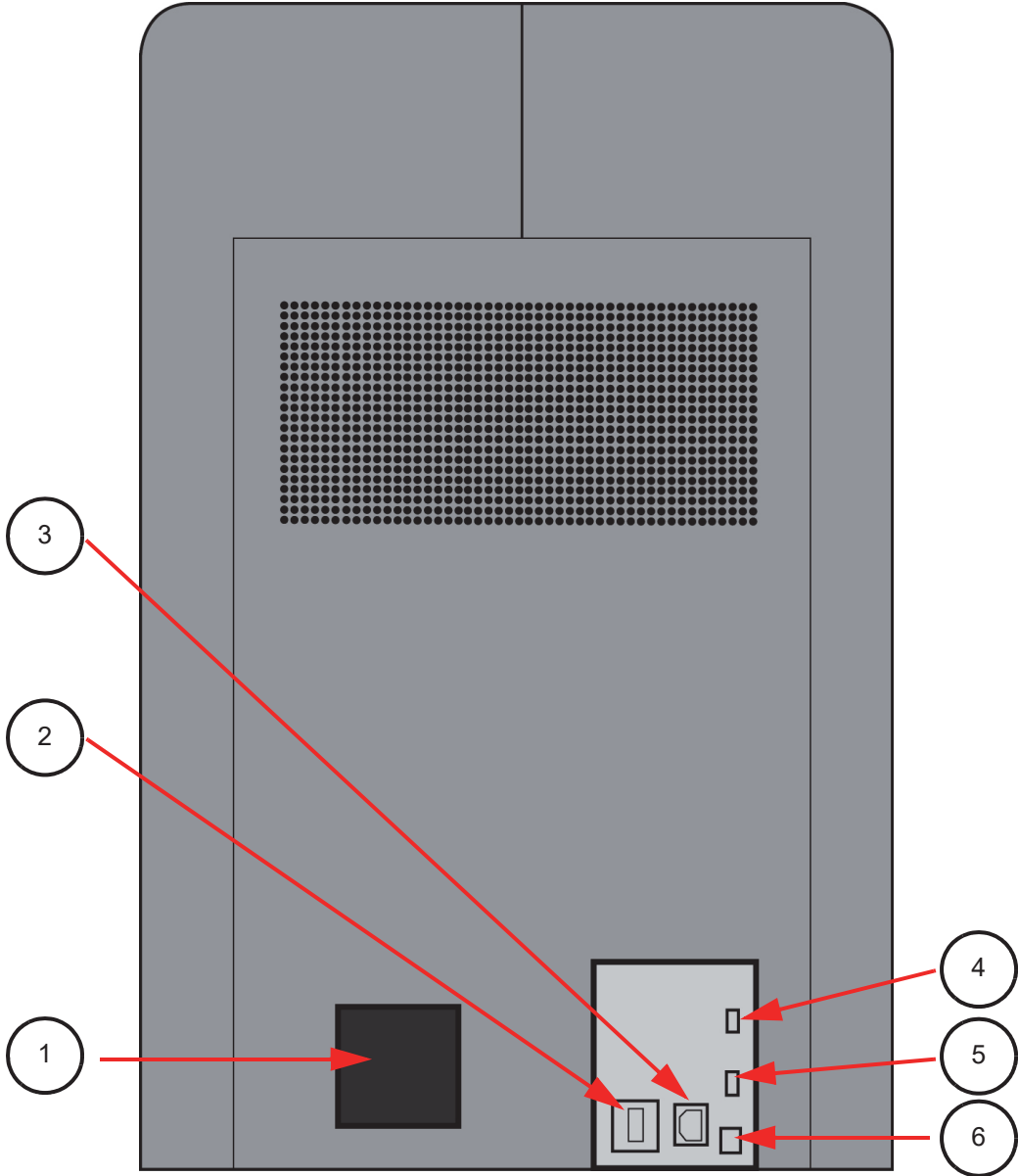

1	Fan Cover	4	UPS Connection
2	Main Circuit Breaker	5	Diagnostic Hookup
3	Power Cord Adapter	6	Network Cable Connection

Figure 2-3: Material cartridge

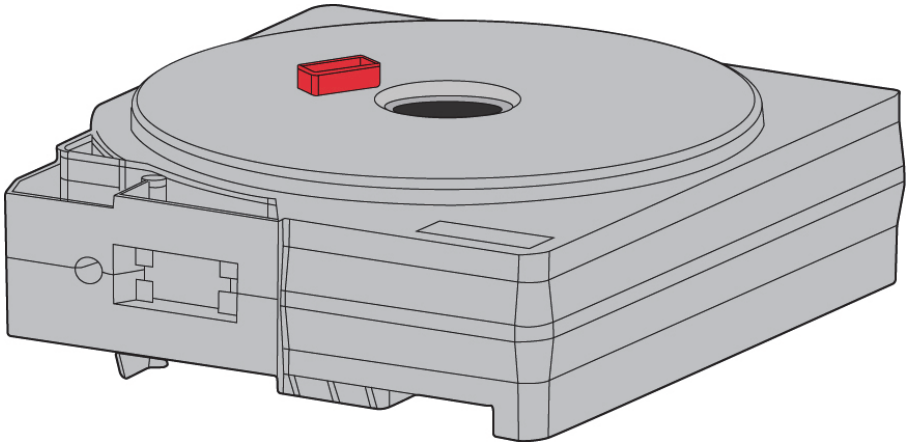
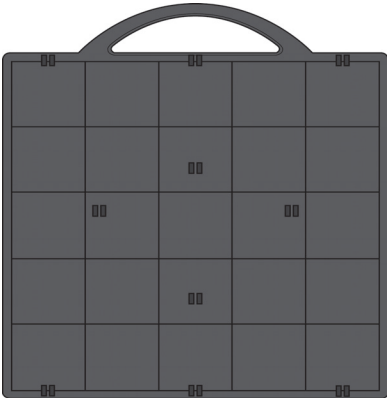

Figure 2-4: Modeling base



Modeling base



Caution: DO NOT reuse modeling bases. If a modeling base is reused, calibration errors, poor part quality, and loss of extrusion may occur. Additional modeling bases are available from your reseller.

Figure 2-5: Startup Supplies

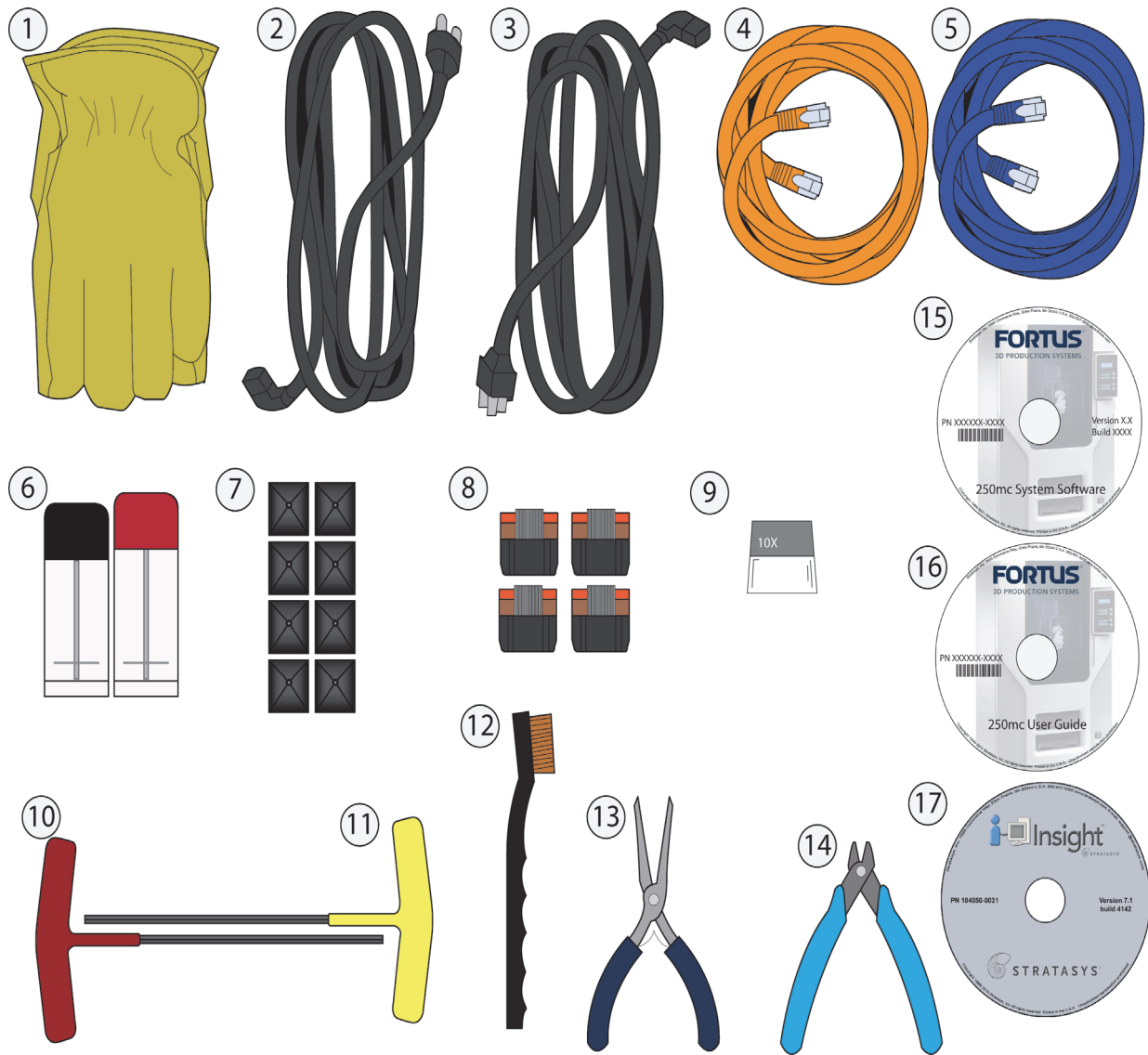

1	Insulated Leather Gloves (Pair)	10	$\frac{1}{8}$ " T-Handle Allen wrench (red)
2	Power Cord (Europe)	11	$\frac{7}{64}$ " T-Handle Allen wrench (yellow)
3	Power Cord (U.S.)	12	Bronze Brush
4	Crossover Cable (Orange)	13	Needle Nose Pliers
5	Network Cable (Blue)	14	Cutters
6	Model and support tips	15	Fortus 250mc System Software CD
7	Tip shield (8)	16	Fortus 250mc User Guide CD
8	Tip Wipe assembly (4)	17	Insight CD
9	10x Magnifier Loupe	18	P430 Model Material Cartridge (1)
		19	SR-30 Soluble Support Material Cartridge (1)

3 SETUP

UNPACKING

This section describes the recommended procedures for unpacking and preparing the system for its first use.

UNPACK THE SYSTEM



Warning: The system weighs approximately 148 kg (326 lbs). Use proper moving and lifting techniques when positioning the unit. For your convenience, there are forklift pads built into the bottom of the unit. They are accessible from the side of the unit.

1. Before unpacking the system, move it near to its operating location.
2. Remove the plastic banding from around the cardboard.
3. Remove the top cover. Set aside the fork access covers (2) and bag of screws (2).
4. Remove screws (4) that attach cardboard to pallet and remove the cardboard side panels.
5. Remove the top foam.
6. Remove outer plastic wrap - use care if using a knife so as to not scratch the system.
7. Remove the foam door channels (2) and tape.



Warning: The Lead Screw and Guide Rods are lubricated with a thin coat of Krytox grease. Krytox grease can cause skin irritation. Be careful not to get the grease on your hands or clothing.



Caution: Remove the foam tubes that isolate the extrusion head from the frame, see [Figure 3-1](#). The system will be damaged if powered on with the foam tubes in place.



Caution: Be careful not to damage the rod sensors when removing the foam tubes, see [Figure 3-1](#).

8. Remove the foam tubes that isolate the extrusion head from the frame, see [Figure 3-1](#).

Figure 3-1: Foam tubes isolating the extrusion head from the XY-axis frame

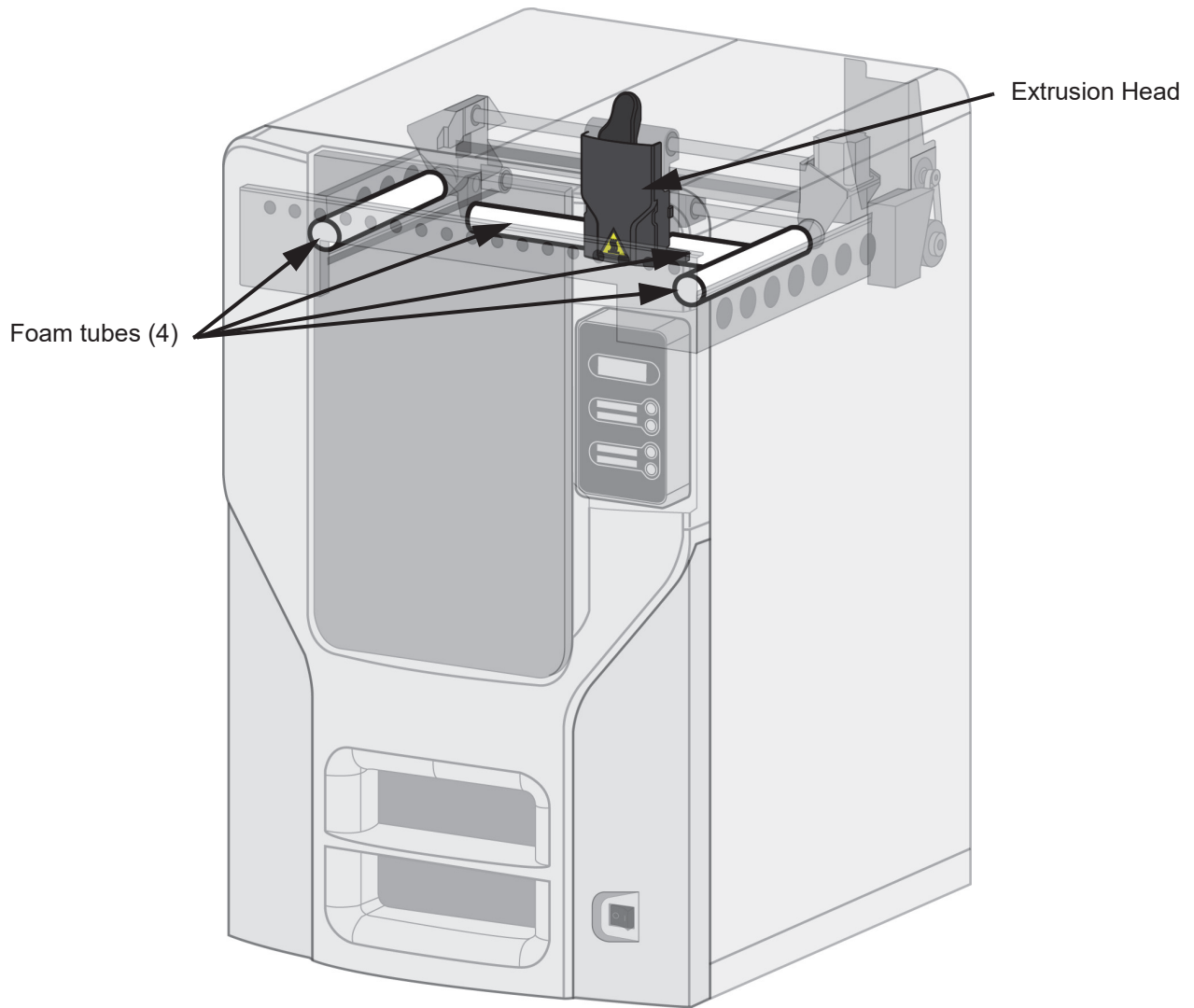

9. After unpacking, inspect the system and report any shipping damage to the carrier.

INSTALLING FORKLIFT ACCESS COVERS

The forklift access covers can be placed over the forklift channels after the system is placed in its final location. The covers are press-fit in the front and held in place with one screw in the rear.

1. Align the left and right side fork lift covers with the forklift channel and slide the tabs into the slots. See [Figure 3-2](#).

Figure 3-2: Installing the forklift access covers

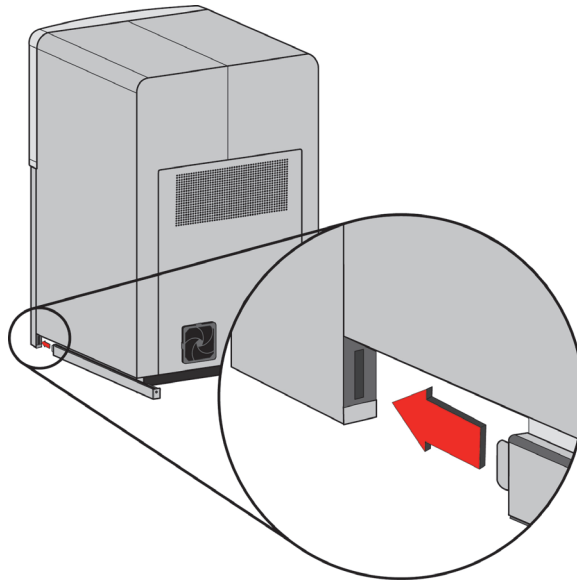

Insert tab in slot and push cover toward front of system

2. Push the forklift covers in until they are flush with the back of the system and install the mounting screws using a $\frac{1}{8}$ " T handle Allen wrench from the Startup Kit. See [Figure 3-3](#).

Figure 3-3: Installing forklift access cover mounting screws

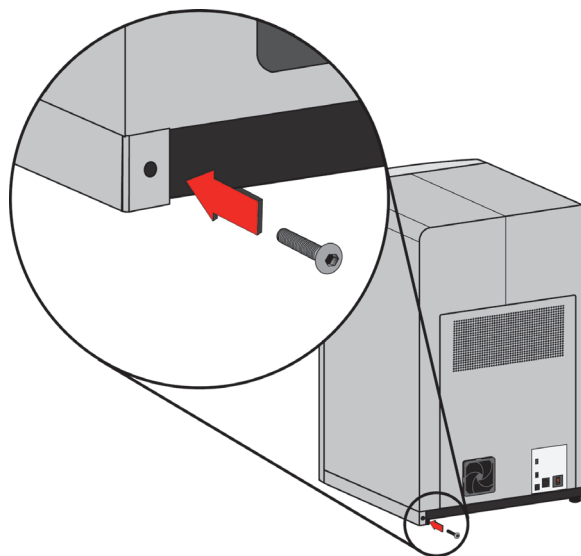

Attach screw at back of system

NETWORKING THE SYSTEM

There are two methods of connecting your system to your workstation, over a network or with a direct connection to your workstation.

CONNECTING THROUGH A NETWORK

1. Locate the network cable (blue) from the startup kit.
2. Connect the network cable between the system and the network hub. See [Figure 3-4](#).

[Figure 3-4](#): Connecting through a network

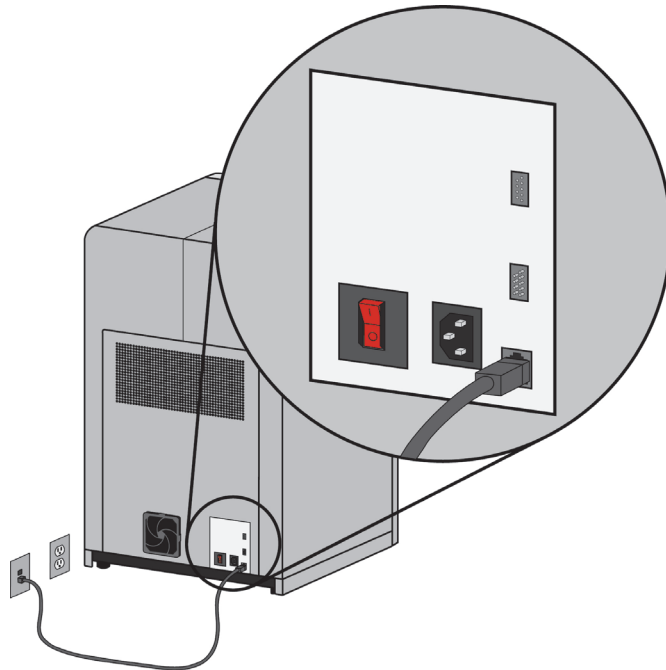

3. Establish communication, see [“Establishing communication on a dynamic network”](#) on page 17 if you have a dynamic network, or see [“Establishing communication on a static network”](#) on page 18 if you have a static network.

CONNECTING DIRECTLY TO A WORKSTATION

1. Locate the crossover cable (orange) from the startup kit.
 2. Connect the crossover cable between the system and the network port on your workstation. See [Figure 3-5](#).
 3. Establish communication, see [“Establishing communication on a static network”](#) on page 18
- [Figure 3-5: Connecting directly to a workstation](#)

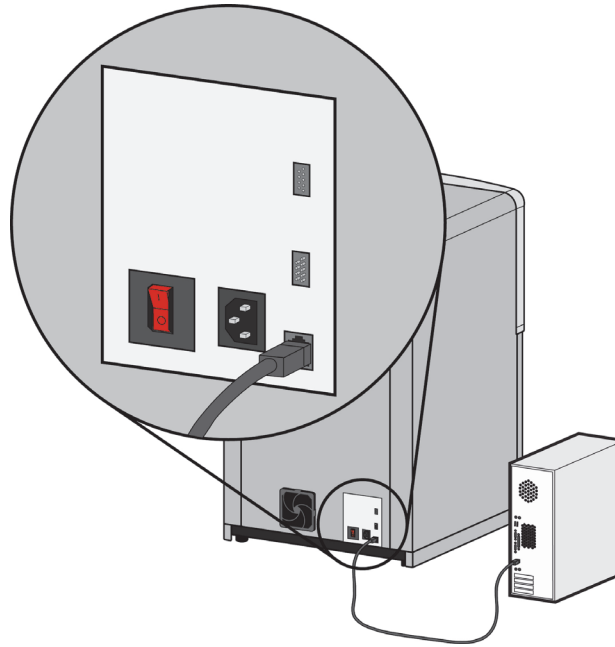

POWER CONNECTIONS

This section discusses the procedure for preparing all power connections for the system.



Caution: Before connecting power to the system, make sure that the circuit breaker is in the off (down) position. It is located at the rear of the system, next to the power cord attachment point.

The system is provided with two power cords: one for 110V (U.S. power cord) and one for 220V (Europe power cord).

1. Connect the male end of the supplied power cord directly into a grounded electrical outlet, as shown in [Figure 3-6](#). (If using a Uninterrupted Power Supply (UPS), connect the cord directly into the UPS.)
2. Connect the female end of the power cord directly into the rear of the cabinet. See [Figure 3-6](#).



Caution: Do not use an extension cord or power strip with the system. Connect the cord directly into the receptacle or UPS.

Figure 3-6: Connecting power

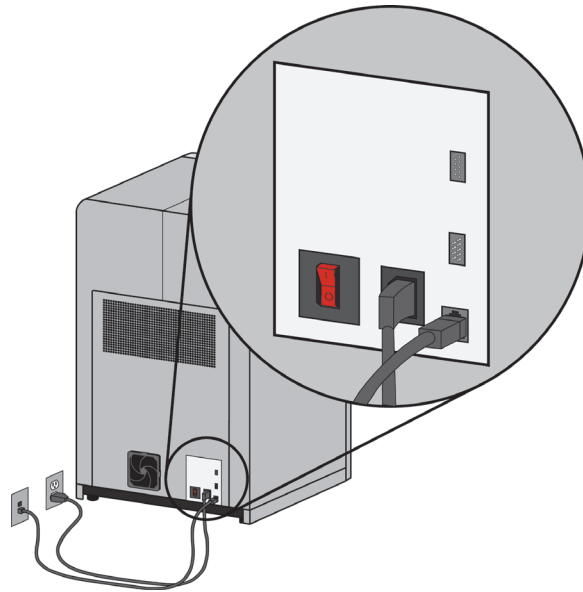

POWERING ON



Warning: The build chamber and extrusion-head tip get very hot! The chamber and head tip reach temperatures of approximately 75°C (167°F) and 280°C (536°F) respectively. Personal injury can occur if proper techniques and safety materials are not used. Use the leather safety gloves provided in the Startup Kit when working inside the system.

1. Switch the circuit breaker to the on (I) position. Power is now supplied to the system. The system is ready to be 'Powered ON'. See [Figure 3-7](#).

[Figure 3-7](#): Location of circuit breaker

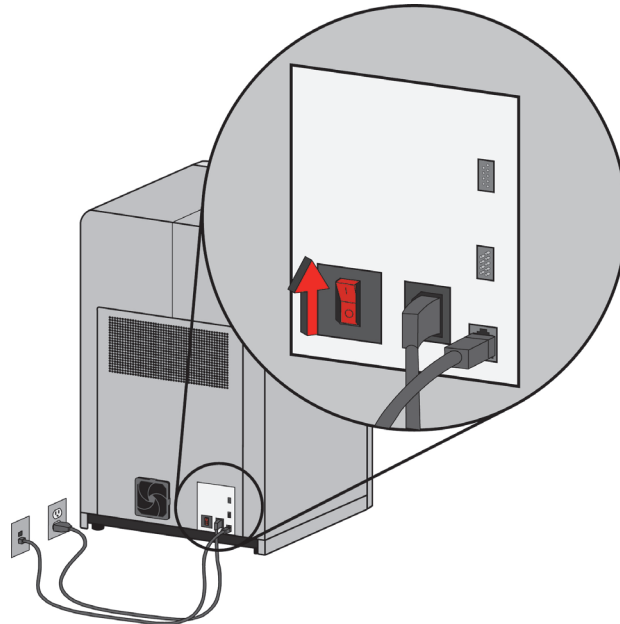

2. Turn the power switch to the on (I) position. See [Figure 3-8](#). After the switch is pushed, the system boots up in three to seven minutes.



Note: If the system was off and is at room temperature, it requires approximately 40 minutes to warm up before you can perform any functions. Temperatures are factory-preset and not adjustable. The panel displays the head and envelope temperatures while the system is warming up and cooling down.



Note: For safety, the head and Z Platform do not move while the chamber door is open. During warm-up and operation the door is locked. The door can be opened only when the system is not building a part, getting ready to build a part, or in Pause mode.

Figure 3-8: Location of power switch

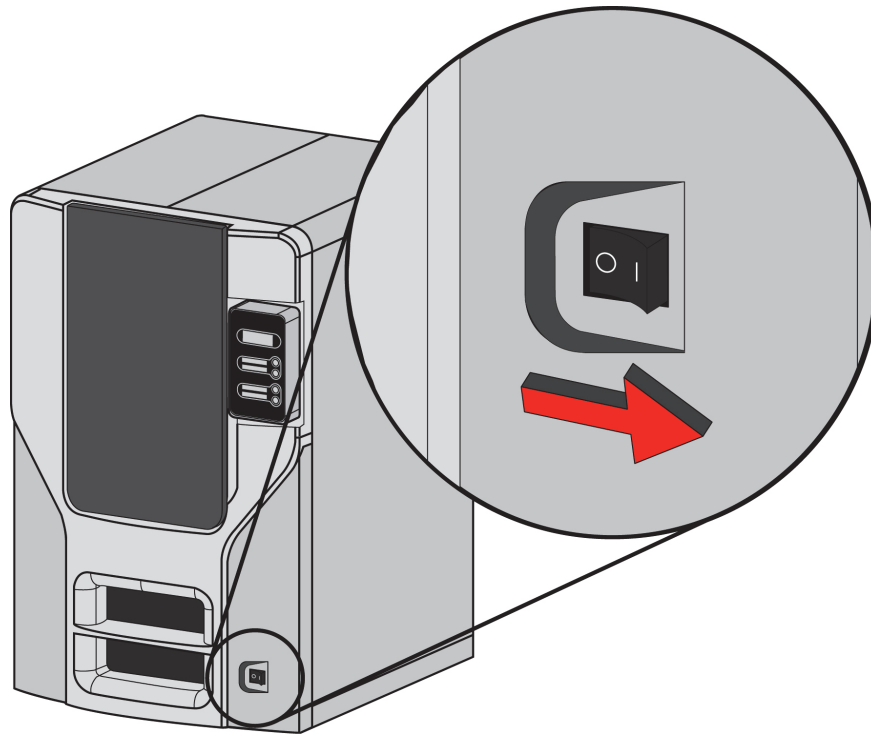

INSTALLING SOFTWARE

There are three software programs that work with the system:

1. Insight, the processing software installed on your workstation, processes the STL files for building.
2. Control Center, the communication software installed on the workstation, communicates with the system.
3. System software, the operating software installed on the system, controls system functions.

INSTALLING INSIGHT AND CONTROL CENTER

1. Locate the Insight CD from startup kit and insert into workstation (PC).
2. Follow prompts to finish loading Insight on the workstation. Control Center will be installed at the same time as Insight.

INSTALLING SYSTEM SOFTWARE TO THE WORKSTATION

1. Insert the System Software CD into the CD drive of your workstation.
2. Click the **Install** button to load system software to your workstation. You will be asked to load this system software to your system later.
3. Follow prompts to finish installing system software on the workstation.
4. Install system software to the system, see [“Installing System Software on system”](#) on page 20.

ESTABLISHING NETWORK COMMUNICATION WITH THE SYSTEM

You will need to establish network communication between your workstation and system before you can send files to be built. How you establish this communication with an IP address is dependent upon how your network and workstation are configured. If your network is configured for DHCP (Dynamic Host Configuration Protocol), your DHCP server will automatically assign a Dynamic IP address to your system. This is the default setting for your system and commonly used in large networks. In some situations you may need to manually enter a Static IP address for your system and record the IP address in the Control Center software. Static IP addresses are frequently used for smaller networks or for direct connection between your workstation and system. Follow the instructions below to configure your workstation and network.

ESTABLISHING COMMUNICATION ON A DYNAMIC NETWORK

If you are on a dynamic network (or not sure of your network type) follow these steps to allow Control Center to find your system and establish communication.

1. Connect a network cable between the system and a network hub.
2. Make sure the system is ON and determine the Unique Device Name (UDN) for your system.
 - A. From **Idle** (or **Ready to Build**), press **Maintenance** on the display panel. The display will show **Maintenance** and the software version.
 - B. From the display panel press **System**.
 - C. From the display panel press **Set Network**. The top window will display: **Network Admin - Dynamic IP Address; UDN**.
 - D. The Unique Device Name (UDN) for your system is listed here. This is preset at the factory and cannot be changed.
 - E. Press **Done** and exit **Maintenance**.
3. Make sure that UPnP (Universal Plug and Play) is enable on the system:
 - A. From **Idle** (or **Ready to Build**), press **Maintenance** on the display panel. The display will show **Maintenance** and the software version.
 - B. From the display panel press **Setup**.
 - C. The second option button will be to either enable or disable UPnP. If the system UPnP is enabled, the button option will be to **Disable UPnP**. If the system UPnP is disabled, the button option will be to **Enable UPnP**. Make sure the button option says **Disable UPnP**.
 - D. Press **Done** and exit **Maintenance**.
4. From your workstation, start the Control Center Software.
5. From the **Pack** tab, click the **Manage FDM Systems** button.
6. Click the **Add from Network** button in the lower right corner of the window.
7. A new window, **Add FDM System**, should list your system in the main window (identified by its UDN). Click on the system in this window and enter a name and location in the lower portion of the window.
8. Click **Add System** and you are ready to print. Close the **FDM Systems** window.



Note: If your system is not displayed in the “Add FDM System” window, the system UPnP may not be enabled or may not be working and you will need to set up a static network address.

ESTABLISHING COMMUNICATION ON A STATIC NETWORK

If you are using a static network or connecting the system directly to a workstation, you will need to enter the static IP address information into the workstation and the system. If you are using a static network and your computer already has network access, see “[Setting the static network on system](#)” on page 19.

1. Set the static IP address information in the workstation:
 - A. For Windows Vista, see “[Setting the static network in Windows Vista](#)” on page 18.
 - B. For Windows 7, see “[Setting the static network in Windows 7](#)” on page 18.
2. Set the static IP address information in the system, see “[Setting the static network on system](#)” on page 19.
3. Establish communication, see “[Establish communication](#)” on page 20.

SETTING THE STATIC NETWORK IN WINDOWS VISTA

1. From your workstation click on the **Start Menu**.
2. Click on the **Control Panel** button.
3. Double click on **Network and Internet**.
4. Double click on the **Network and Sharing Center** icon.
5. Left click on **Manage network connections**.
6. Right click on the **Local Area Connection** icon then left click on **Properties**.
7. Select **Internet Protocol Version 4 (TCP/IPv4)** from the list.
8. Click on the **Properties** button.
9. Click on the **Use the following IP address** option.
10. Enter the IP address, Subnet Mask and Default Gateway. Contact your IT Administrator or Internet Service Provider for details regarding IP address information. The IP address should be different from the workstation, the default gateway and subnet mask should match the workstation. Enter the IP address, default gateway and subnet mask.
11. Click on the **OK** button when finished. Close any open networking windows.

SETTING THE STATIC NETWORK IN WINDOWS 7

1. From your workstation click on the **Start Menu**.
2. Click on the **Control Panel** button.
3. Double click on **Network and Internet**.
4. Double click on the **Network and Sharing Center** icon.
5. Double click **Local Area Connection**.
6. Click on the **Properties** button.
7. Select **Internet Protocol Version 4 (TCP/IPv4)** from the list.
8. Click on the **Properties** button.
9. Click on the **Use the following IP address** option.
10. Enter the IP address, Subnet Mask and Default Gateway. Contact your IT Administrator or Internet Service Provider for details regarding IP address information. The IP address should be different from the workstation, the default gateway and subnet mask should match the workstation. Enter the IP address, default gateway and subnet mask.
11. Click on the **OK** button when finished. Close any open networking windows.

SETTING THE STATIC NETWORK ON SYSTEM

1. Obtain your static network address from your Network Administrator.
2. From **Idle** (or **Ready to Build**), press **Maintenance** on the display panel. The display will show **Maintenance** and the software version.
3. Press **System**.
4. Press **Set Network**. The top window displays: **Network Admin - Static IP Address; UDN**.
5. Press **Static IP** to display default settings.

IP Address: 172.016.075.020 or 198.000.000.001

NM Address: 255.255.000.000

GW Address: 172.018.100.002



Note: These values are the factory defaults and **MUST** be changed. If these values are not changed the system will continue to restart until they are changed.



Note: The IP address should be different from the workstation. The default gateway and subnet mask should match the workstation. Enter the IP address, default gateway and subnet mask.

-
6. Update the IP address:
 - Press **Increment** to increase the value one digit at a time.
 - Press **Next Digit** to move the cursor one place to the right.
 - Press **Last Digit** to move the cursor one place to the left.
 7. Use the three functions listed above to set your IP address.
 8. After setting the final digit of the Internet Protocol (IP) address, move the cursor one more place to the right. The cursor moves to the Netmask (NM) address. Follow the same steps for setting the Netmask (NM) and Gateway (GW) addresses.
 9. When you have finished setting the addresses, press **Done**. The display will show: **Change IP, Netmask and Gateway?**
 10. Press **Yes**. The panel then displays **Resetting Network..**
 11. Press **Done** until **Idle** is displayed.

ESTABLISH COMMUNICATION

1. From your workstation, start the Control Center software.
 - A. From the **Pack** tab, click the **Manage FDM Systems** button.
 - B. Click the **Add from Network** button in the lower right corner of the window.
 - C. A new window, **Add FDM System**, should list your system (identified by its UDN). Click on the system in this window and enter a name and location of your choice in the lower portion of the window.
 - D. Click **Add System** to complete. Close the **FDM Systems** window.
2. If your system is not displayed in the **Add 3D System** window, you will need to add the system IP address manually.
 - A. From the **Pack** tab, click the **Manage FDM Systems** button.
 - B. Click the **Add Manually** button in the lower right corner of the window.
 - C. In the **Add FDM System** window, enter a name and location of your choice in the appropriate fields.
 - D. Enter the IP Address for your system in the appropriate field. It will be the same address as entered in step 6.
 - E. Select your system type from the drop down list, Fortus 250mc.



Note: If you only have one system connected, it will be the only system in the list.

- F. Click **Add System** and close the **FDM Systems** window.
3. If you are unable to connect the system to your workstation, contact your Network Administrator.

INSTALLING SYSTEM SOFTWARE ON SYSTEM

1. From the display panel, press **Maintenance**.
2. Press **System**.
3. Press **Load Upgrade**. “Send upgrade from workstation” and the system IP address will be displayed.
4. From your workstation, open Control Center by double clicking on the Control Center icon.
5. Click the **Services** tab.
6. Select your system from the drop down list then click the **Update Software** button.
7. Navigate Control Center to the directory where the system software file is located and select the 250mc.upg file. System software will now begin to download to the system.



Note: Default system software location for 32 bit systems:

C:\Program Files\Fortus\250mc <version>

Default system software location for 64 bit systems:

C:\Program Files\x86\Fortus\250mc <version>

8. When system software verification is complete, the system display will show **Reboot to complete upgrade?** Press **Yes**. The system will then load the system software then reboot and return to **Idle**.



Note: Loading system software will take approximately 10 minutes.

INSERT MODELING BASE

Make sure retainers are turned 'down' - so as not to interfere with the modeling base installation. Set the modeling base on the Z Stage Platen aligning the tabs on the modeling base with the slots on the metal tray. Slide the modeling base toward the back of the unit until its front edge (with the handle) is flush with the front edge of the tray, see [Figure 3-9](#). Secure the base with the two retainers by turning them up.



Note: When inserting and removing the modeling base, use the handle to avoid touching the top surface. Grease and oil that contact the top build surface could cause poor part adhesion. You can clean the build surface with isopropyl alcohol if necessary.

Figure 3-9: Inserting a modeling base

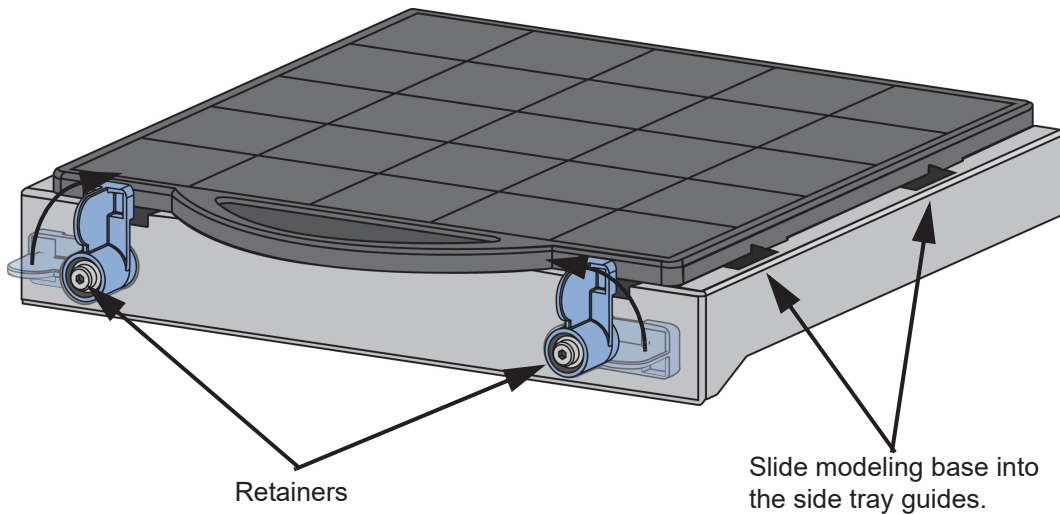

4 OPERATION

DISPLAY PANEL AND KEYPAD

The main User Interface to the system is the Display Panel and Keypad, see [Figure 4-1](#).

Figure 4-1: Display panel and keypad

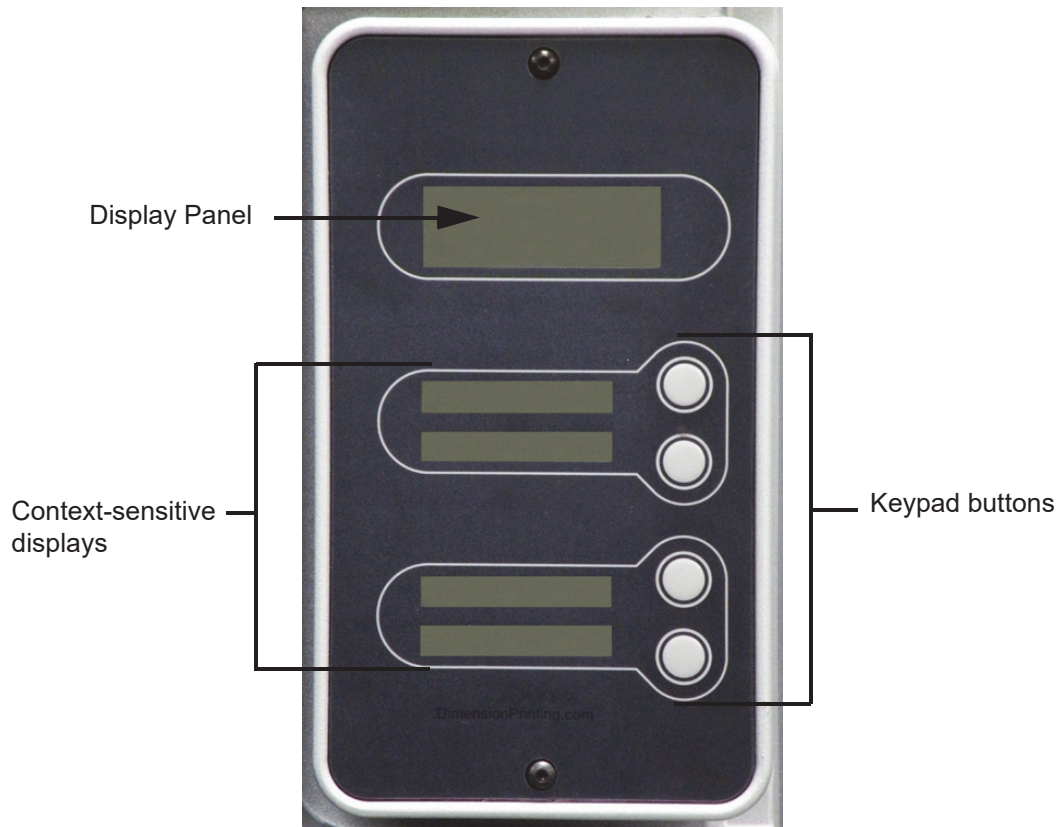

The display panel and keypad are very easy to use, consisting of a larger multiple-line LCD display on top, and four single-line context-sensitive displays, each with one button (or key) below. The top line in the large display always shows system status. The lower three lines of the large display show details related to the current operation.

At times there will be an item blinking in the lower (context-sensitive) displays. The blinking item is usually the most logical selection.

SYSTEM SOFTWARE OVERVIEW

- **Idle:** If there is no part being built and no part in the build queue, the display will show that the system is **Idle**.
- **Wait for Part** or **Start Part:** If the system is in Idle and the build queue is empty, you can set it to wait for a part. If the system has a part in the build queue, you can press **Start Part** to start a build.
- **Building:** If the system is building a part, you can choose to pause, set the lights either ON or OFF, view the print time or material remaining and set the system to auto power down.
- **Material:** From this section you can load material or unload material.
- **Standby:** From this section you can set the system to Standby mode.
- **Maintenance:** From this section you can make changes to the **System, Setup** or **Machine**.

Figure 4-2: Display panel hierarchy

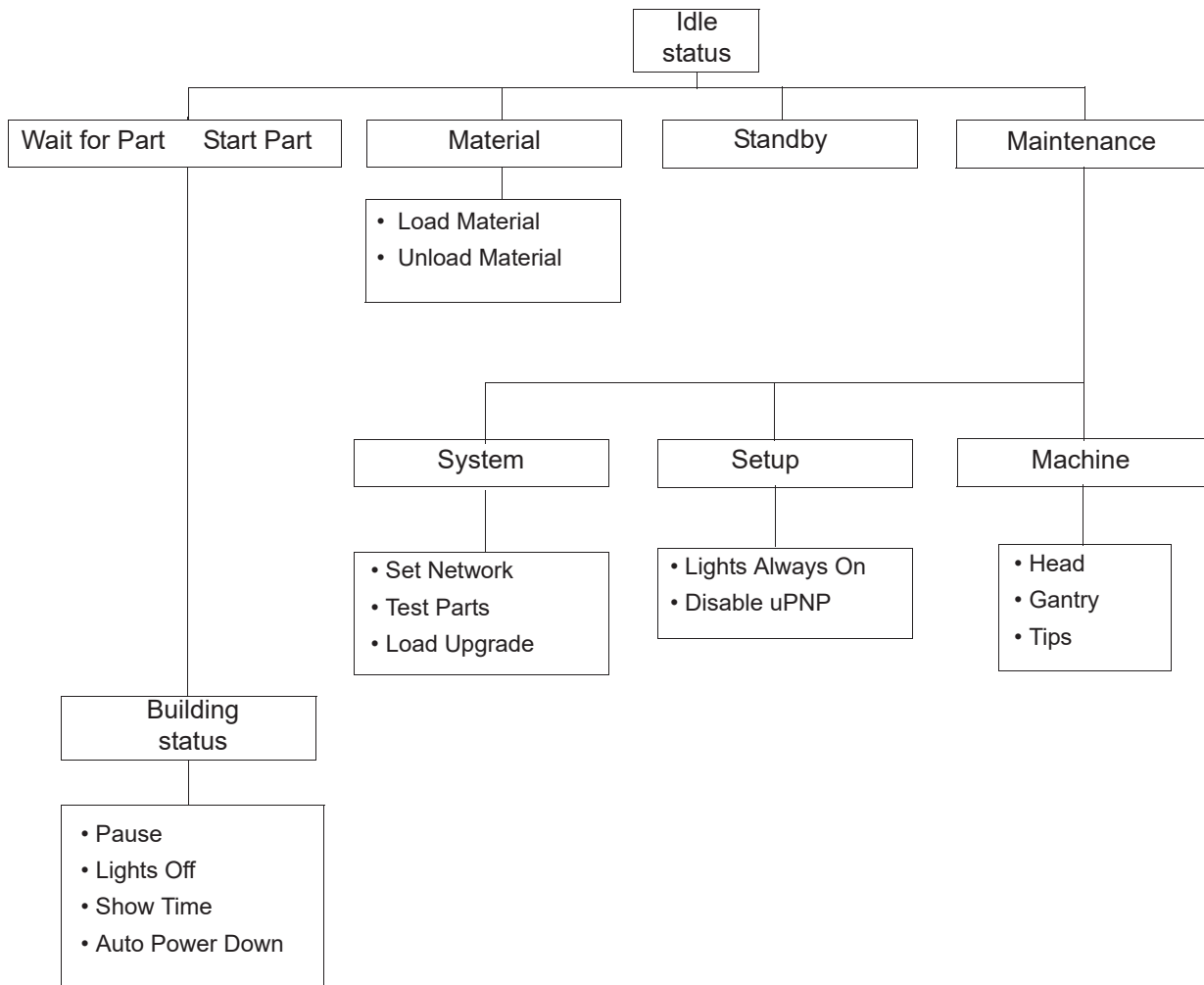

CONTROL CENTER OVERVIEW

- **Pack tab:** This section shows you which parts are in the pack for printing. You can add parts, arrange the parts for a better fit or clear the pack from this section.
- **Queue tab:** This section shows you the amount of material remaining (both model and support) as well as which parts are in the Build Queue.
- **Systems View tab:** This section shows you system information. The left side of the screen displays modeler information and the right side of the screen displays the job schedule.
- **Services tab:** From this section you can check the system history, set the system time, set the system password, update system software, get system info and export configuration files (files containing specific operating information regarding the system).

Figure 4-3: Control Center hierarchy

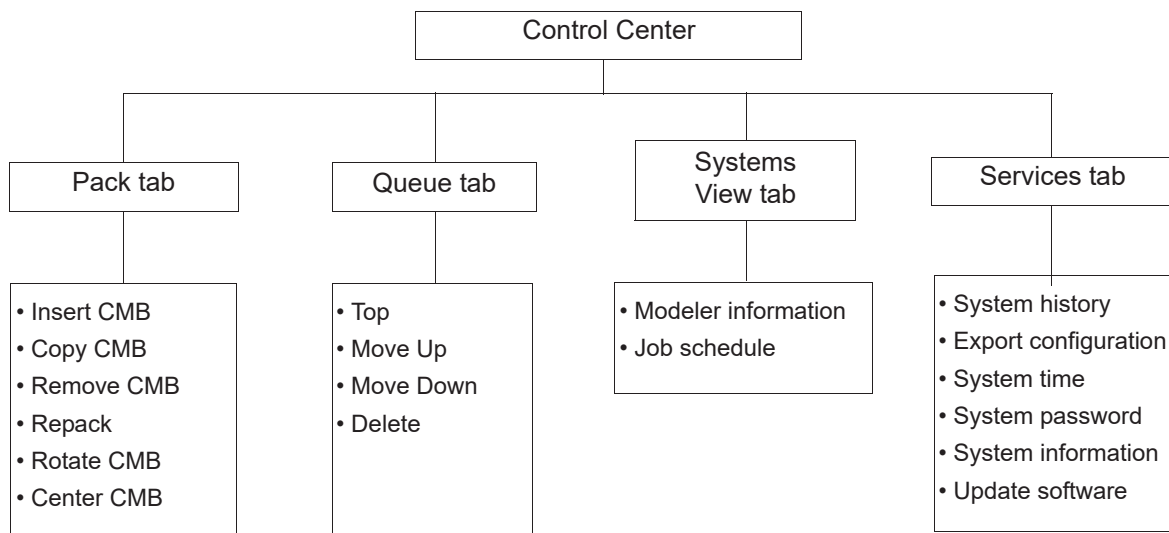

Note: For detailed information refer to Control Center Dynamic Help.

PROCESSING YOUR STL FILE FOR PRINTING

OPENING YOUR STL FILE WITH INSIGHT

1. Create an STL file using your CAD software. Refer to your CAD software help section for more information about converting your CAD drawings into STL files.
2. Open the Insight software.
3. From the **File** menu select **Open STL...**
4. Navigate to and select the STL file that you have created.

SELECTING LAYER RESOLUTION

Layer resolution can be changed on the system. Changing layer resolution will affect surface finish and build times. Selecting a smaller layer resolution creates a smoother surface finish, but takes longer to build. Layer resolution also affects the minimum wall thickness. Minimum wall thickness applies to the horizontal (XY) plane of your part. If a feature in an STL is smaller than the limit, the modeler will increase the size of the feature to the minimum wall thickness.

Available layer resolutions	Minimum Wall thickness
.007 inch (.178 mm)	.025 inch (.635 mm)
.010 inch (.254 mm)	.036 inch (.914 mm)
.013 inch (.330 mm)	.047 inch (1.194 mm)

SELECTING MODEL INTERIOR FILL STYLE

This establishes the type of fill used for the interior areas of the part. There are three types of model interior that you can choose from.

- **Solid** - Used when a stronger, more durable part is desired. Build times will be longer and more material will be used.
- **Sparse High Density** - This is the default model interior style and is highly recommended. Build times will be shorter, less material will be used and the possibility of part curl for geometries with large mass will be greatly reduced.
- **Sparse Low Density** - The interior will be “honeycombed” or “hatched”. This style allows for the shortest build times and lowest material usage but will decrease the strength of the part.
- **Sparse Double Dense** - Minimizes the amount of model material used, but utilizes a crosshatch raster pattern (instead of uni-directional) for added strength. Top and bottom exposed layers are built with the solid raster pattern.

SELECTING SUPPORT STYLE

Support material is used to support the model during the build process. It is removed when the part is complete. Support styles will affect the support strength and build time of the print. SMART support is the default support setting.

- **Basic** - May be used for most parts. Basic support uses a consistent spacing between support toolpaths.
- **SMART** - minimizes the amount of support material used, reduces the build time, and improves support removal for many parts. SMART supports use a wide spacing between toolpath rasters and change the shape of the support region. As the supports descend from the underside of the part feature to the base of the supports, the support region shrinks and transforms to a simpler shape to reduce the amount of material used and the build time. SMART supports are suitable for all parts, especially those with large support regions, and are the default style for builds using soluble supports
- **Surround** - The entire model is surrounded by support material. Typically used for tall, thin models.
- **Sparse** supports will create supports that use less material than basic supports. This is accomplished by creating a new raster fill pattern that has a much larger air gap. Like basic supports, the top layer of a support column is built with a solid pattern of rasters. The next several layers have the basic raster pattern that has a small air gap. Progressing downward, a new sparse support region is used below the several layers of basic support raster fill. The sparse support regions use a much larger air gap when building the toolpath rasters. In addition, the region is surrounded by a single closed toolpath-perimeter curve.

As the supports progress downward, it is possible to see all three support-fill types in a single layer: 1) top of support solid-filled, 2) basic supports with small air gap, and 3) sparse supports with large air gap. Sparse supports are suitable for all parts, especially tall parts and parts requiring large supports.

- **Break-away** supports are similar to sparse supports but consist of boxes instead of a continuous raster. There is no closed toolpath-perimeter curve around the break-away supports. They are easier to remove than other support styles for some materials but build slower than sparse supports. Break-away supports are not recommended for use with soluble support materials.

SELECTING THE SCALE OF YOUR STL FILE

Before you process a part for printing, you can change the size of the part within the build envelope. Every part has a pre-defined size within the STL file. After you have opened the file you can change the size of the part produced from the STL file by changing the scale. The scale always relates to the original STL file size definition.

For example: a cube that is defined as 2 X 2 X 2 can be built to be 4 X 4 X 4 by simply changing the scale to 2.0. If after changing the scale to 2.0, you decide that a size of 3 X 3 X 3 would be preferred, change the scale to 1.5 - the scale relates to the original size of 2.0, NOT the resulting 4.0 from the first scale change.

Click within the scale input box to type a scale of your choice.

SELECTING THE ORIENTATION OF YOUR STL FILE

How a part is oriented in the preview window will determine how the part is oriented when it prints.

Orientation impacts build speed, part strength, surface finish and material consumption. Orientation can also affect the ability of Insight to repair any problems with the STL file.

You can choose to auto orient your part, which allows Insight to determine the best orientation for the part for the fastest build time and least material usage, or you can manually change the orientation of your part.

Orientation Considerations:

- **Build Speed** - Closely related to material use. A lesser amount of supports will allow for a faster build speed.

Another factor affecting build speed is the axis orientation. The system can build faster across the X-Y plane than it can along the Z axis. Orienting a part so that it is shorter within the modeling envelope will produce a quicker build.

- **Part Strength** - A model is stronger within a layer than it is across layers. Depending upon what features you want your part to demonstrate, you may need to orient your part to have its greatest strength across a specific area. For example a tab that needs to be pressed would be weakest if you are applying pressure across layers.
- **Surface Finish** - Much like orienting for strength, how the part is oriented will determine how the surface finish will look and allow the system to provide the smoothest finish for a specific area. For example, if building a cylinder, orienting the cylinder upright will have a smoother surface finish than building it on its side.
- **STL File Repair** - It is possible for an STL file to have errors while appearing to be trouble free. If the STL file contains errors, Insight may have problems processing the file. Insight has the ability to automatically correct some STL file errors. How the part is oriented can impact this automated repair function.

SELECTING THE VISIBLE SURFACE STYLE OF YOUR STL FILE

Choose Enhanced or Normal. The intent of this feature is to improve part appearance without negatively impacting build throughput.

- **Normal** - No change from prior behavior.
- **Enhanced** - The default choice is Enhanced; independent controls are used for the visible surface rasters and the non-visible, internal rasters. Use the Visible surface rasters option to control the raster width of the visible surface rasters. Use widths smaller than normal to improve the visible appearance. Internal non-visible regions are filled with Interior rasters, which can be assigned a wider toolpath width. Multiple output contours are optionally used on visible layers to hide the raster turn-arounds from view. Up to Surface max contours are used to hide the raster turn-arounds. On layers with a larger visible exposure, the default contour parameters are applied to the layer.

The degree to which this feature affects build time also depends on the amount of internal raster fill that can now use wider rasters.

For the ideal case of a cube, which is mostly filled with internal rasters, build time may be reduced by almost one third.

A complex shape or thin-walled part, where most regions are subdivided between visible surfaces and internal regions, may see little benefit. The faster build speed of wider internal rasters is offset by the inefficiency of using more individual toolpaths to fill the regions.

The other Part interior style fill types, Double Wide and Sparse, can be used with visible surface detection - the features are independent and complementary.

PROCESSING YOUR STL FILE

To finish preprocessing the STL file with the default presets:

1. Click on the  (**Finish**) button to finish all remaining preprocessing for the STL file and create the CMB file.



Note: Clicking on the **Finish** button will process the STL file with the default processing presets. For more information on processing STL files, refer to Dynamic Help or consult your local Reseller for Insight training.

2. Click on the  (**Build**) button to send the CMB file to the Control Center software.

PRINTING YOUR CMB FILE

The **Build Job** button is found on the Pack tab.

Once build job settings have been accepted, the CMB file will open in the Control Center software.

ADDING YOUR CMB FILE TO THE PACK

The **Insert CMB** button is found on the Pack tab.

When you click on the **Insert CMB** button, Control Center will add the file that you select to the pack preview window (Pack tab).

OPENING YOUR CMB FILE WITH CONTROL CENTER

1. Open the Control Center.
2. From the **File** menu select **Open CMB...**
3. Navigate to and select the CMB file that you have created.

INSERTING A MODELING BASE

Prior to inserting a modeling base into the tray, remove any material buildup on and behind the Z Platform and around the lead screw. Failure to do so could cause the modeling base to be unlevel or, if the amount of buildup is large enough, the Z Platform could jam at its upper limit.

Install the modeling base. See [“Insert Modeling Base” on page 21](#).



Caution: DO NOT reuse modeling bases. If a modeling base is reused, calibration errors, poor part quality, and loss of extrusion may occur. Additional modeling bases are available from your reseller.

BUILDING A PART

If a part has not been sent to your system for building, the build queue will be empty. If the build queue is empty the display panel will show **Idle** or **Ready to build**.

Choose whether or not you want to start a build from a remote location or from the display panel at the system.

STARTING A BUILD FROM A REMOTE LOCATION

1. To start a build from a remote location, the system must first be prepared to start the build.
2. From the display panel press **Wait for Part**. The display will ask **Is Model Base Installed?**
3. Insert a modeling base.



Caution: DO NOT reuse modeling bases. If a modeling base is reused, calibration errors, poor part quality, and loss of extrusion may occur. Additional modeling bases are available from your reseller.

4. Press **Yes**. **Waiting for Part** will now be on the display.
5. From your Control Center workstation, send a part to the system. The system will automatically start to build the part. See “[Processing your STL file for printing](#)” on page 25 for detailed instructions.

STARTING A BUILD FROM THE DISPLAY PANEL

If **Wait for Part** has not been activated, you can send the part to the system and start the part from the display panel after the part has been sent to the system.

1. From your Control Center workstation, send a part to the system. The display will show **Idle/Ready to Build** and the name of the first file that is in the queue waiting to be built.
2. Insert a modeling base.



Caution: DO NOT reuse modeling bases. If a modeling base is reused, calibration errors, poor part quality, and loss of extrusion may occur. Additional modeling bases are available from your reseller.

3. From the display panel press **Start Model** to start building the part.

LOADING MATERIAL

Material cartridges are factory packaged in a box and an anti-static, moisture-proof bag to preserve shelf life. It is recommended to keep the material in the sealed bag until it is going to be loaded into the printer to keep the material from absorbing moisture.

LOAD MATERIAL CARTRIDGES

1. Remove packaging.
2. If present, remove the red sealing plug from the cartridge: (see [Figure 4-4](#)).



Note: Plug must be removed before cartridge can be installed.

- A. Turn the plug a quarter turn counter clockwise.
- B. Lift up the plug to remove it from the cartridge - discard (or recycle) the plug.

[Figure 4-4](#): Remove red plug before loading

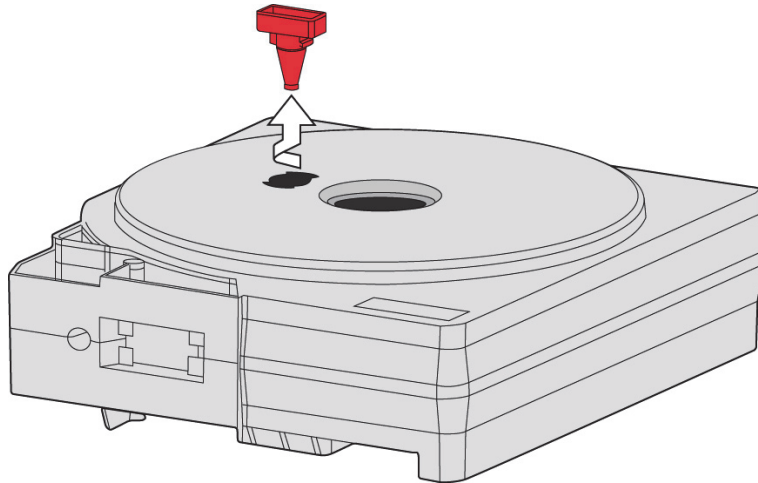

3. Find the end of the material taped with a “flag”.



Caution: Be careful when touching the pinch roller on the side of the cartridge. See [Figure 4-5](#) for the correct direction to move the cartridge roller. If you roll it backwards, you could draw the material into the cartridge.

Figure 4-5: Direction to move cartridge roller

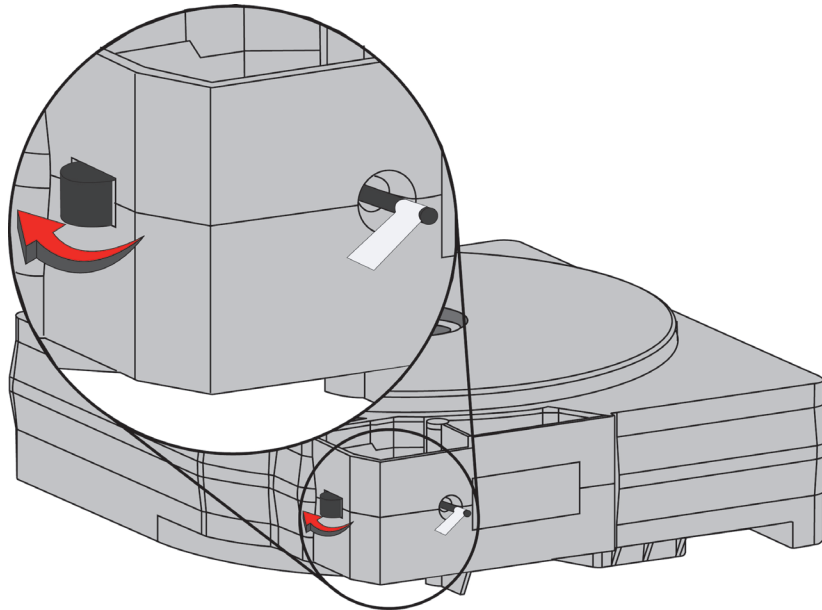

4. Pull material out of cartridge to expose about 12 inches of material. You should easily be able to pull out the material.



Note: The above step makes sure that the material will feed freely from the spool.

5. With the cutter from your Startup Kit, snip the material flush with the end of the cartridge, see Figure 4-6.

Figure 4-6: Snipping the material

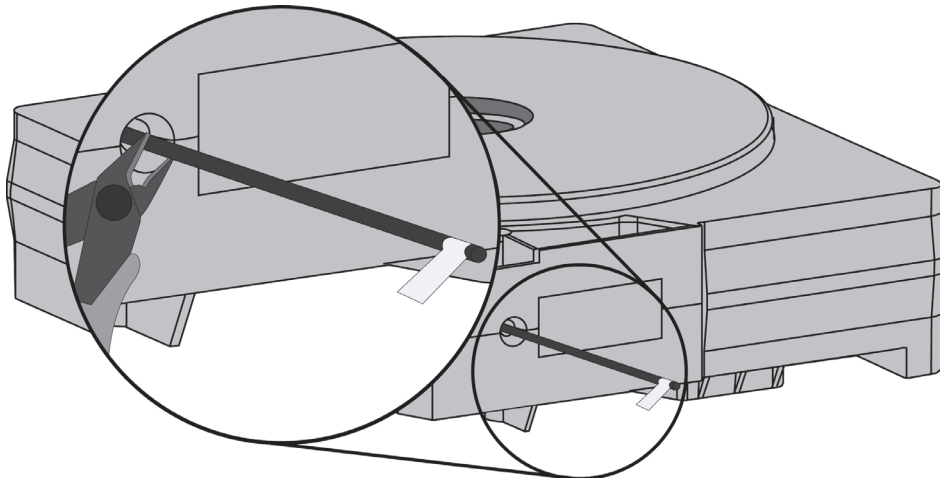

6. If the system is in **Idle**, press the **Material...** button, which will be blinking.
7. Display will prompt with **Material - Add/Remove** (flashing).
8. Insert material cartridges into their appropriate slot from the front of the system (Model material cartridge goes in the Top slot; Support material goes in the Bottom slot).
9. When the cartridges have been inserted, press **Load...** (flashing).
10. Display will prompt with **Load Both...**, **Load Model...** or **Load Support...** Press **Load Both...**
11. After material has been loaded to the head press **Done...**

UNLOADING MATERIAL

The model and support material cartridges may be replaced separately or at the same time. In idle-, load-, or build-related modes, the panel displays the percentage of material remaining in the cartridges. If the system will be operating unattended for a long period, and the material level is getting low, you may want to replace the cartridges before starting a new part. Of course, you will also need to replace the cartridges when they are empty.

UNLOAD MATERIAL CARTRIDGES

1. From **Idle**, Press **Material...**
 - A. Press **Unload...**
 - B. The panel displays **Material** and prompts with, **Unload Both..., Unload Model... or Unload Support...**
 - C. After you have made the above choices, the panel displays **Unloading** for approximately 60 to 75 seconds (the selected materials will be unloaded from the extrusion head).
 - D. When unloading is complete, the panel will prompt you to remove a cartridge based upon your choices - i.e., **Remove Model Cartridge**, or **Remove Support Cartridge**.
2. Remove the material cartridge(s) by first pushing it forward gently, and then pulling it out of the slot.



Caution: Do NOT try to rewind the material that remains in the system. This will cause material to cross-wind in the cartridge causing cartridge failure.

- When you remove a cartridge there will be approximately 180 cm (6 feet) of material that will need to be pulled from the system. (This is normal. Material is only retracted from the extrusion head during 'unloading'.)
3. To store a partially used cartridge, place a small flag of tape on the material near the cartridge. Cut off and discard the remaining material. The tape flag ensures the material does not retract into the cartridge.



Note: Storing a partially used cartridge in a sealed bag will help prolong the shelf life of the material.

BUILDING A TEST PART

Factory test parts have been preloaded into your system. To familiarize yourself with the system, it is recommended that you build one of the test parts before attempting to build one of your own files.

Once the system has warmed up, material has been loaded, and a modeling base is in place, you can send a test part to the system.

BUILD A TEST PART

1. Press **Maintenance**.
2. Press **System**.
3. Press **Test Parts**, and select one of the available sample parts.

The system automatically starts building the part.

4. When the part is finished, follow the steps under “[Removing a Completed Part](#)” on page 36.

THE DISPLAY PANEL DURING BUILD

The top two lines of the display panel show system-status messages, see [Figure 4-7](#). The bottom line of the panel shows the material amounts remaining in the cartridges.

Figure 4-7: Display panel during build

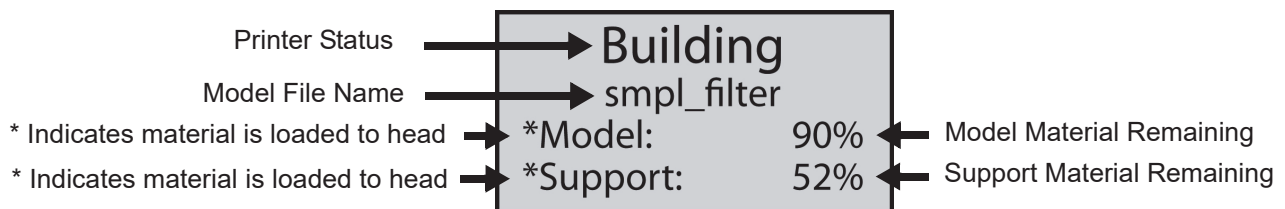

CHAMBER LIGHTS

When a part starts to build, the chamber lights are automatically ON. You can toggle lights ON or OFF through the Display Panel.

You can also turn the light on continuously. Go to the **Idle** or **Ready to Build** mode. Press **Maintenance** and then press **Setup**. Press **Lights Always On**. The light will remain ON until the system is powered OFF.

PAUSING BUILD

While building a part, you may want to pause the operation - e.g., to allow for replacement of a material cartridge. To pause the build operation at any time, press **Pause**.



Note: When the build process is paused, the system completes the current tool path before pausing.

RESUMING BUILD FROM PAUSE MODE

If you have pressed **Pause**, and are ready to resume building the part, press **Resume**. The system resumes modeling.

RESUMING OPERATIONS FROM STANDBY MODE

After several minutes of inactivity, the system enters Standby mode. During Standby, the head temperature will decrease to save energy.

CONTINUE OPERATION FROM STANDBY MODE

1. Press **Resume**.
 - The panel displays **Ready to Build** and your part's name (if there is a part in the queue). It also shows the amount of material remaining in the model material cartridge and the support material cartridge (e.g. ***Model 90%**, ***Support 85%**).
 - **Start Model** begins blinking.
2. Press **Start Model** to begin modeling.
(The system may require a few minutes to warm up to proper build temperatures. You can view the temperature values in the display.)

CANCELING A JOB

You can cancel a job at any time while the part is building.

CANCEL A JOB

1. Press **Pause**.
2. Once the system stops building, press **Cancel Build**.
The panel displays **Are you Sure?**
3. Press **Yes**. The panel displays **Build Stopped** followed by the part name.
4. The panel prompts you to remove the part and replace the modeling base. See [“Inserting a Modeling Base” on page 28](#). Once the chamber door has been opened and closed, the panel asks: **Part Removed?**
5. Press **Yes only after** removing the part - refer to [“Removing a Completed Part” on page 36](#).



Caution: If you press **Yes** before removing the part, the system can be damaged, and a service call will be required.

AUTO POWER DOWN

You can set the system to automatically power down when a build is complete. This option will save energy usage.

1. While the system is building, press the **Auto Power Down** button.
2. Turn the power switch, located on the left side of the system, to the OFF position.

The system will display **Auto Power Down Mode** and the system will power down as soon as the build is complete.

CANCELING AUTO POWER DOWN

To cancel Auto Power Down, turn the power switch back to the ON position.

POWERING OFF

To power-off the system, move the power switch to the OFF position, see [Figure 3-8 on page 16](#). You can do this at any time without harming the system. No other steps are necessary. If this is done while the system is building a part, the current build will be lost. System cooling fans will continue to operate for several minutes. This ensures a safe, systematic power down.



Note: For extended non-use periods greater than 72 hours, unload the material cartridges and power off the system.

REMOVING A COMPLETED PART

When the part has completed, the panel displays **Completed Build**, and the file's name. It also shows **Remove Part and Replace Modeling Base**.

REMOVE A COMPLETED PART

1. Open the modeling chamber door.
2. Release the modeling base retainers and pull the modeling base towards you, out of the tray guides.
3. Insert a new modeling base.
4. Close the modeling chamber door.
5. After you have opened and closed the door, the panel displays **Part Removed?** only after removing the part, press **Yes**.



Caution: The system can be damaged if you answer **Yes** and the part has not been removed.

-
- After you press **Yes**, the panel displays the status as **Ready to Build** for the next part in the queue.

REMOVE A COMPLETED PART FROM THE MODELING BASE

1. After removing the base from the system, firmly flex the modeling base back and forth with your hands to loosen the part. For best results, flex the modeling base front-right to back-left.
2. Pull the part off the base.



Note: Supports are much easier to remove when the part is still warm.

REMOVING SUPPORT MATERIAL

SOLUBLE SUPPORTS



Warning: When removing soluble supports by hand, wear leather gloves and safety glasses.

Fortus 250mc uses soluble supports - designed to allow you to simply wash away the support material in a water-based solution. Your part is left smooth and clean with the fine details intact. The soluble support material can be removed by hand with relative ease, but is designed to be dissolved off of your parts for hands-free part finishing. Contact your Reseller for information regarding support removal equipment.

5 MAINTENANCE

UPDATING CONTROLLER SOFTWARE

The Controller software can be updated by using one of the two methods described below:

WEB METHOD (PREFERRED METHOD)

This method is for customers who have web access.

1. Open the Control Center application and select the **Services** tab and then click **Check for System Updates**.
2. The Stratasys Update Manager window will appear. The application will check to see if the Controller software is current. Follow screen prompts to update the Controller software.

Figure 5-1: Control Center

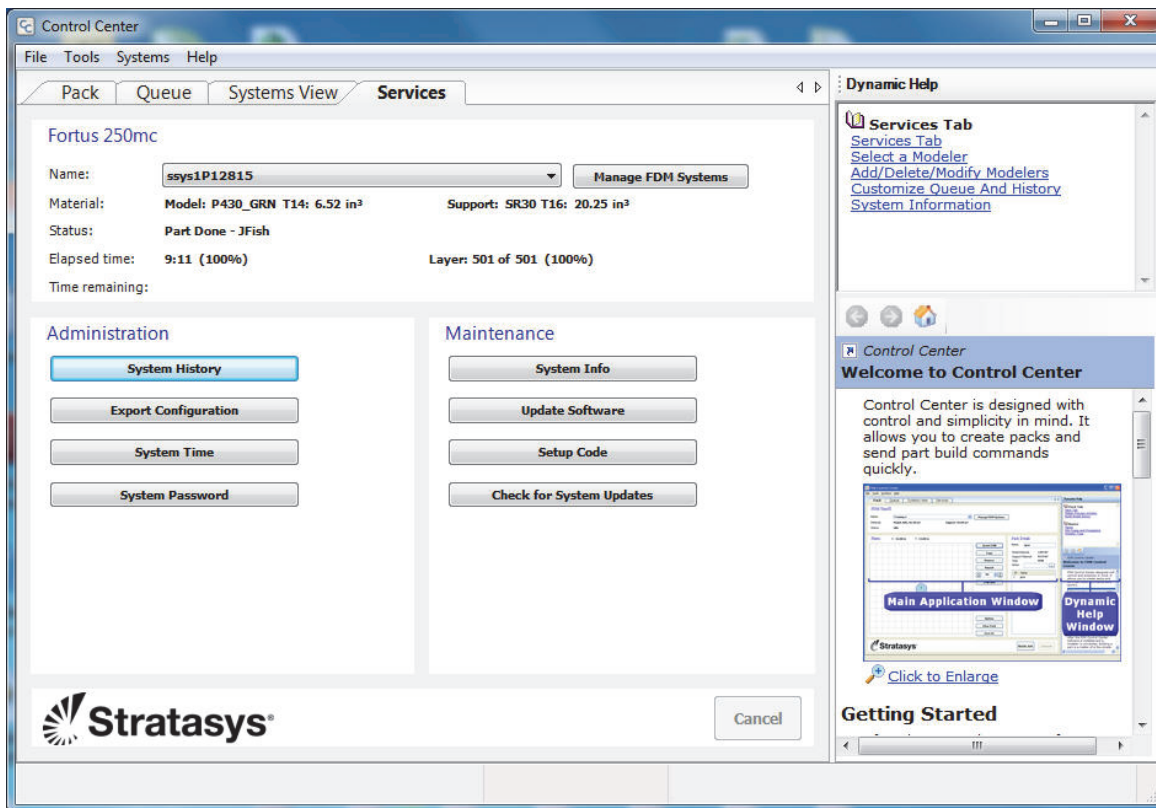

CD METHOD (ALTERNATE METHOD)

This method is for customers who do not have web access. The Controller Software Update CD containing the updated .upg file and must be obtained from Stratasys, Inc.

1. Insert the Controller Software Update CD into the workstation computer.
2. Make sure the system is placed in the receive software upgrade mode. (See “[Placing System in Receive Software Upgrade Mode](#)” on page 38.)
3. Open the Control Center application and select the **Services** tab and then click **Update Software**. (See [Figure 5-1](#) on page 37.)
4. Browse to the location of the .upg upgrade file on the Controller Software Update CD.
5. Select the .upg file to be downloaded and then press **Open**. This will send the file to the Fortus 250mc.
6. When the download is complete, select **Reboot and Install Software Upgrade** and then press **OK** at the Fortus 250mc system.
7. After the system reboots and the upgrade installation complete, two options will appear; select **Auto Home XYZ**.

PLACING SYSTEM IN RECEIVE SOFTWARE UPGRADE MODE

Place the system in software upgrade mode by doing the following:

1. Place the modeler in the Upgrade mode ([Maintenance](#) > [Administration](#) > [Receive Software Upgrade or Code](#)).
 - The operator panel will display the following message.

```
>Waiting for Software Upgrade or Code  
Press MENU key to Cancel
```

2. The system is now in the receive software upgrade mode.

STARTUP KIT TOOLS

The Startup Kit contains replacement parts and a set of tools used to help you maintain the system. The following is a list of the tools contained in the Startup Kit.

- Needle Nose Pliers
- T-Handled Wrench - $\frac{1}{8}$ "
- T-Handled Wrench - $\frac{7}{64}$ "
- Leather Insulated Gloves (Pair)
- Cutters
- Brush (bronze)
- Magnifier

PREVENTIVE MAINTENANCE

Follow the simple procedures within this chapter to ensure continued proper operation of the system.

DAILY

INSPECT THE TIP WIPE ASSEMBLY

After each build you should inspect the tip wipe assembly to make sure there is no material build up or wear. If there is material build up or wear, clean the tip wipe assembly. Material build up on the tip wipe assembly can cause part quality issues. See [“Replace the tip wipe assembly” on page 42.](#)

INSPECT THE TIP SHIELDS

After each build you should inspect the tip shields for damage or material build up. If there is material build up remove it as needed. If the material will not break free or there is damage to the tip shield, replace the tip shield. See [“Tip shield replacement” on page 43.](#)

REMOVE DEBRIS BUILDUP

Remove all material buildup on the Z platform and around the lead screw. Failure to do so could cause the base to not be level or the Z platform to jam at its upper limit.

VACUUM BUILD CHAMBER

Vacuum the build chamber to remove all debris and purged material.

CLEAN DOOR

The door glass can be cleaned with any commercial glass cleaner.

EMPTY THE PURGE CONTAINER

The plastic purge container is attached to the right side of the modeling envelope rear wall, see [Figure 5-2](#).



Note: A full purge container may impact part quality.

1. Remove the purge container by grasping it and pushing it upward to release it from its three mounts. See [Figure 5-2](#).

[Figure 5-2](#): Purge container location

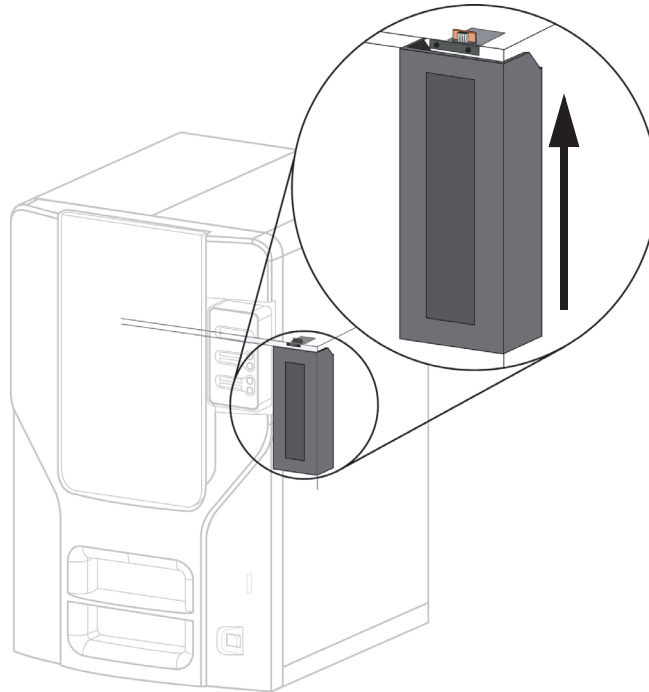

2. Pull the container towards you and out of the chamber.



Caution: When reinstalling the container, make sure that it locks on all three mounts and hangs flush with the chamber wall to avoid damage.

3. Empty the container and reinstall on 3 mounts.

500 HOUR MAINTENANCE

Preventive Maintenance Alerts will be displayed on the workstation at the 500 hour time interval as a reminder to perform preventive maintenance. See [Figure 5-3](#).

Figure 5-3: Preventive Maintenance Alert

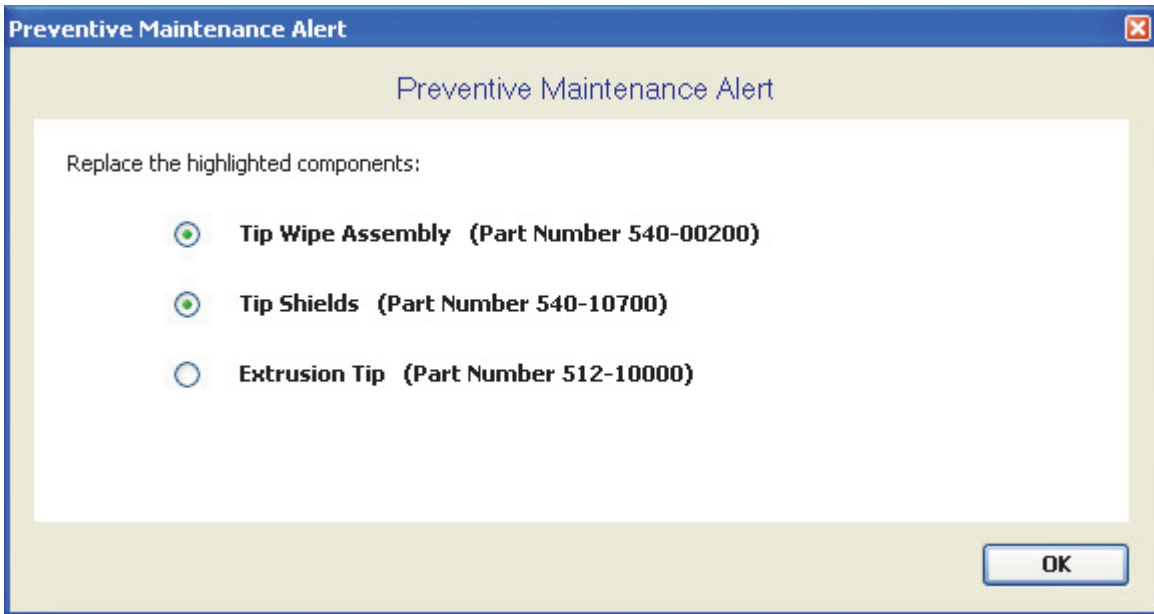

CLEAN FAN FILTER

To clean the fan filter:

1. Locate the lower fan on the rear panel of the system and remove the plastic frame (snaps on and off) that secures the fan filter. See [Figure 5-4](#).

Figure 5-4: Lower fan location

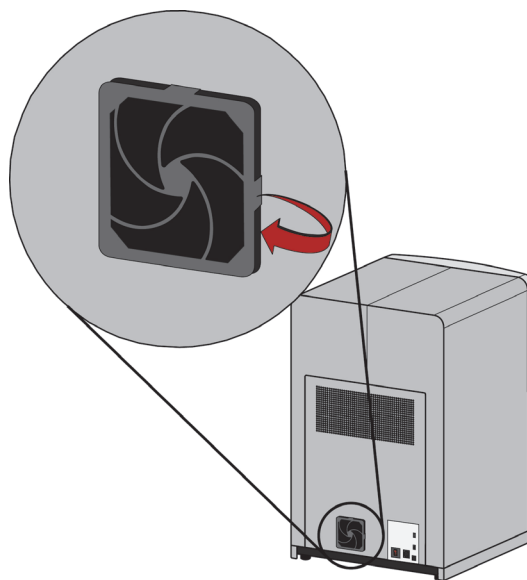

2. Clean the filter with soap and water, and blot it dry.
3. Reassemble.

REPLACE THE TIP WIPE ASSEMBLY



Note: The tip wipe assembly should be replaced after 500 hours, prior to performing Tip Cleaning Maintenance.

1. Completely power down the system. See “Powering Off” on page 35.
2. Move the Toggle Head to the left of the machine in order to gain access to the tip wipe assembly, see Figure 5-4.

Figure 5-5: Move the Toggle Head to the left

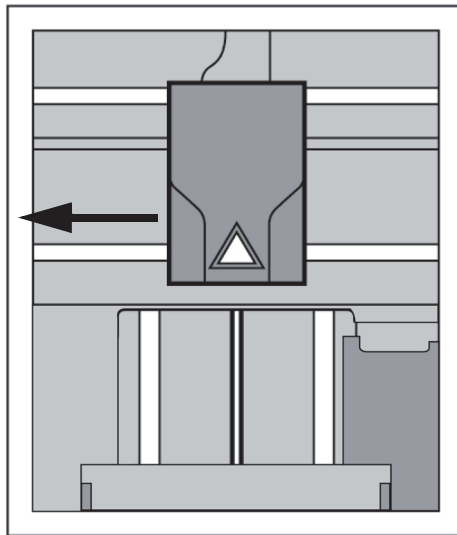

3. Remove the tip wipe assembly by lifting the assembly up and out of the machine. Discard the old tip wipe assembly, see Figure 5-5.

Figure 5-6: Replacing the tip wipe assembly

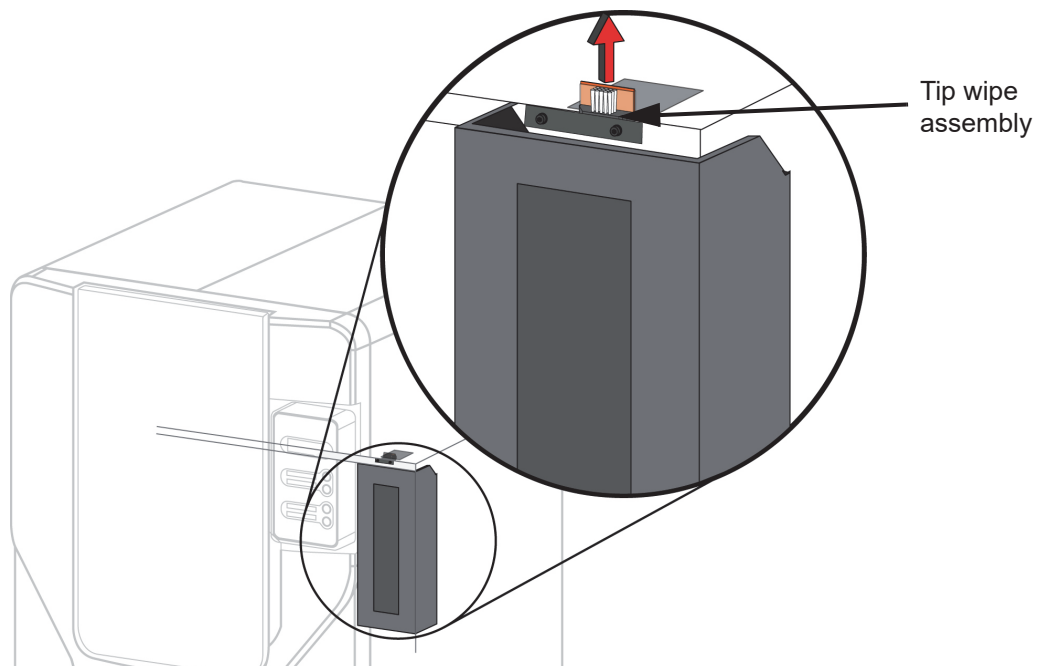

4. Place the new tip wipe assembly over the two mounting posts making sure the assembly is fully seated.

TIP SHIELD REPLACEMENT

Tip shields can become worn or damaged over time. This can have a negative impact on the surface finish and detail of models.

Figure 5-7: Tip shield damage

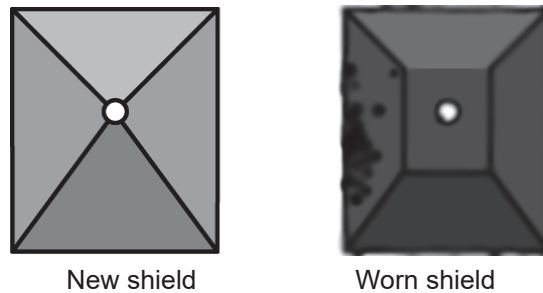

1. Enter **Head Maintenance**.
 - A. From the display panel press **Maintenance**.
 - B. Press **Machine**.
 - C. Press **Head**. The head will come to rest in the center of the chamber and the Z platform will change position.



Gloves: The head area is hot, wear gloves when working in this area of the system.

2. Remove the head cover by pressing the tabs in and pulling away from the head. See [Figure 5-8](#).

Figure 5-8: Head cover tab locations

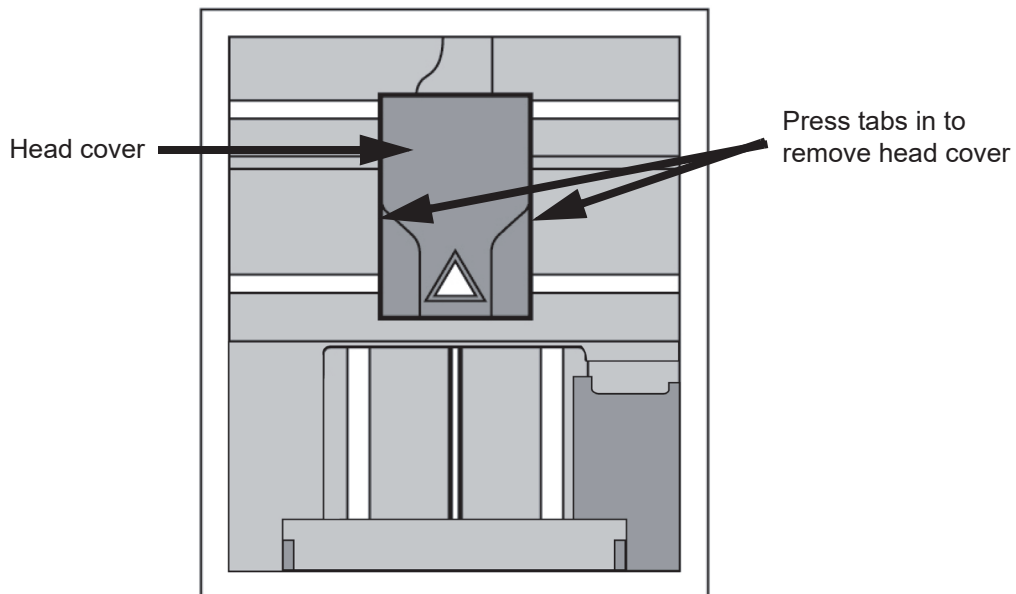

3. Position the blade of a small screwdriver between the tip shield and tip plate. Use the blade of the small screwdriver to separate the tip shield from the tip plate. See [Figure 5-9](#).

Figure 5-9: Tip shield removal

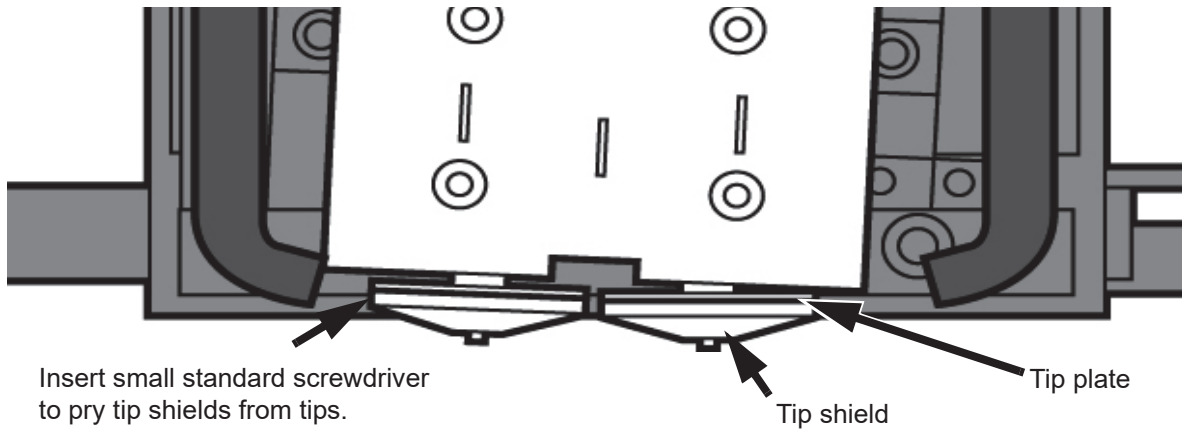

4. Clean the tip using the wire brush supplied with the Startup Kit to remove any debris. See [Figure 5-10](#).

Figure 5-10: Clean tips with wire brush

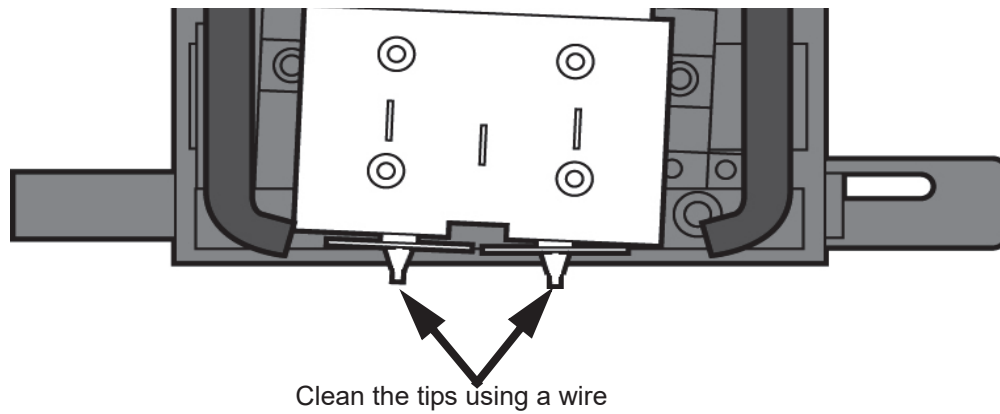

5. Install a new tip shield by pushing it over the exposed tip, keeping the slotted end toward the back of the head. See [Figure 5-11](#).



Note: Tip shield should be flush with the tip plate as shown in [Figure 5-12](#).

Figure 5-11: Tip shield installation

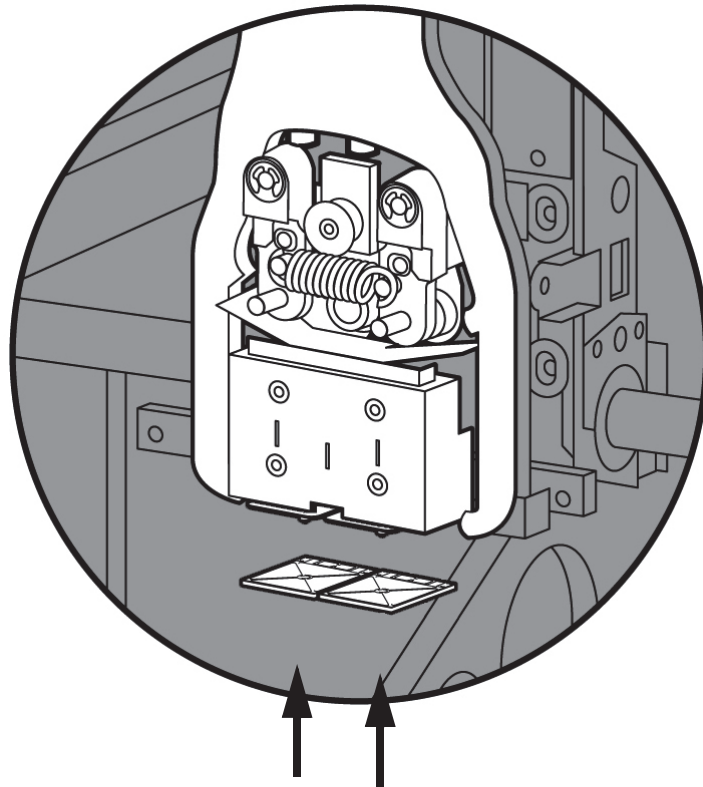
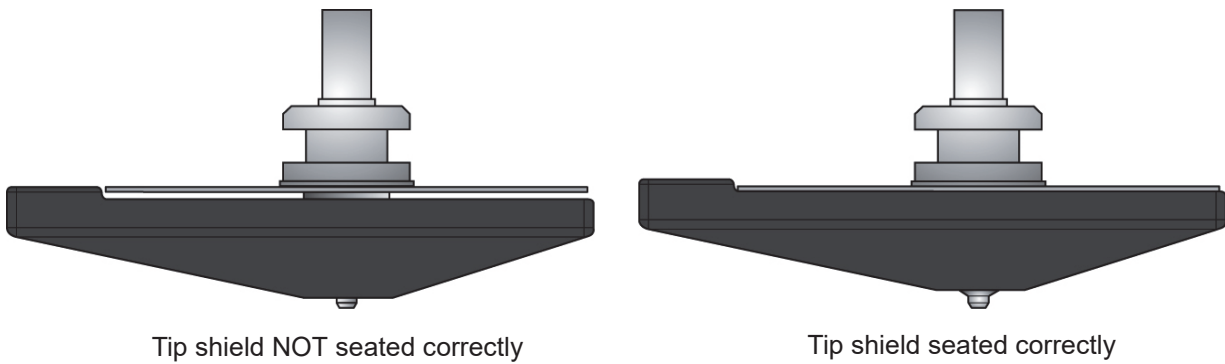

Figure 5-12: Tip shield placement



6. Replace head cover.



Note: If the head cover is not replaced the system may not function properly.

7. Exit **Maintenance**, press **Done** until back at **Idle**.

2000 HOUR MAINTENANCE

Preventive Maintenance Alerts will be displayed on the workstation at the 2000 hour time interval as a reminder to perform preventive maintenance. See [Figure 5-13](#).

Figure 5-13: Preventive Maintenance Alert

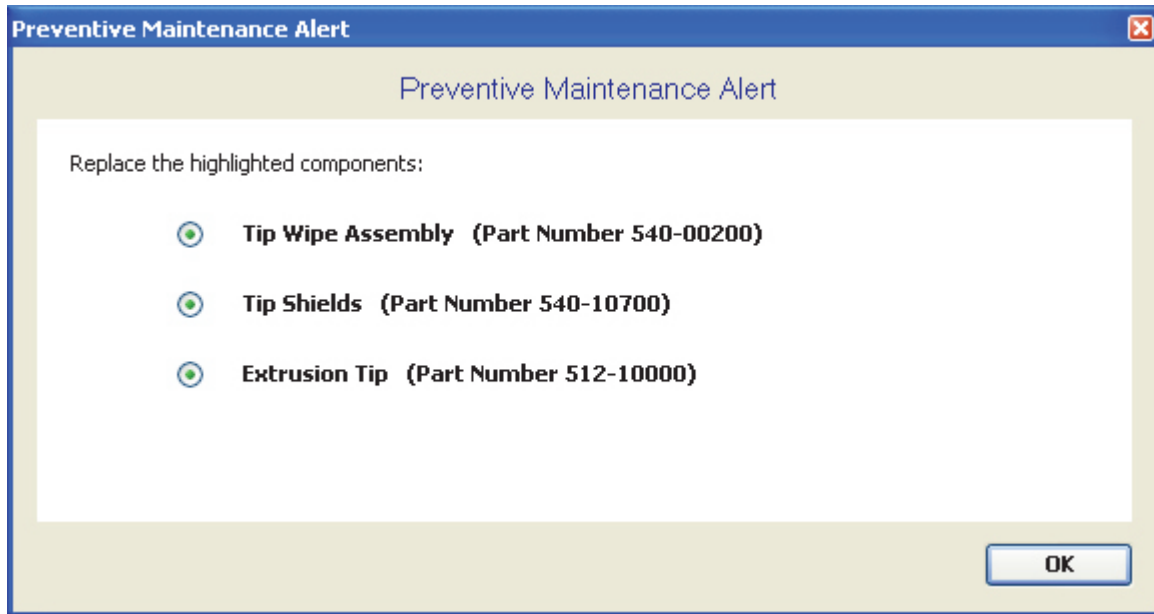

LIQUEFIER TIP REPLACEMENT

Replace tips at approximately 2000 hours - depending upon operating conditions. Tips can also be damaged by improper care while performing maintenance in the area around the tips.



Note: Control Center displays the tip time (hrs) - from the Services Tab - System Info button (Tip time will reset to zero after replacement).

REMOVING TIPS

1. You will need to make sure the system is powered ON before replacing the extrusion tip.
2. From the display panel press **Maintenance**.
3. Press **Machine**.
4. Press **Tip**.
5. Press **Replace**.
6. The system will display **Material Unload - Unloading Model**.
7. When unload is complete, display will prompt to remove the material cartridges.
8. You can now open the system door and replace the tips - or you can **Cancel** the tip replacement procedure.
9. Remove plastic head cover by squeezing raised pads on sides of cover. See [Figure 5-14](#).

[Figure 5-14](#): Removing the Head Cover

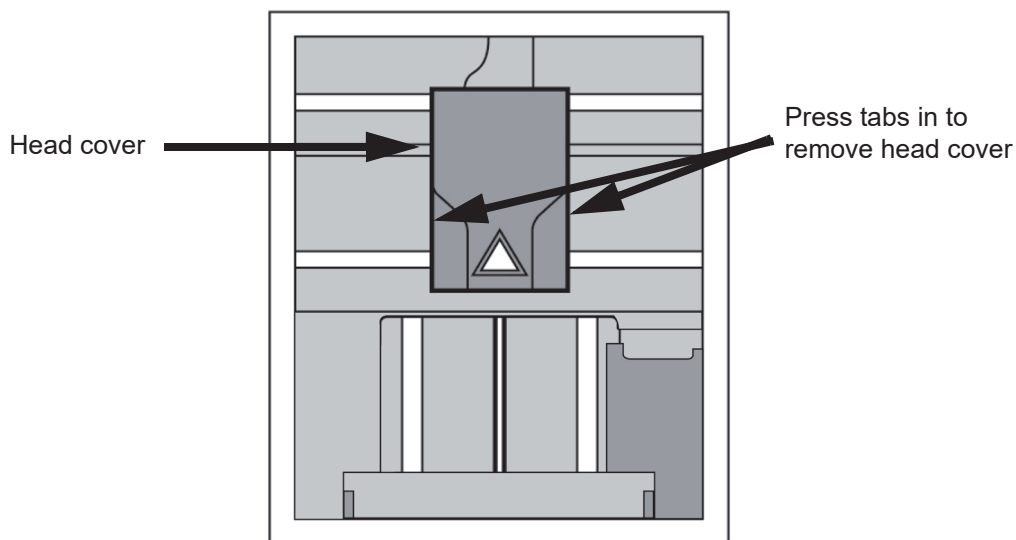

10. Remove Tips:

- A. Use $\frac{7}{64}$ " T-Handle Allen wrench to loosen the heater block screws three to four full turns counterclockwise - or until the top of the screws are flush with the metal cover. **DO NOT** remove the screws entirely. See [Figure 5-15](#).

[Figure 5-15](#): Tip removal

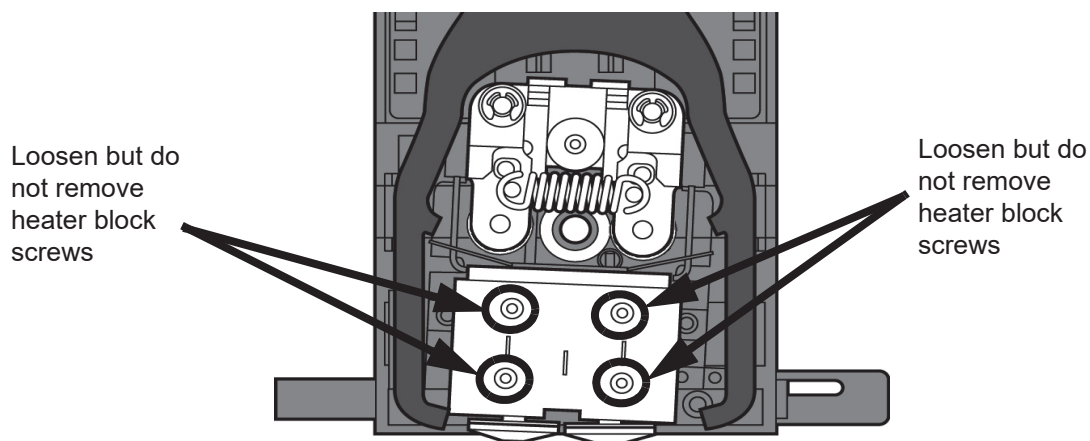

- B. Use needle nose pliers to grasp the stainless steel shield of the tip.
- C. Pull the tip shield toward you, then pull down to remove the tip from the heater block. Discard the used tip. See [Figure 5-16](#).

Figure 5-16: Remove the tips

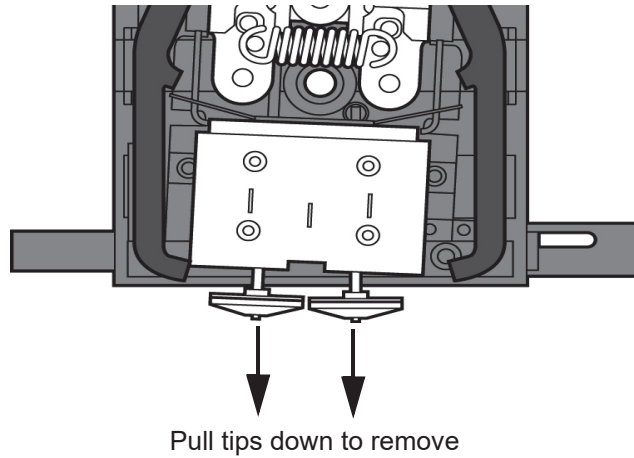

- D. Repeat for second tip if necessary.

INSTALLING TIPS

1. You must identify the correct replacement tip. The Fortus 250mc uses two tip types. You must make sure a SUPPORT tip is used on the LEFT side of the head assembly. A MODEL tip must be used on the RIGHT side of the head assembly (see [Figure 5-17](#)). The Model tip comes in a red capped container. The Support tip comes in a black capped container.



Caution: Model and support tips are different. The correct tip must be installed in the correct side.

Figure 5-17: Identifying Tips

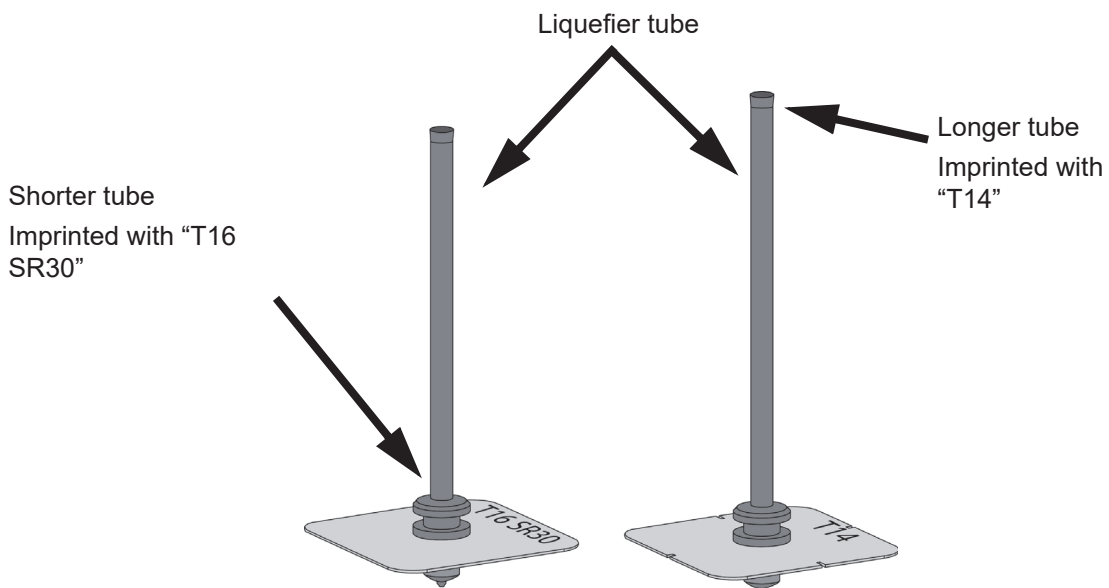

2. With gloved hand, insert the new tip into the heater block.
3. Use needle nose pliers to grasp the stainless steel shield of the tip.
4. Pull the tip shield toward you, then lift up to install the tip.
5. Push the tip toward the back of the system once it is all the way up against the heater block.
6. Verify the tip is fully inserted into the heater block and that the stainless steel shield is aligned, see [Figure 5-18](#).
7. Use $\frac{7}{64}$ " T-Handle Allen wrench to firmly tighten the heater block clamp screws.



Note: Make sure Tip remains all the way up against the heater block as you tighten the screws.

Figure 5-18: Installation Examples

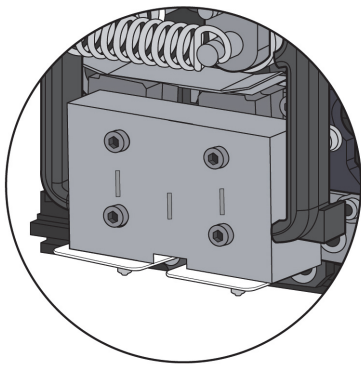

CORRECT

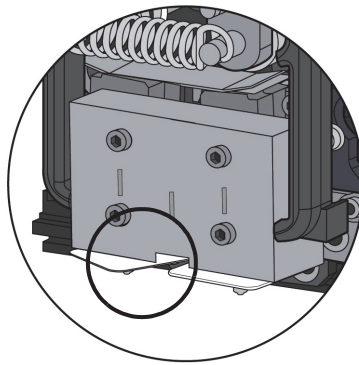

INCORRECT -
Shield interference

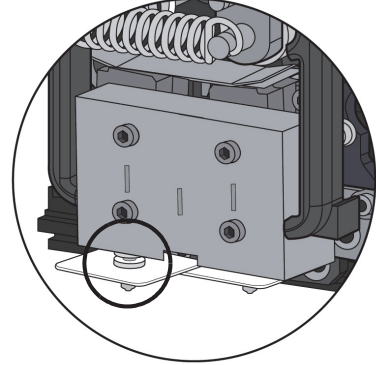

INCORRECT -
Tip not seated

8. Repeat steps 3 through 7 for second tip if necessary.
9. Install a new tip shield by pushing it over the exposed tip, keeping the slotted end toward the back of the head. See [Figure 5-19](#).



Note: Tip shield should be flush with the tip plate as shown in [Figure 5-20](#).

Figure 5-19: Tip shield installation

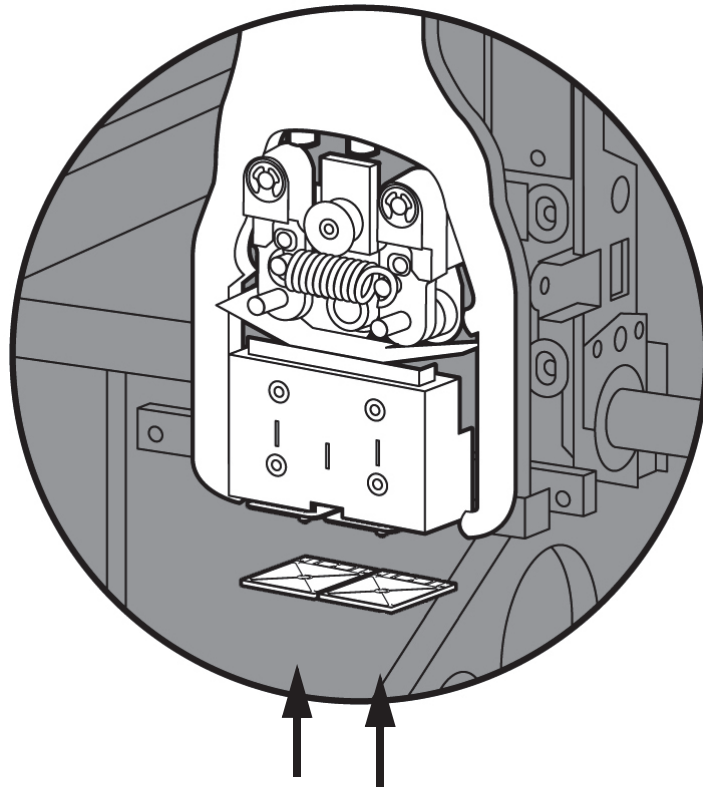
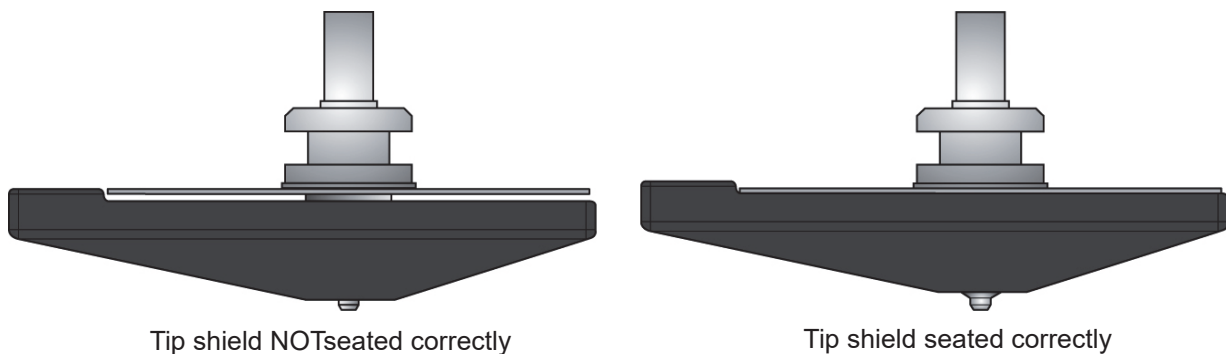

Figure 5-20: Tip shield placement



10. Replace head cover.



Note: If the head cover is not replaced the system may not function properly.

11. Close the system door.

12. The system will display **Tip Maintenance - Tips Replaced?** - select **Yes** to begin material load.

A. The system will display **Maintenance - Add/Remove** (flashing).

- If you want to replace a material cartridge, do so now (See [“Loading Material” on page 30](#)).

B. Load the model and support material cartridges by pushing in until they latch. Press the **Load Selected** button.

C. The system will now begin to load material. See [“Loading Material” on page 30](#).

- D. After Material Loading is complete the system will display **Calibration - Install Modeling Base And Build Cal Part.**



Caution: Make sure a NEW, UNUSED modeling base is installed before starting calibration. Calibration results will be incorrect if a previously used modeling base is installed.

TIP CALIBRATION

Tip replacement requires Tip Calibration.

1. Select **Start Part** (flashing) - the system will run two calibration parts.
 - The system will automatically build a Z Calibration part, measure the part and calibrate the Z Axis for tip depth and tip level (approximately 5 minutes). The Z calibration is automatic.
 - The system will then automatically build an XY Calibration part (approximately 10 minutes). You must inspect the XY Calibration part and calibrate the X and Y axis for tip offset:
2. When the XY Calibration part is complete the system will display **Remove Part and Select XY Adjustment - X:0, Y:0**
3. Remove the XY tip calibration part from the system.
4. Inspect the part and calibrate the X and Y axis, see [Figure 5-21](#).
 - A. Use the magnifier from the Startup kit to view the support road (shown in red).
 - B. Identify the location on the +X or -X side of the part where the support road is best centered within the model boundaries (shown in blue).
 - C. Read the number closest to this location. This is the required X Tip Offset adjustment. If the number is on the -X side, a negative offset is required.
 - D. Select **Increment** or **Decrement** to input the X offset adjustment - the value will change in the upper display window (by default, the system will be ready to accept the X value).
 - E. When you are satisfied with your X offset value, **Select Y** and repeat steps A- D to identify and input the required Y Tip Offset adjustment.

Figure 5-21: Example XY Tip Offset Part.

This example requires an adjustment of X = + 2, Y = - 4

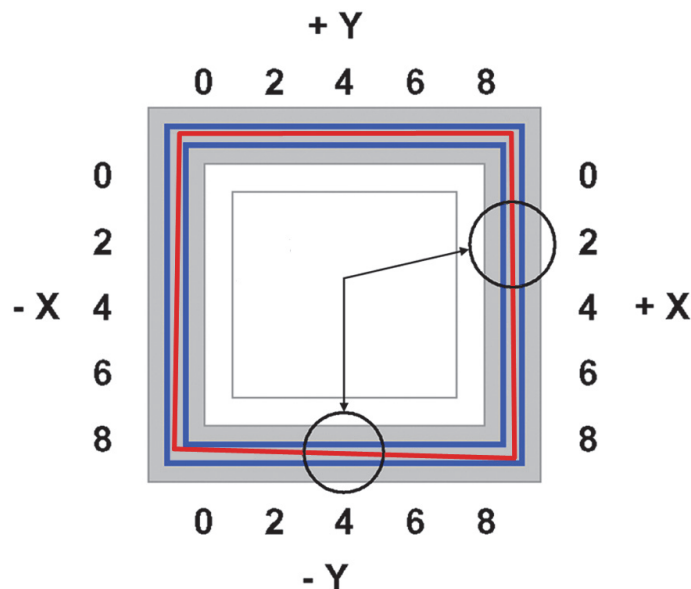

5. Select **Done** after you have input the X and Y offsets. The system will return to **Maintenance**. Run the XY calibration a second time to be sure the values changed the offset properly.
6. When finished, press **Done** until back at **Idle**.

AS NEEDED MAINTENANCE

The following maintenance items have no routine schedule but should be tended to as needed.

CHAMBER LIGHT BAR



ESD Sensitive!

ESD: Use proper ESD grounding techniques when handling electronic components.



Caution: Use only a factory authorized replacement light bar.

Replace a chamber light bar when it burns out.



Note: There are two light bars in the modeling chamber. They are located on the front wall of the chamber - one to the right, the other to the left of the chamber door.

REPLACE CHAMBER LIGHT BAR

1. Power down the system.
2. Locate the wiring harness leading away from the bottom of the light bar.
3. Disconnect the light bar from the wiring harness by squeezing the wiring harness clip while pulling down.
4. Remove the light bar by removing the 3 attachment screws (top, middle, bottom) - use the $\frac{7}{64}$ " T-handle wrench supplied in the Startup Kit.
5. Install a replacement light bar with the 3 attachment screws - do not overtighten the screws.
6. Re-attach the wiring harness lead.

6 TROUBLESHOOTING

TROUBLESHOOTING CHECKLIST

Problem or error message	Solution
No power	<ol style="list-style-type: none">1. Verify power cord is securely plugged in.2. Verify that the circuit breaker (at rear of system) and the power switch (on front panel of system) are both in the ON position.3. Verify AC power is present at wall outlet.
System fails to reach operating temperatures	Verify the system is not connected to an extension cord or power strip.
Material not extruding	Material may be jammed in extrusion head, see “Recovering from loss of extrusion” on page 59.
Model/Support Jam in head clear before resuming	See “Material Jam” on page 57.
Purge material accumulating on part.	<ol style="list-style-type: none">1. Material may have accumulated behind tips. See “500 Hour Maintenance” on page 41.2. Make sure that the tip wipe assembly is set to the proper height. See “Replace the tip wipe assembly” on page 42.3. Check condition of tip wipe assembly. Replace if worn. See “Replace the tip wipe assembly” on page 42.
No text displayed on Display Panel	Cycle power (see “Cycling power” on page 55.)
Cannot communicate with system through network	<ol style="list-style-type: none">1. Make sure network cables are connected - at the system, at the PC, and where cables connect to network boxes.2. Re-configure settings per, see “Networking the system” on page 12.3. If using a Static network address, verify that the IP address entered in Control Center has the same value as the address entered for the system.4. Your system configuration may have changed. Contact your Network Administrator.
Error Code displayed on Display Panel	Call your local reseller for customer support. For more information, refer to “Fault determination codes” on page 54.
Display Panel displays Build Error	Partial or bad part file sent to system. Check STL file validity in CAD software; reprocess STL in Insight and redownload to system.
Display Panel displays Can’t Find Home – Check Modeling Base	<ol style="list-style-type: none">1. Verify a modeling base is inserted.2. Modeling base may be used or defective – replace.
Display Panel displays Communication lost at HR:MN UCT	The system stopped reporting its status at the Universal Coordinated Time (UCT) shown. Wait for the system to complete building the part. The system will automatically restart and display Build Complete. It is then safe to remove the model.

Problem or error message	Solution
Display Panel displays Could Not Read Cartridge	<ol style="list-style-type: none"> 1. Remove cartridge and cycle power, see “Cycling power” on page 55; reload cartridge. 2. Try a different cartridge.
Display Panel displays Load Failed	<ol style="list-style-type: none"> 1. Retry with same cartridge. 2. Try a different cartridge. 3. Material may be jammed in extrusion head, see “Material Jam” on page 57. 4. Tips may be partially clogged. See “Clogged tip” on page 56.

FAULT DETERMINATION CODES

If a fault occurs which would prevent the system from executing an operator request, the system will begin to shut down and cool. The panel will display an error code. An error-code list (with the filename “error.txt”) can be found on the CD-ROM for the system software. (Because this list may change with each new software version, be sure to check the error.txt attachment when you install new system software upgrades.)

After the system has finished cooling, the only option displayed is **Continue**. Press **Continue** and the system will reboot and try to return to normal operation. If pressing **Continue** does not eliminate the error, power should be cycled (see [“Cycling power” on page 55](#).); wait 60 seconds before switching power on again. In most cases you will be able to continue operation. However, if the system continues to shut down and display the same error, contact your Reseller for customer support.

EXPORTING SYSTEM CONFIGURATION (.CFG) FILE

If your system is receiving fault determination codes, you may need to export a configuration (.cfg) file from your system to send to your Reseller for customer support.

EXPORTING CONFIGURATION FILE FROM THE SYSTEM

1. Open Control Center from your workstation.
2. Click on the **Services** tab.
3. Click on the **Export Configuration** button.
4. Browse to the directory where you wish to save the configuration file.
5. Click on the **Save** button.
6. Close Control Center.

CYCLING POWER

1. Turn the power switch to the OFF position. The display will show **Shutting Down**.
2. After the system has cooled down enough to shut down, the display will go blank.
3. When the display is blank and the system has shut down, turn the circuit breaker to the OFF position.
4. Once the circuit breaker has been turned to the OFF position, wait 60 seconds and turn the circuit breaker back to the ON position.
5. Turn the power switch to the ON position. The system display will show that it is starting up.

Once the display shows **Idle** or **Ready to Print**, you can send a file to the system to be printed.

DIAGNOSING LOSS OF EXTRUSION

Occasionally, the system's head may experience loss of extrusion. This will be evident by observing one of the following:

- The head is moving with no material coming out of either tip.
- The height of the model and support materials are not equal.
- Sagging structures due to lack of support materials.



Gloves: The head area is hot. Use gloves when working in this area of system.

1. From the display panel press **Cancel** and remove parts from the system.
2. Insert a new modeling base.
3. From **Idle**, press **Maintenance**.
4. Press **Machine**.
5. Press **Head**. The head will move to the center of the chamber and the Z platform will change position. The display will read: **Model Drive Motor Stopped**.
6. Determine if there is a model material extrusion problem by pressing **Forward** (command will be available after head reaches operating temperature). Watch the model tip (right tip) for any extrusion (material purge).



Note: You may need to wait up to 30 seconds before extrusion will begin as the tip may need to reach operating temperature.

7. Press **Stop** to stop the extrusion.
8. If material did NOT flow from the model tip, see [“Recovering from loss of extrusion” on page 59](#). If material steadily flowed from the model tip, the model tip is functioning properly.
9. Test the support material tip by choosing: **Select Drive**.
10. Determine if there is a support material extrusion problem by pressing **Forward**. Watch the support tip (left tip) for any extrusion (material purge).
11. Press **Stop** to stop the extrusion.

12. If material did NOT flow from the support tip, see “[Recovering from loss of extrusion](#)” on page 59. If material steadily flowed from the support tip, the support tip is functioning properly.
13. Return the system to the Maintenance state - Press **Done**.
14. Display will ask **Which Materials Loaded?** Press **Both**.
15. Press **Done** until back at **Idle**.

CLOGGED TIP

Occasionally, a tip may clog with material. This will often result in a loss of extrusion (LOE). A clogged tip will prohibit material load and part building.

1. Remove the head cover by pressing the tabs in and pulling away from the head. See [Figure 6-1](#).



Gloves: The head area is hot. Use leather gloves when working in this area of system.

Figure 6-1: Remove the head cover

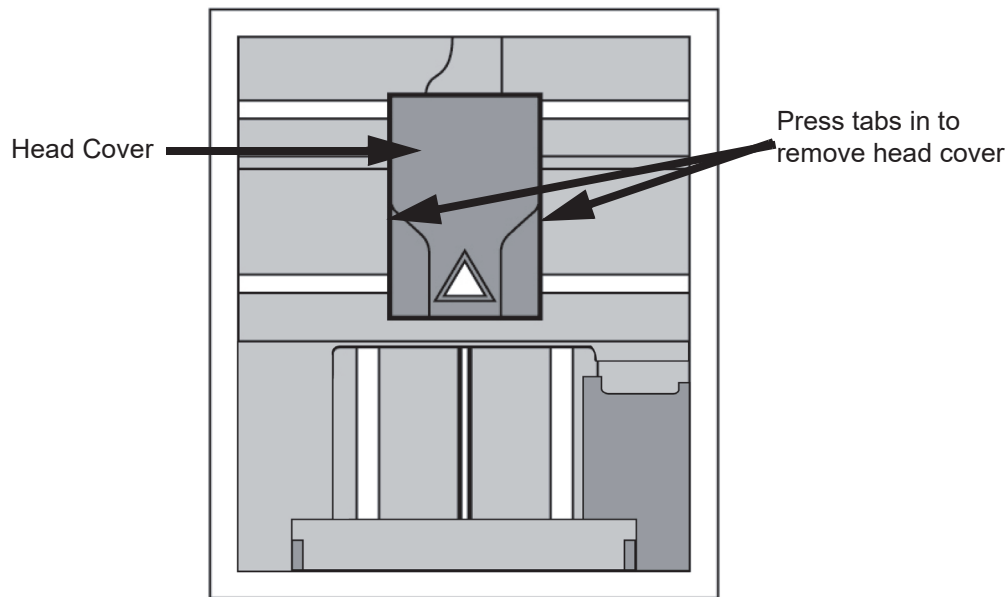

2. Inspect top of tips for material build up. If there is excess material build up see “[Recovering from loss of extrusion](#)” on page 59. If there is no excess material build up close the chamber door and continue.
3. From the display panel press **Maintenance**.
4. Press **Machine**. The system will calibrate which will take approximately 3 minutes.
5. Press **Head**. The head will heat up to operating temperature which will take approximately 3 minutes.
6. Press **Select Drive** and choose the drive that may have the clogged tip.
7. Press **Forward**, the drive wheel will turn the selected drive forward.

8. Press **Blower Off**, this will turn the head cooling fan off for 10 seconds, allowing the tip to heat up beyond operating temperature. If material starts to extrude the tip is no longer clogged. If material does not extrude see [“Recovering from loss of extrusion” on page 59.](#)
9. Press **Done**.
10. Replace head cover.



Note: If the head cover is not replaced the system may not function properly.

11. Display will ask **Which Materials Loaded?** Press **Model** if only model material is loaded, press **Support** if only support material is loaded or press **Both** if both model and support material are still loaded. Press **None** if neither are loaded.
12. Press **Done** until back to **Idle**.

MATERIAL JAM

Occasionally, material may become jammed in the head. The system will notify you of a material jam through a message shown on the display panel. If a material jam is detected, follow these steps to clear the jam.

1. From the display panel, press **Continue**.
2. Press **Maintenance**.
3. Press **Machine**.
4. Press **Head**.
5. Once in head maintenance mode, remove the head cover by pressing the tabs in and pulling away from the head. See [Figure 6-2](#).



Gloves: The head area is hot. Use leather gloves when working in this area of system.

Figure 6-2: Remove the head cover

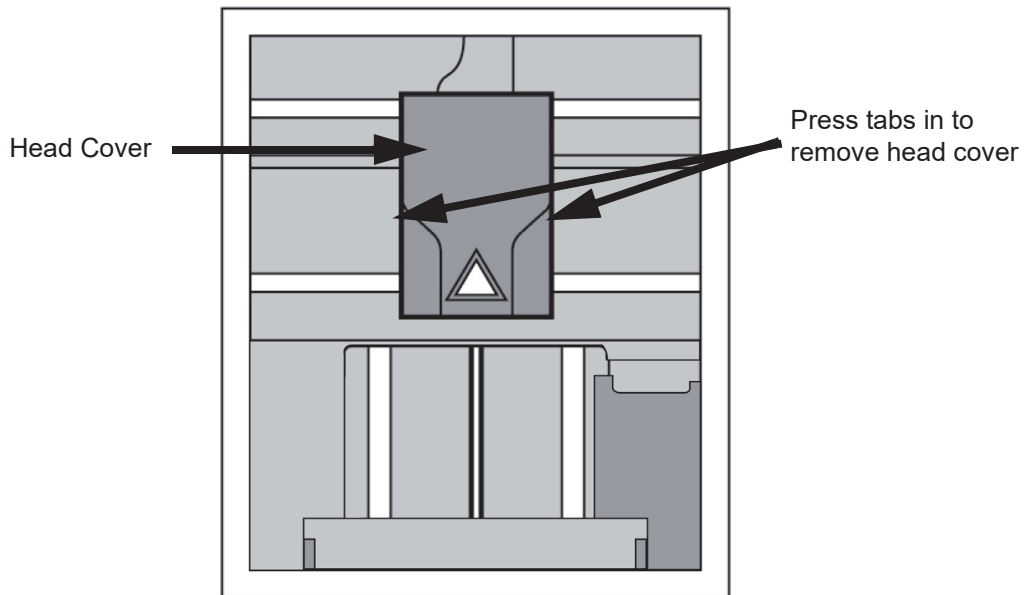

6. Inspect tip inlets for material build up see [Figure 6-3](#). If there is excess material build up see [“Recovering from loss of extrusion”](#) on page 59. If there is no excess material build up close the chamber door and continue.

Figure 6-3: Tip inlet locations

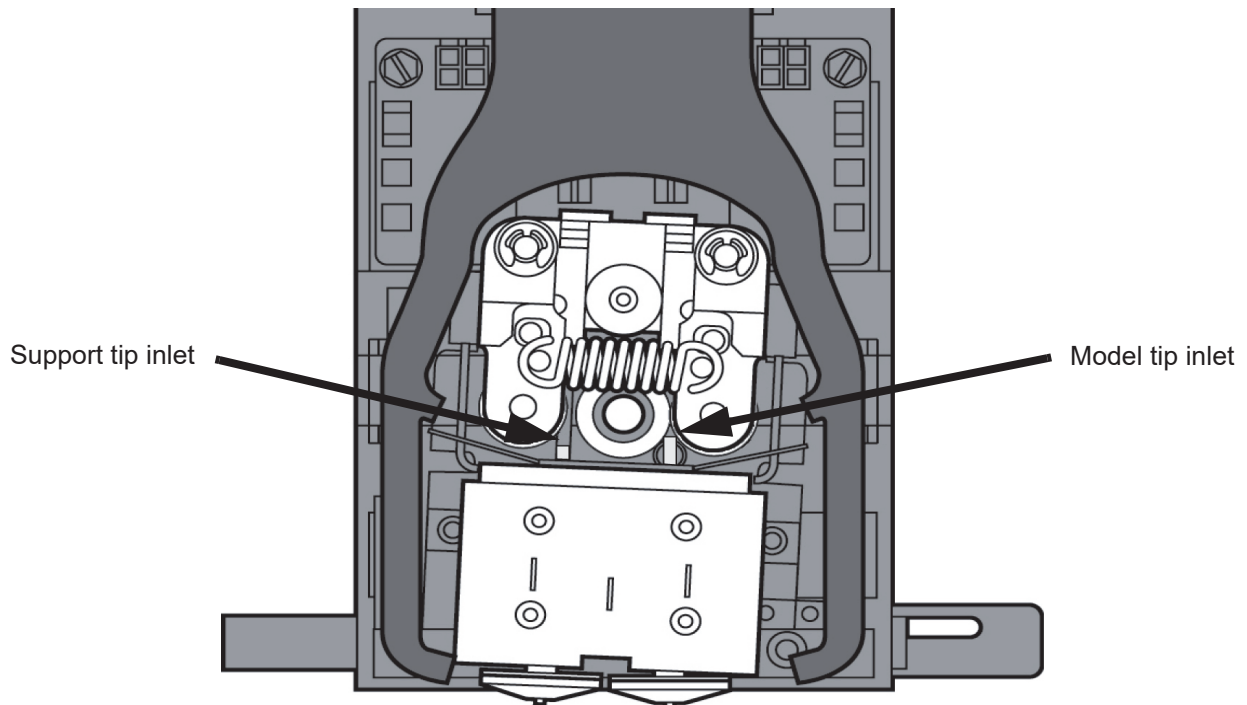

7. Press **Select Drive** and choose the drive that may have the clogged tip.
8. Press **Forward**, the drive wheel will turn the selected drive forward.
9. Press **Blower Off**, this will turn the head cooling fan off for 10 seconds, allowing the tip to heat up beyond operating temperature. If material starts to extrude the tip is no longer clogged. If material does not extrude see [“Recovering from loss of extrusion”](#) on page 59. If material extrudes, you can continue building your part.

10. Reinstall the head cover.



Note: If the head cover is not replaced the system may not function properly.

11. Press **Done**.

12. Display will ask **Which Materials Loaded?** Press **Both**.

13. Press **Done** until back to **Pause** screen.

14. Press **Resume** to continue building the part.

RECOVERING FROM LOSS OF EXTRUSION



Note: It is recommended that you read and understand this entire procedure before performing any of the work.

1. Enter **Head Maintenance** mode.

A. From **Idle**, press **Maintenance**.

B. Press **Machine**.

C. Press **Head**. The head will heat up to operating temperature which will take approximately 3 minutes.



Gloves: The head area is hot. Use leather gloves when working in this area of system.

2. Remove the head cover by pressing the tabs in and pulling away from the head. See [Figure 6-4](#).

Figure 6-4: Remove the head cover

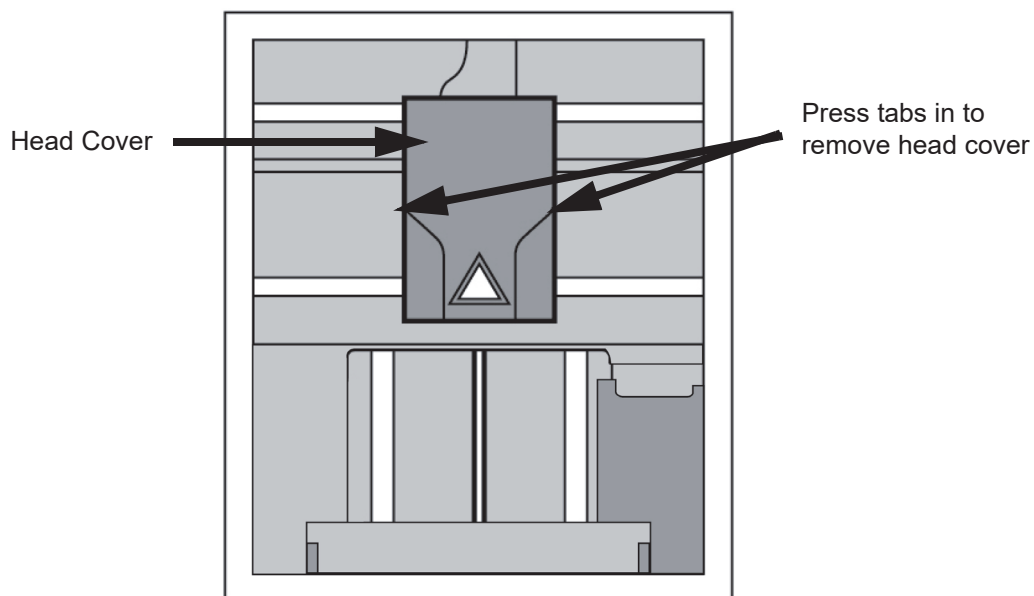

3. Place the toggle bar in neutral position (bar will extend equally from both sides of head). This can be done manually - push on the extended bar end. See [Figure 6-5](#).

[Figure 6-5](#): Head Components

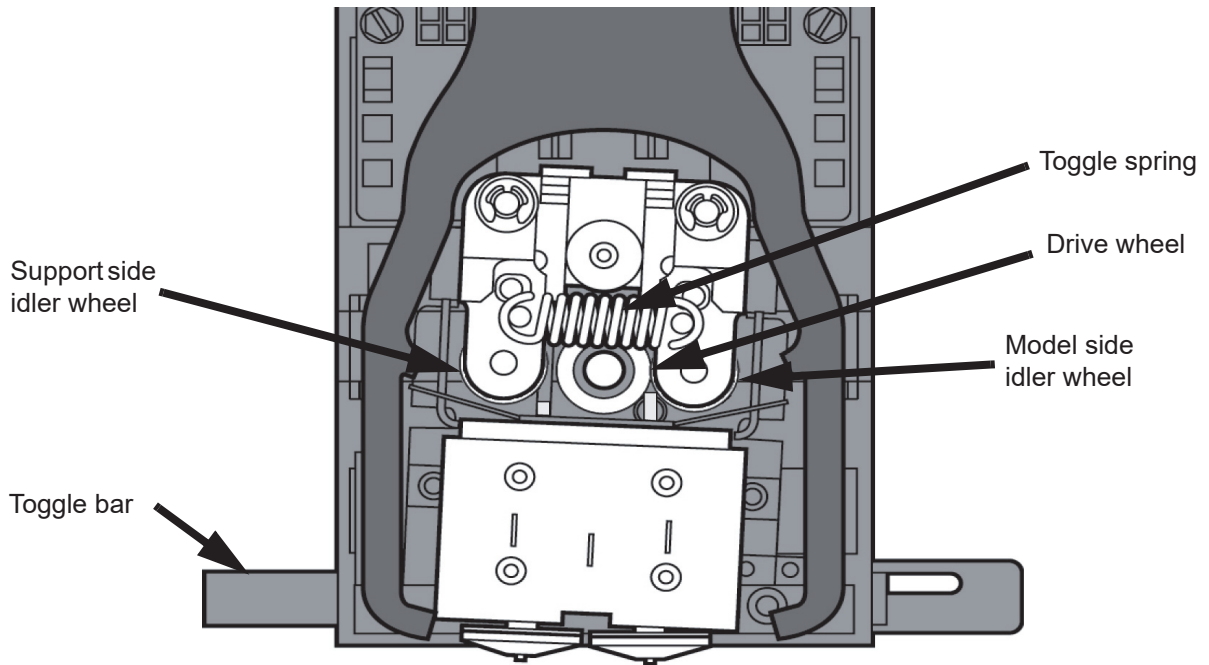

[Figure 6-6](#): Toggle bar in neutral position

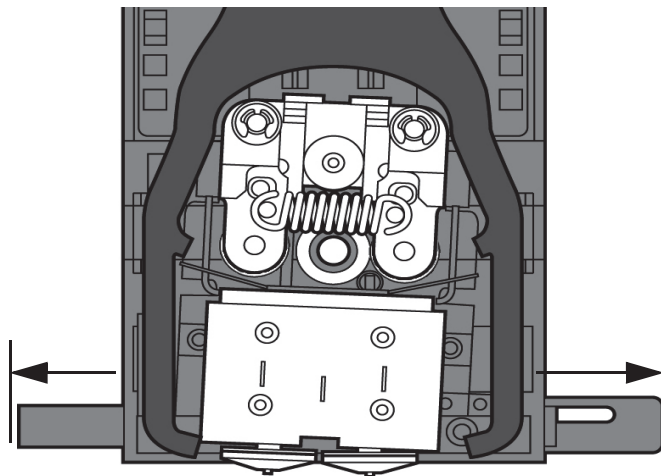

4. Remove any excess material found around the head area.



Note: Material fed to the tip can sometimes jam causing a build-up of material under the head cover.

- A. Clean out as much of the material as possible using needle nose pliers, a probe, or equivalent tool.



Caution: The end of the tip where the material enters is called the extrusion tube. Extrusion tubes are fragile. Use care when working in this area so as to avoid damage to the tubes.

- B. For easier access to areas that may need to be cleaned, move the material idler wheels out of the way (there is one idler wheel for support material and one for model material, see Figure 6-5).



Note: Move only one idler wheel assembly at a time. Finish cleaning around the moved wheel and restore it to its normal position before moving the other idler wheel. Having both wheels out of position simultaneously could stretch the spring.

- i. Place a $\frac{7}{64}$ " T-Handle Allen wrench between the toggle spring post and the idler wheel post as illustrated in Figure 6-7 (model side shown).
- ii. Position toggle bar to the same side of the head as the T-Handle allen wrench. See Figure 6-7 (model side shown).

Figure 6-7: Create access space for cleaning - model side shown

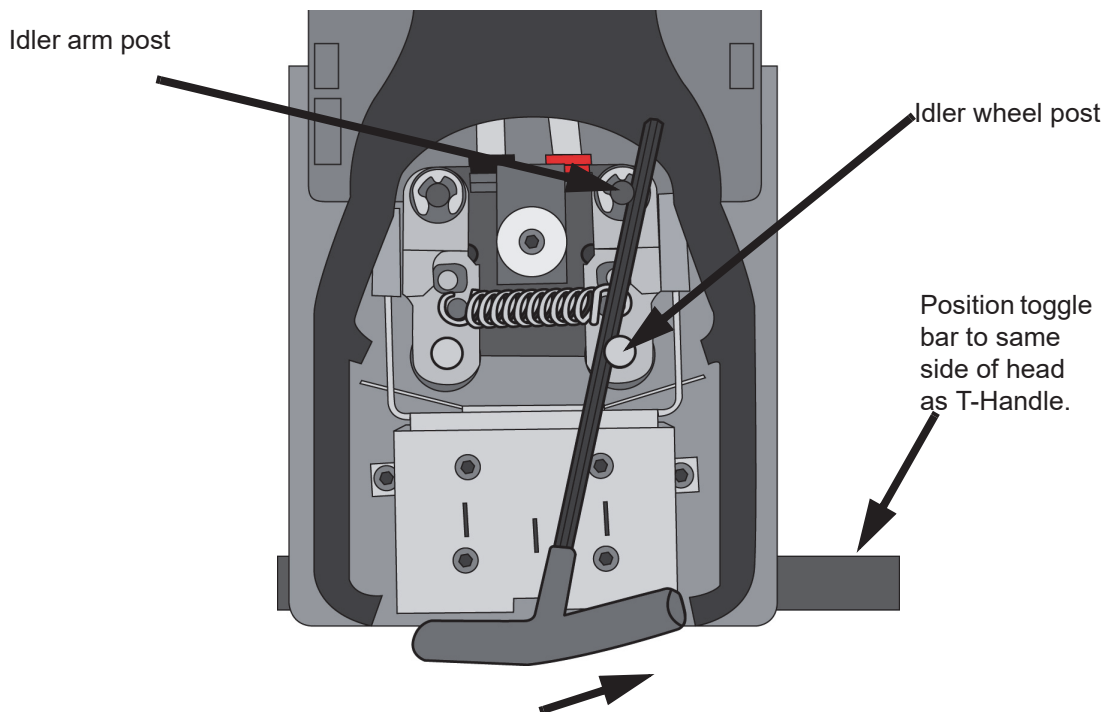

- iii. Move idler wheel assembly by pushing with $\frac{7}{64}$ " T-Handle Allen wrench against spring tension. Insert a $\frac{1}{8}$ " T-handled Allen wrench (from startup kit) into the fixture hole. See [Figure 6-8](#).

Figure 6-8: Holding access space open - model side shown

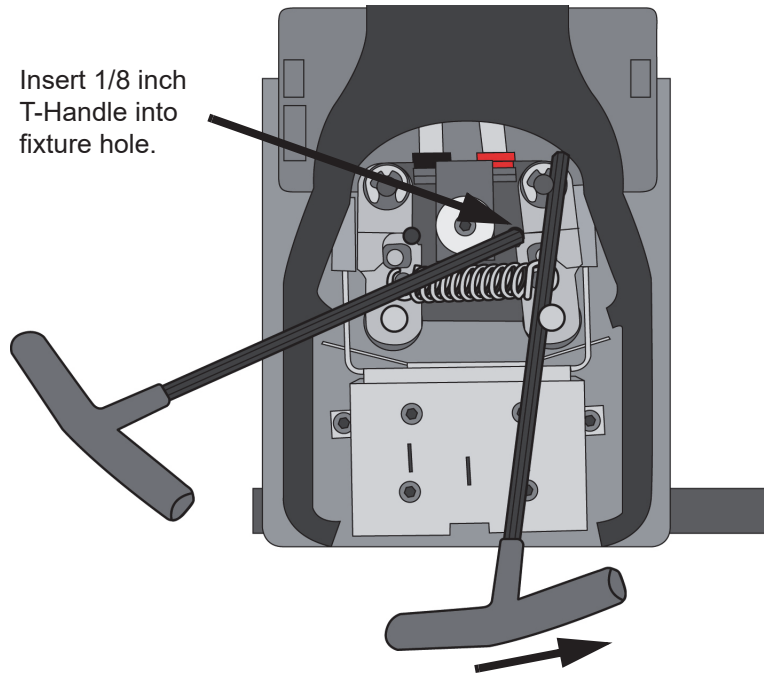

- iv. Ease pressure on the $\frac{7}{64}$ " T-Handle Allen wrench to carefully return the leveraged idler wheel back toward its original position - until the idler assembly is resting against the $\frac{1}{8}$ " T-Handle Allen wrench.
 - v. Remove the $\frac{7}{64}$ " T-Handle Allen wrench.
- C. Cut the material above the idler wheel using a cutters.
 - D. Clean the area that is now accessible using a needle nose pliers, a probe or equivalent tool.



Note: Make sure that all loose material is removed from the affected area.

- E. Reposition the $\frac{7}{64}$ " T-Handle Allen wrench between the toggle spring post and the idler wheel post.
- F. Move idler wheel assembly by pushing with $\frac{7}{64}$ " T-Handle Allen wrench against spring tension and remove the $\frac{1}{8}$ " T-handled Allen wrench.
- G. Remove the $\frac{7}{64}$ " T-Handle Allen wrench.

5. Repeat for the opposite side as needed.
6. Replace the head cover.



Note: If the head cover is not replaced the system may not function properly.

7. Press **Done** on the display panel.
8. Display will ask **Which Materials Loaded?** Press **Model** if only model material is loaded, press **Support** if only support material is loaded or press **Both** if both model and support material are still loaded. Press **None** if neither are loaded.
9. Display will ask you to remove the cartridge of the materials that are not loaded. Remove the cartridge and cut the excess material.
10. Press **Done** until back at **Idle**.
11. Reload the material that is not loaded.

7 SUPPORT

CUSTOMER SUPPORT

Contact your local reseller for customer support.

When contacting your reseller please provide the following:

- Your name.
- Your telephone number.
- System model.
- System serial number.
- System software build number.
- Insight and Control Center version number.
- Detailed description of the problem you are experiencing.
- Please try to be near the printer for troubleshooting, if possible.

For advanced troubleshooting (provide by email):

- System CFG file.
- STL and/or CMB files.
- Detailed photographs showing the issue.

8 RECYCLING

Visit <http://www.stratasys.com/recycle> for recycling information on material cartridges.

RECYCLING CODES

System Component	Materials	Recycling Code
Modeling bases	ABS	

All packaging materials can be recycled per your local recycling guidelines.

9 PRINTER SPECIFICATIONS

PHYSICAL SPECIFICATIONS

Height	1143 mm (45 in)
Width	737 mm (29 in)
Depth	838 mm (33 in)
Weight	148 kg (326 lbs)

FACILITY SPECIFICATIONS

Installation location	Stable flat surface capable of holding 159 kg (350 lbs).
Power Requirements	100–240VAC ~ 12 - 7A 50/60Hz 1200W dedicated circuit within 2 m (80 in.) Do not use an extension cord or a power strip. Using these can possibly cause intermittent power issues.
Air Circulation	115 mm (4.5 in) minimum space behind printer for air circulation. 153 mm (6 in) minimum space around printer for air circulation.
Network Connection	Ethernet 10/100 Base T within 4m (14 ft).

WORKSTATION SPECIFICATIONS

For details, see the Insight Workstation Requirements document available from the Stratasys website.

POWER SPECIFICATIONS

Source (nominal)	100–240VAC ~ 15 - 7A 50/60Hz 1200W Do not use an extension cord or a power strip. Using these can possibly cause intermittent power issues.
------------------	--

ENVIRONMENTAL SPECIFICATIONS

Operating temperature range	18°C to 30°C (65°F to 86°F)
Relative humidity range	30 to 70 percent, non condensing
Altitude	Shall not exceed 6561.68 feet (2000 m)
Air quality	Air quality conditions with excessive solid particulates (conductive or non-conductive) may result in system damage. Air quality conditions in which airborne oils are allowed to accumulate on or within the printer can damage the plastic components.
Heat emission	1080 Watts = 3686 BTU/hr typical 1380 Watts = 4710 BTU/hr max

10 SUPPLEMENTAL INFORMATION

UNINTERRUPTIBLE POWER SUPPLY (UPS)

USE AND INSTALLATION

The intent of the Uninterruptible Power Supply (UPS) shutdown feature on Fortus systems is to prevent required maintenance and/or system damage by safely shutting the system down in the event of an uncontrolled loss of power. Whether an in-process build of a part will complete successfully is dependent on the battery life of the selected UPS and the duration of the power outage.

The user should select a UPS with the following specifications:

- Runtime minimum of 15 minutes at 1000W or 2000VA output (run times >15 minutes may be appropriate based on the typical duration of power outages at the site)
- Runtime minimum 8 minutes after low battery warning tripped.
- Peak output (minimum) of 1500W
- Dry contact (voltage free) interface for “On battery” and “Low battery” conditions
- Dry contact interface capable of carrying at least 100mA at 12VDC.

GENERAL INFORMATION

Refer to the UPS and I/O Module (if used) Installation and Operation Guides for instructions on installing the I/O module (if used) into the UPS unit as well as for connecting AC power to the UPS and Fortus system. While connecting the Fortus system power to the UPS will provide some protection against power outages, the Fortus system will shut down safely when “on battery” and “low battery” conditions are detected. Follow the Electrical Interface Connection information below.

1. Configure Normally Open dry contact relay I/Os of UPS as shown in [Figure 10-1](#) (Wired-And configuration).
2. Build an appropriate length of UPS to Fortus system cable. See [Figure 10-2](#) for pin out.
3. Connect the cable from the UPS unit’s connector to the UPS (9-pin DSub) connector on the rear of the Fortus system.



Note: Make certain to install the jackscrews that hold the cable connectors to their respective mates (do not over-tighten)

4. Follow the instructions in the UPS Installation and Operation Guide to set the “Low Battery Warning Level” to 8 minutes.



Note: The default low battery warning level value may not provide adequate time to ensure the Fortus system can shut down safely.

Figure 10-1: Wired-And configuration

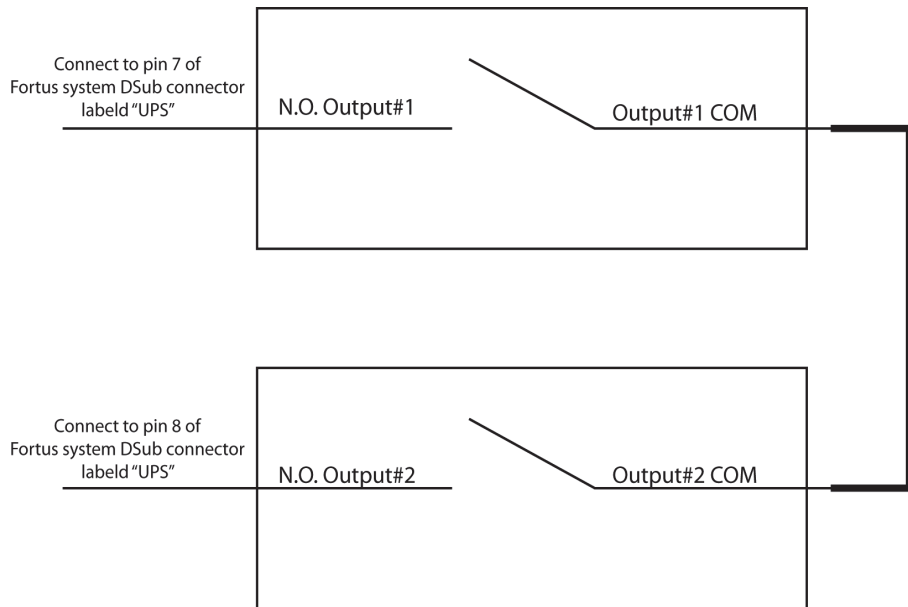

PARTS LIST – CABLE, UPS TO FORTUS SYSTEM

Item	Qty	Nomenclature / Description	Material Specification
1	1	Conn, Hsg, Plug, 9Pos	AMP - 205204-9
2	2*	Pin, Male, 24-20 AWG	AMP - 1-66506-0
3	1	Shell, Size 1, 9-Pin w/Grommets	AMP - 748677-1
4	2	Jackscrew Pair 4-40, Knurled	AMP - 747784-3
5	XX.x	Cable, 2 Conductor, 22 AWG	ALPHA - 1172C or Equivalent
6	3.0 inch	Sleeving, Heatshrink 1/4 Inch	3M - FP301 or Equivalent



Note: * May need additional pins depending on the UPS configuration.

Figure 10-2: UPS Cable Diagram

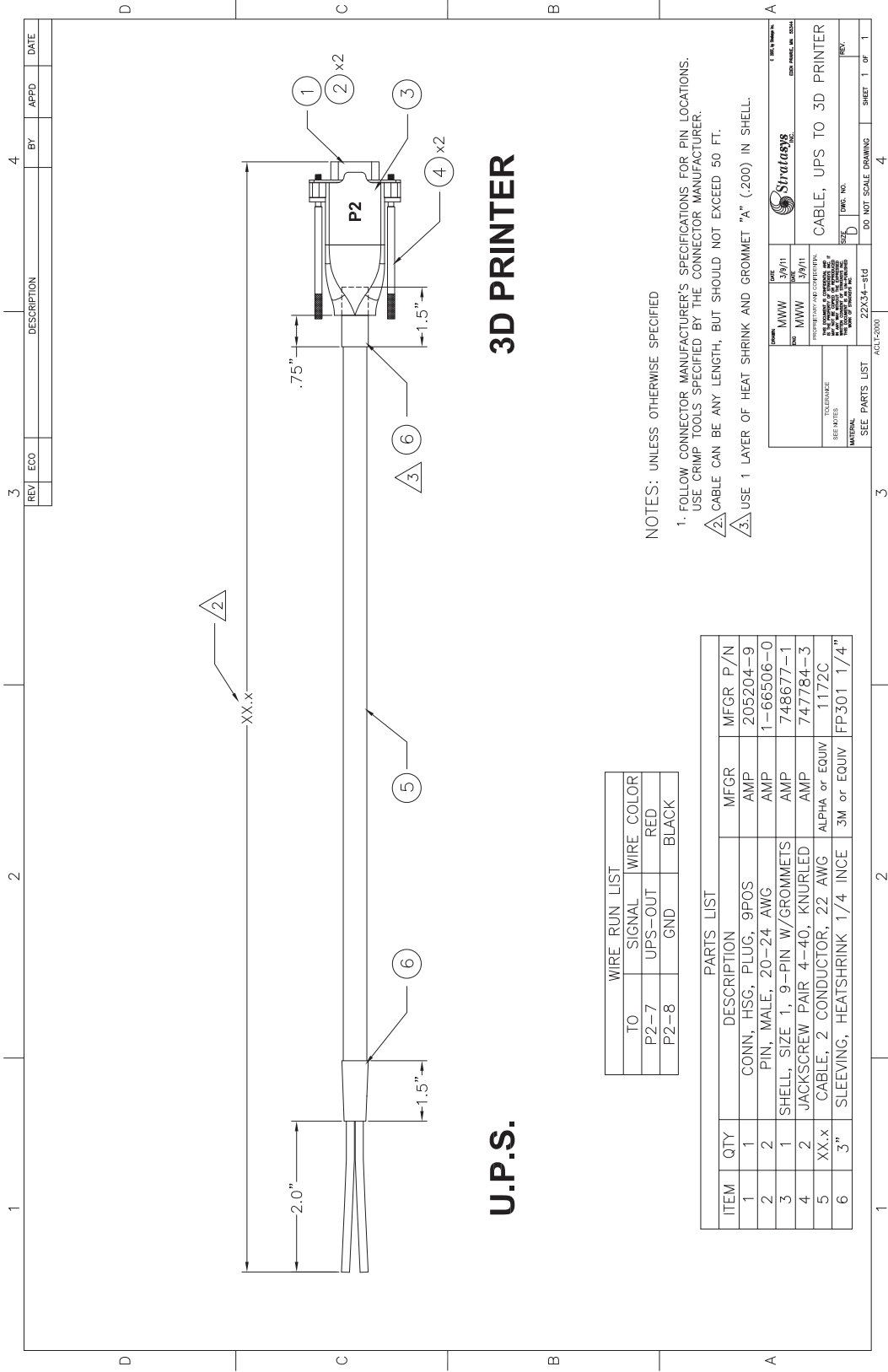

NOTES: UNLESS OTHERWISE SPECIFIED

1. FOLLOW CONNECTOR MANUFACTURER'S SPECIFICATIONS FOR PIN LOCATIONS. USE CRIMP TOOLS SPECIFIED BY THE CONNECTOR MANUFACTURER.
2. CABLE CAN BE ANY LENGTH, BUT SHOULD NOT EXCEED 50 FT.
3. USE 1 LAYER OF HEAT SHRINK AND GROMMET "A" (.200) IN SHELL.

WIRE RUN LIST	
TO	SIGNAL WIRE COLOR
P2-7	UPS-OUT RED
P2-8	GND BLACK

PARTS LIST			
ITEM	QTY	DESCRIPTION	MFGR P/N
1	1	CONN, HSG, PLUG, 9POS	AMP 205204-9
2	2	PIN, MALE, 20-24 AWG	AMP 1-66506-0
3	1	SHELL, SIZE 1, 9-PIN W/GROMMETS	AMP 748677-1
4	2	JACKSCREW PAIR 4-40, KNURLED	AMP 747784-3
5	XX.x	CABLE, 2 CONDUCTOR, 22 AWG	ALPHA or EQUIV 1172C
6	3"	SLEEVING, HEATSHRINK 1/4 INCE	3M or EQUIV FP301 1/4"

DATE	3/9/11	BY	3/9/11
DESIGNED BY	MWW	CHECKED BY	MWW
PREPARED BY OR CONSULTED BY: SEE NOTES MATERIAL: SEE PARTS LIST			
TITLE: CABLE, UPS TO 3D PRINTER		DWG. NO.: 22X34-31d	
SHEET: 1 OF 1		DO NOT SCALE DRAWING	

DECLARATION OF CONFORMITY

Declaration of Conformity information is available from the Stratasys website at: <http://www.stratasys.com/customer-support/customer-resource-center/documentation>.

REGULATORY AND ENVIRONMENTAL INFORMATION

EMC CLASS A WARNING



Warning: This is a Class A product. In a domestic environment this product may cause radio interference in which case the user may be required to take adequate measures.

FCC STATEMENTS (U.S.A.)

The U.S. Federal Communications Commission (in 47 cfr1 5.105) has specified that the following notices be brought to the attention of users of this product.

This device complies with part 15 of the FCC rules. Operation is subject to the following two conditions:(1) this device may not cause harmful interference, and (2) this device must accept any interference received, including interference that may cause undesired operation.

Shielded cables: use of shielded data cables is required to comply with the Class A limits of Part 15 of the FCC Rules.



Caution: Pursuant to Part 15.21 of the FCC Rules, any changes or modifications to this equipment not expressly approved by Stratasys, Ltd. may cause harmful interference and void the FCC authorization to operate this equipment.



Note: This equipment has been tested and found to comply with the limits for a Class A digital device, pursuant to Part 15 of the FCC Rules. These limits are designed to provide reasonable protection against harmful interference in a commercial environment. This equipment generates, uses and can radiate radio frequency energy and, if not installed and used in accordance with the instructions, may cause harmful interference to radio communications. Operation of this equipment in a residential area is likely to cause harmful interference, in which case the user will be required to correct the interference at their own expense.

CANADA ELECTROMAGNETIC COMPATIBILITY (EMC)

Normes de sécurité (Canada)

Le présent appareil numérique n'émet pas de bruits radioélectriques dépassant les limites applicables aux appareils numériques de Classe **A** prescrites dans le règlement sur le brouillage radioélectrique édicté par le Ministère des Communications du Canada.

DOC statement (Canada)

This digital apparatus does not exceed the Class **A** limits for radio noise emissions from digital apparatus set out in the Radio Interference Regulations of the Canadian Department of Communications.

MSDS (MATERIAL SAFETY DATA SHEET)

You can obtain current Material Safety Data Sheets for the material used in the printer by visiting:
www.stratasys.com/materials/material-safety-data-sheets.

DISPOSAL OF WASTE EQUIPMENT BY USERS IN PRIVATE HOUSEHOLDS IN THE EUROPEAN UNION



This symbol on the product or on its packaging indicates that this product must not be disposed of with your other household waste. Instead, it is your responsibility to dispose of your waste equipment by handing it over to a designated collection point for the recycling of waste electrical and electronic equipment. The separate collection and recycling of your waste equipment at the time of disposal will help to conserve natural resources and ensure that it is recycled in a manner that protects human health and the environment. For more information about where you can drop off your waste equipment for recycling, please contact your local city office, your household waste disposal service or the shop where you purchased the product.

11 GLOSSARY

A | B | C | D | E | F | G | H | I | J | K | L | M | N | O | P | Q | R | S | T | U | V | W | X | Y | Z

B

Build Envelope

The area within the modeler where the part is built. The part must be small enough to fit inside the build envelope. The left side of the build envelope corresponds to the plane defined by $X = 0$. The front of the build envelope corresponds to the plane defined by $Y = 0$. The bottom of the build envelope corresponds to the plane defined by $Z = 0$. (Syn: Modeling Envelope)

Build Time

The amount of time required by the modeler to complete the part. Build time does not include the time the job waits for other jobs in the queue to complete.

C

CMB file

A file automatically created from an STL file through a process run by the Insight software. It is the CMB file that the modeler uses to create the model.

Controller Software

The internal software of the FDM System.

Current System

The modeler to which Control Center is connected - shown in the 'Name' text box and indicated by a check mark in the 'Manage Modelers...' pop up.

G

Gutter

Minimum distance between two parts in a pack. User defined. Cannot be less than Zero.

I

Insight

The software application used to prepare 3 dimensional drawings for 3 dimensional modeling. Creates CMB files from STL files.

Interactive

The ability for the program to accept user input and respond accordingly - providing information or completing a task.

J

Job

The set of data sent to a Modeler.

L

Layer

A single, horizontal, cross-sectional cut of a 3D model. The height of each layer is equal to the Layer resolution. Each slice will have support (if necessary) and model toolpath information for the modeler. (Syn: Slice)

Layer resolution

The thickness (magnitude) of each slice created by Insight. The height will be equal to the amount of material extruded to produce each layer of the model. (Syn: Slice Height)

M

Model

A customer defined physical part to be created (built) by the FDM system. (Syn: Part)

Modeler

An FDM system that builds a part. (Syn: System)

Modeling Envelope

The area within the modeler where the part is built. The part must be small enough to fit inside the modeling envelope. The left side of the modeling envelope corresponds to the plane defined by $X = 0$. The front of the modeling envelope corresponds to the plane defined by $Y = 0$. The bottom of the modeling envelope corresponds to the plane defined by $Z = 0$. (Syn: Build Envelope)

Modeling Platform

The base (platform, platen) on which models are created by the system.

O

Orientation

Refers to how the part is arranged within the modeling envelope. Orientation will impact building.

P

Pack

A collection of models that have been grouped together to facilitate building.

Part

A customer defined physical part to be created (built) by the FDM System. (Syn: Model)

Q

Queue

A lineup of models waiting to be built. When a job command is downloaded to a system, it is added as an entry to the system's queue. By default, the entry will wait until all entries submitted before it have been completed. A system administrator can edit the queue in the Queue Tab.

S

Slice

A single, horizontal, cross-sectional cut of a 3D model. Each slice will have support (if necessary) and model toolpath information for the system. See Slice Height.

Slice Height

The thickness (magnitude) of each slice created by Insight. The height will be equal to the amount of material extruded to produce each layer of the model. (Syn: Layer Resolution)

Slicing

The action of cutting the 3D STL model into a stack of 2D horizontal part boundary contours (slices). The slicing operation begins at the bottom of the model and progresses sequentially to the top at a constant interval.

STL file

A 3D drawing of your part created by a CAD software program. STL files represent the surfaces of a solid model as a mosaic of small triangles.

Support

Temporary material added during the creation of a part to prevent sag or collapse.

System

An FDM system that builds a part. (Syn: Modeler)

T

Text file

A text file is a file containing human-readable characters which are encoded in a computer-readable format called ASCII (Unix and DOS systems use ASCII; Windows 7 and Windows Vista use Unicode). Typically it has an .txt file extension. Text files are created by editors (not word processors) and do not contain special control codes to indicate formatting such as bold and underline.

Tab

A portion of the user interface that can be 'clicked' - similar to a folder tab in appearance. Tabs group user tasks by the type of operation being performed.

Tabbed Interface

An interface that uses a collection of tabs to facilitate user interaction with the Control Center application.

Toolpath

Data used to describe extrusion tip position and properties when building a part on an FDM System.

U

Unit of Measure

The definition to be used in determining the size of a part (inches or millimeters).

V

View

The 'camera angle' and 'zoom' that you choose for previewing a part. View does not impact building.

stratasys®

 goengineer

www.stratasys.com

c-support@stratasys.com

 goengineer
www.goengineer.com

3D PRINTER SALES
info@goengineer.com
855.3470.0647

CONSUMABLES HELP
supplies@goengineer.com
855.470.0647

3D PRINTER SUPPORT
AMsupport@goengineer.com
855.470.0647